

Multiband PowerTapper 150-2700 MHz

DESCRIPTION

- > 500 W power tapper with 4.8 to 30 dB coupling covering the 150 - 2700 MHz.
- > Taps off a portion of the signal from the main line.
- > Amphenol Procom tappers are symmetrical around the main line. Meaning that you will have the same good SWR from both sides of the main line.
- > Excellent high-power performance.
- > Very low insertion loss over the entire frequency range.
- > Power tappers are frequently used in distributed antenna systems in buildings or tunnels. Tappers operate similarly to directional couplers, but without the directivity (no isolation between output port and coupled port) and have relatively broad bandwidths.



ORDERING

Type	Product No.	Description
PRO-TAP 150-2700-4.8 dB-N(f)	200002374	COUPLING: 4.8 dB
PRO-TAP 150-2700-6 dB-N(f)	200002316	COUPLING: 6 dB
PRO-TAP 150-2700-8 dB-N(f)	200002448	COUPLING: 8 dB
PRO-TAP 150-2700-10 dB-N(f)	200002317	COUPLING: 10 dB
PRO-TAP 150-2700-15 dB-N(f)	200002450	COUPLING: 15 dB
PRO-TAP 150-2700-20 dB-N(f)	200002318	COUPLING: 20 dB
PRO-TAP 150-2700-30 dB-N(f)	200002456	COUPLING: 30 dB
PRO-TAP 150-2700-4.8 dB-7/16(f)	200002447	COUPLING: 4.8 dB
PRO-TAP 150-2700-6 dB-7/16(f)	200002319	COUPLING: 6 dB
PRO-TAP 150-2700-8 dB-7/16(f)	200002449	COUPLING: 8 dB
PRO-TAP 150-2700-10 dB-7/16(f)	200002320	COUPLING: 10 dB
PRO-TAP 150-2700-15 dB-7/16(f)	200002397	COUPLING: 15 dB
PRO-TAP 150-2700-20 dB-7/16(f)	200002321	COUPLING: 20 dB
PRO-TAP 150-2700-30 dB-7/16(f)	200002457	COUPLING: 30 dB
Accessories		
TB-39	200002565	

SPECIFICATIONS

Electrical							
Model	PRO-TAP 150-2700-... (dB)						
Frequency	150 - 1550 MHz and 1675 - 2700 MHz						
Coupling	4.8 dB	6 dB	8 dB	10 dB	15 dB	20 dB	30 dB
Coupling Tolerance	150 - 380 MHz: 0 / +2 dB	150 - 380 MHz: -0.5 / +2.5 dB	150 - 380 MHz: -0.5 / +2 dB	150 - 380 MHz: -0.5 / +2 dB	150 - 380 MHz: -0.5 / +1.5 dB	150 - 380 MHz: -1 / +0.5 dB	150 - 380 MHz: -3 / +1 dB
Group Delay, Coupled	< 0.8 ns						
Impedance	50 Ω						
Group Delay, Through	< 0.6 ns						
Total Loss	< 2.3 dB	< 1.9 dB	< 1.2 dB	< 0.7 dB	< 0.3 dB	< 0.2 dB	< 0.2 dB
VSWR	< 1.6:1	< 1.6:1	< 1.4:1	< 1.3:1	< 1.2:1	< 1.3:1	< 1.2:1
Max. Input Power	500 W						
Passive Intermodulation	< -150 dBc (2 x 43 dBm)						
Mechanical							
Compliance	N(f): RoHS, IP67 7/16 DIN(f): RoHS, IP67						
Connection(s)	N(f) or 7/16 DIN(f)						
Dimensions	145 x 33 x 51 mm / 5.71 x 1.30 x 2.01 in.						
Weight	Approx. 0.55 kg / 1.21 lb						
Mounting	6.5 mm dia (two holes)						
Environmental							
Operating Temperature Range	-30°C to +60°C						

MOUNTING DETAILS STANDARD BRACKET

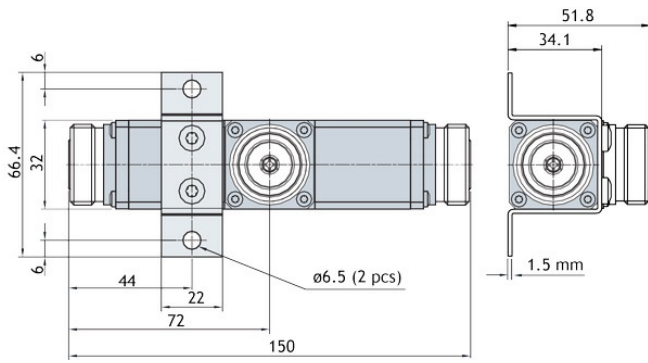

MOUNTING DETAILS STANDARD BRACKET

Side Mounting

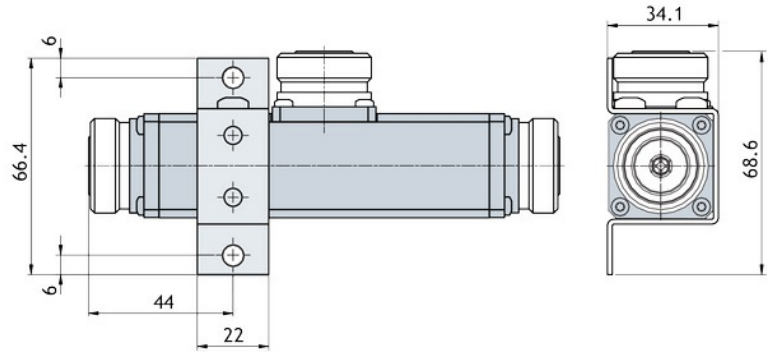

ACCESSORIES: TB-39 BRACKET

Extra High

