

- Precision phase adjustable adapters, DC to 50.0 GHz.
- Impedance of 50 Ohms is maintained over the full adjustment range.
- Positive resettable locking mechanism.
- Smooth continuous phase adjustment.
- Physical length change of the unit equals the electrical length change.
- Rugged construction, housing and outer conductors are made from stainless steel.
- Besides the Standard Units, High Precision Components are offered, showing superior electrical performance to 50.0 GHz, being easily identified by their gold plated body.

- Bead captivated center contacts.
- Spring fingers and center contacts are made from beryllium copper, heat treated and gold plated per AST-B-488; Type III, Code C
- 2.4 mm connector interface specification per MIL-STD-348A.
- Operating temperature range: -54°C to +85°C.
- Mounting Brackets are optional and are shown on the drawings below and to the right.

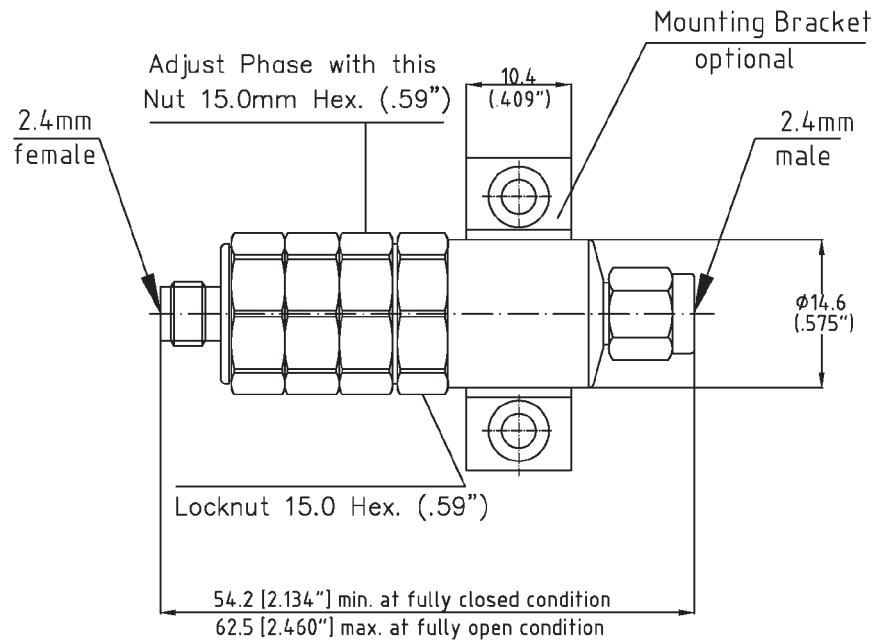

Part Number	Frequency Range	VSWR max.	Insertion Loss max.	Phase Shift min.	No. of Turns	Nom. Phase Shift Deg./GHz/ Turn	Time Delay (psec.) min. max.	Weight max.
LS-0150-HFHF LS-P150-HFHF	DC - 50.0 GHz	1.50:1	0.8 dB	450° at 50.0 GHz	8	1.2	172 195	53 g
LS-0150-HFHM LS-P150-HFHM		1.30:1						55 g

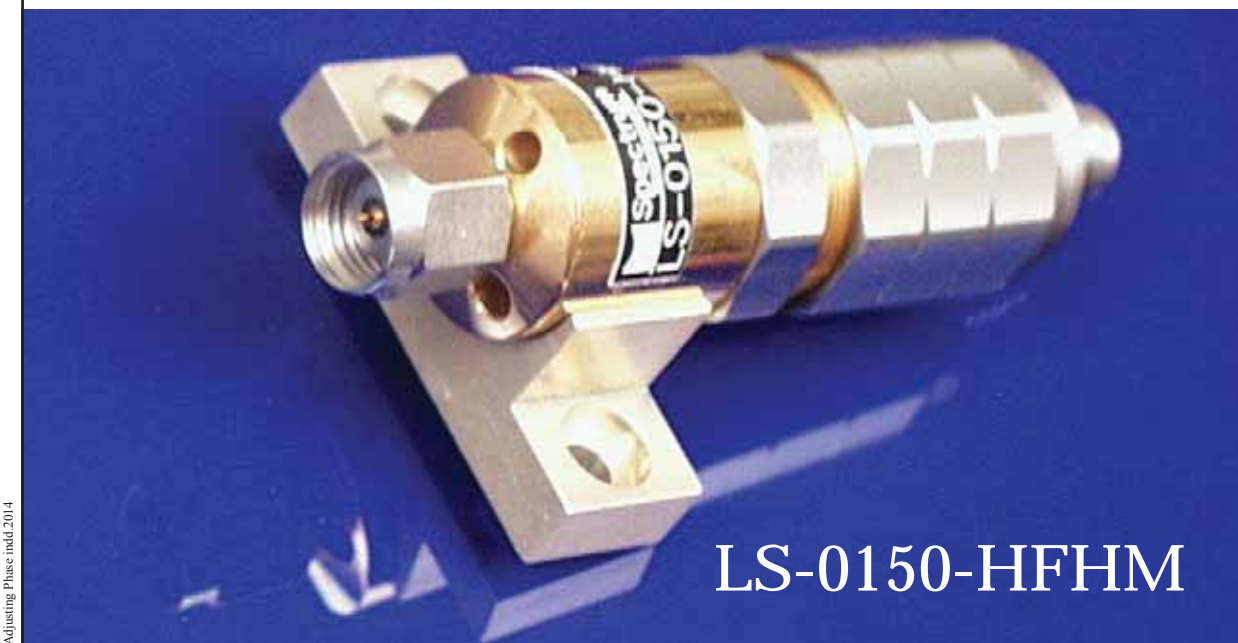
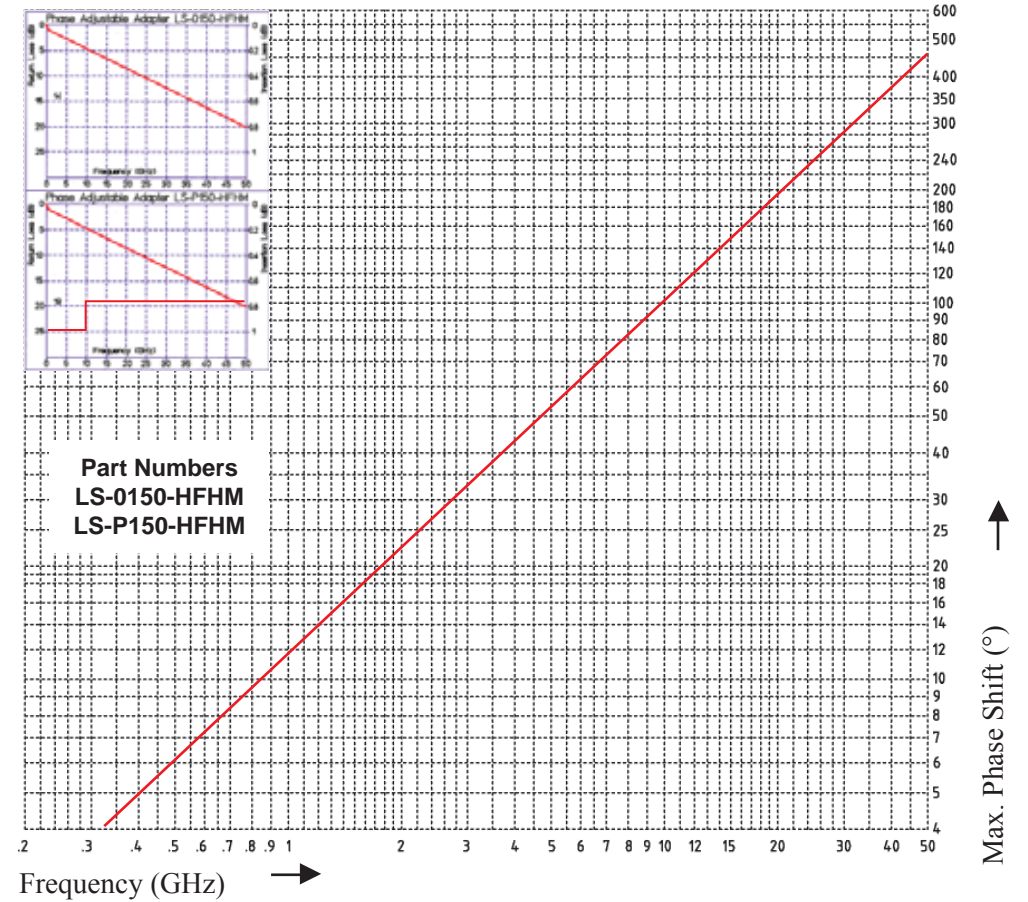

Adjusting Phase.indd.2014