

## Universal, 0 dBd Base Station and Marine Antenna for the 1090 MHz Band

### DESCRIPTION

- CXL 1090-1LW is a 0 dBd, vertically polarized, omnidirectional base station and marine antenna, which covers the 1090 MHz band.
- Provided with the sturdy "LW" mast mount – a lightweight, multipurpose, epoxy-coated mounting bracket made of non-corrosive aluminium.
- Especially designed for ADS-B aerial surveillance.
- The accompanying U-bolts and fittings are made of stainless steel.
- To be mounted on vertical or horizontal mast tubes, 16 to 54 mm in outer diameter.
- The cable can be led either on the outside or along the inside of the mast tube.
- Large bandwidth with respect to both VSWR and gain.
- The carefully designed, broad-banded antenna element is sealed in a high-quality, conical glass fibre tube with low wind-load, which will ensure performance undisturbed by corrosive environments.
- To substantially reduce noise caused by atmospherical discharges, all metal parts in the antenna are DC-grounded. Consequently, the antenna shows a DC-short across the coaxial cable.
- The CXL 1090-1LW is a vibration-proof, lightweight, slim-line, corrosion resistant, modern style base station and marine antenna.



### SPECIFICATIONS

Electrical	
Model	CXL 1090-1LW
Frequency	1050 - 1130 MHz
Antenna Type	Coaxial dipole, broad-banded
Max. Input Power	100 W
Polarisation	Vertical
Pattern Type	Omnidirectional
3 dB Beamwidth, E-Plane	80 °
3 dB Beamwidth, H-Plane	Omnidirectional
Impedance	50 Ω
Gain	0 dBd (2.2 dBi)
VSWR	< 1.5:1
Bandwidth	80 MHz
Antistatic Protection	All metal parts DC-grounded (Connector shows a DC-short)
HCM Code(s)	HCM000ND00, 040DE00

Mechanical	
Connection(s)	N(f)
Materials	Shroud: Polyurethane-coated glass fibre Mounting bracket: Seawater resistant aluminium, epoxy-coated Clamps: Stainless steel
Colour	White (RAL 9003)
Wind Area	0.018 sq. m / 0.19 sq. ft.
Wind Load	23 N (160km/h)
Dia. At Top End	13 mm / 0.51 in.
Dia. At Bottom End	16 mm / 0.63 in.
Height	490 mm / 19.29 in.
Weight	0.56 kg / 1.23 lb
Mounting	On 16 to 54 mm dia. mast tube

Environmental	
Operating Temperature Range	-30°C to +70°C
Survival Wind Speed	200 km/h
Ingress Protection	IP66

### ORDERING

Model	Product No.	Frequency
CXL 1090-1LW	100000637	1050 - 1130 MHz

### MULTI-PURPOSE MOUNTING BRACKET

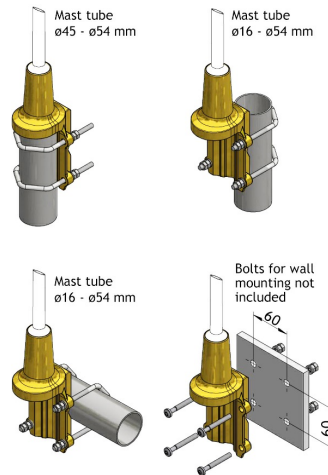

### PLEASE NOTE

The antenna is delivered with a DC-connection between the antenna element and the mounting bracket.

TYPICAL RADIATION PATTERN (E-PLANE)

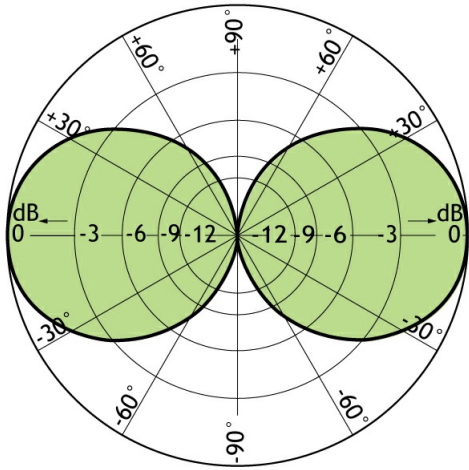

TYPICAL RADIATION PATTERN (H-PLANE)

