

SP3T to SP6T Electromechanical Switch

Normally Open, DC to 40 GHz, 2.92mm, TTL, 15 Pin D-Sub

Electrical

Switch Type	SPnT, Reflective			
Actuator Type	Normally Open			
Switching Sequence	Break before make			
Switching Time	15 ms max			
Impedance	50 Ohms			
Frequency Range	DC-40 GHz			
*Nominal Actuating Voltage, Vdc	12 (11 to 13)	18 (16 to 20)	24 (22 to 26)	28 (26 to 30)
Actuating Current, mA	290	190	150	140
TTL Control	On: 2.4 to 5 Volts, Off: 0 to 0.8 Volts			



Frequency (GHz)	DC-6	6-12	12-18	18-26.5	26.5-40
VSWR (max)	1.3	1.4	1.5	1.9	2.0
Insertion Loss dB (max)	0.30	0.40	0.50	0.80	1.00
Isolation dB (min)	70	60	60	50	50

Environmental & Mechanical

Operating Temperature	-25°C~+65°C
Storage Temperature	-55°C~+85°C
Shock (Designed to meet)	MIL-STD-202 Method 213, Condition D, 500G (Non Operating)
Vibration (Designed to meet)	MIL-STD-202 Method 214, Condition D, 10G RMS (Non Operating)
Operating Life	2 Million Cycles Minimum
RF Connector	2.92mm Female
Actuator Terminals	15 Pin D-Sub Male
Weight	285g max

Notes

*For model RSn-K40NXX-TD, replace the XX with the desired Actuator Voltage. Example: RSn-K40N12-TD for 12 Volts.

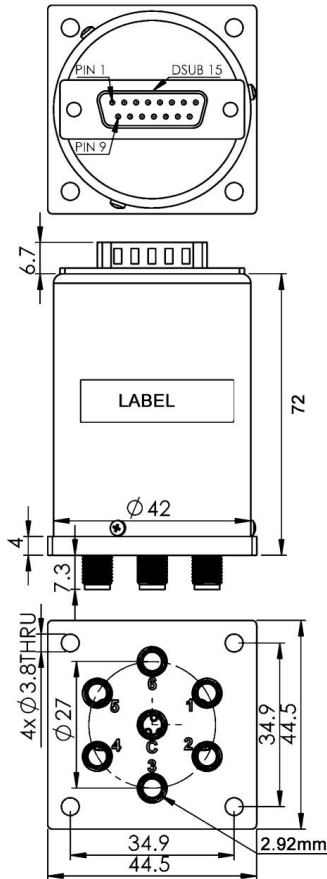
SP3T to SP6T Electromechanical Switch
Normally Open, DC to 40 GHz, 2.92mm, TTL, 15 Pin D-Sub
Drawing (unit: mm, tolerance +/-0.5mm)

15 Pin D-Sub

Pin No.	Define	Pin No.	Define
1	TTL INPUT 1	9	N/A
2	TTL INPUT 2	10	N/A
3	TTL INPUT 3	11	N/A
4	TTL INPUT 4	12	N/A
5	TTL INPUT 5	13	N/A
6	TTL INPUT 6	14	N/A
7	-COM	15	+VDC
8	N/A		

SPnT RF Ports Configurations

SPnT	Ports Used					
SP6T	1	2	3	4	5	6
SP5T	1	2	3	4	5	
SP4T	1	2		4	5	
SP3T	1		3		5	

Schematic
