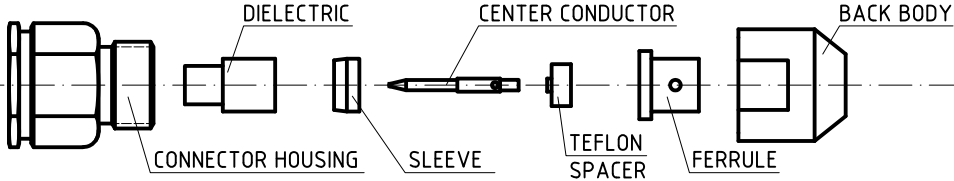
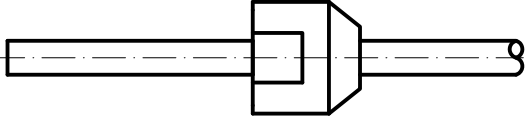
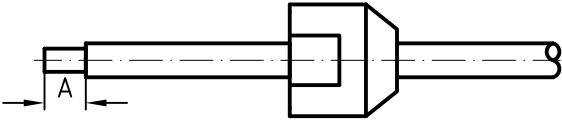
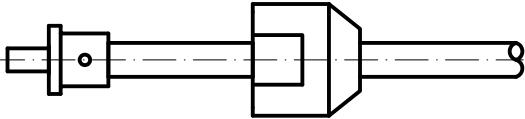
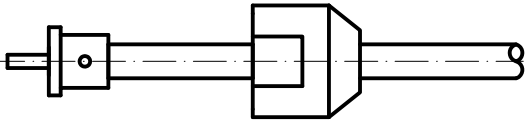
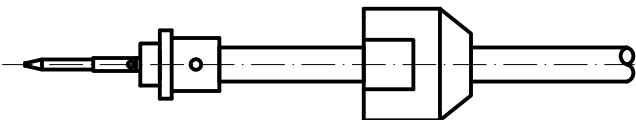
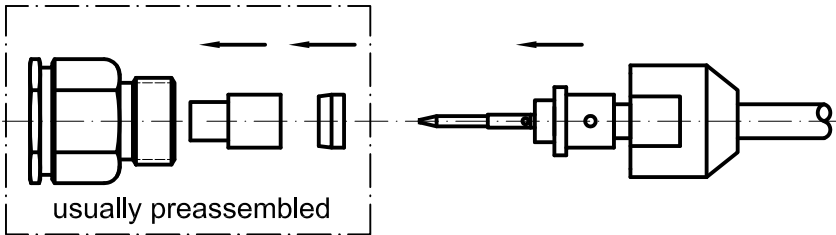

Bearb.		TPU	
CONNECTOR TYPE	CABLE TYPE	CONNECTOR COMPONENTS	TOOLS REQUIRED
N-Male metric	S/R .141"		
PROCEDURE			
1	Slide back body over cable.		
PROCEDURE			
2	Trim outer conductor and dielectric to following dimensions: A = 4.2 mm (.165")		
PROCEDURE			
3	Slide ferrule over outer conductor, seat firmly and solder.		
PROCEDURE			
4	Trim dielectric. It should be flush with the ferrule.		
PROCEDURE			
5	Slide teflon spacer and center conductor of connector over center conductor of cable, seat firmly and solder.		
PROCEDURE			
6	Insert dielectric and sleeve into connector housing. Insert cable assembly into connector housing. Engage threads of back body and connector housing and torque to 38 inch pounds (4.3 Nm).	 <p>usually preassembled</p>	