

## 50 W Diplexer for the 0 - 270 MHz and 300 - 512 MHz Ranges

### DESCRIPTION

- > Diplexer for combining or splitting the two ranges 0 – 270 MHz and 300 – 512 MHz.
- > Elliptical filter design.
- > Diplexer for combining or splitting the two ranges 0 – 270 MHz and 300 – 512 MHz.
- > Elliptical filter design.
- > Low insertion loss in spite of very narrow guard band.
- > High power handling capability.
- > High isolation.
- > Low weight.
- > Wide temperature range.
- > Milled aluminium box ensures extraordinarily high mechanical strength.
- > PRO-DIPX 270/300-... is coated with black vinyl to prevent corrosion.
- > N-connectors on all ports (standard).
- > Also available with SMA-, TNC- or BNC- connector types.



### ORDERING

Model	Product No.
PRO-DIPX 270/300-N	200002274
PRO-DIPX 270/300-SMA	200002225
PRO-DIPX 270/300-TNC	200002275
PRO-DIPX 270/300-BNC	200002276

### SPECIFICATIONS

Electrical	
Model	PRO-DIPX 270/300-...
Frequency	COM-LOW port: 0 - 270 MHz COM-HIGH port: 300 - 512 MHz
Max. Input Power	50W CW simultaneously on both HIGH and LOW port
Insertion Loss	0 - 270 MHz: = 0.7 dB 300 - 512 MHz: = 0.7 dB
Impedance	50 Ω
Isolation	LOW to HIGH port: = 40 dB
VSWR	< 1.5:1

Mechanical	
Connection(s)	INPUT: N-female OUTPUT: N-female (Other types available on request)
Dimensions	103 x 80 x 31 mm / 4.06 x 3.15 x 1.22" (incl. connectors and flanges)
Weight	0.27 kg / 0.60 lb
Mounting	4.3mm dia. (4 holes)

Environmental	
Operating Temperature Range	-40°C to +60°C
Ingress Protection	IP64

ADDITIONAL DATA

TYPICAL RESPONSE CURVES

INSERTION LOSS [dB]

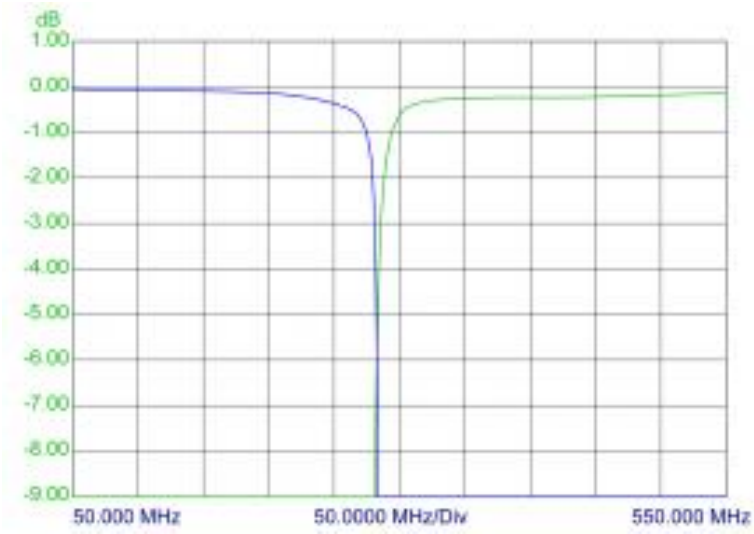

PORT ATTENUATION [dB]

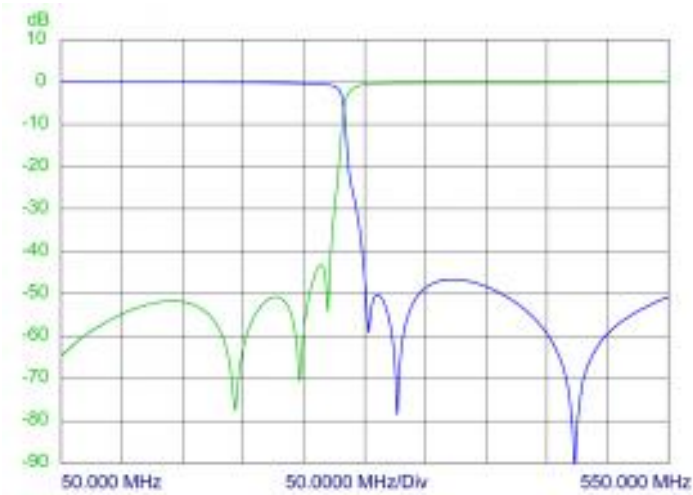

MOUNTING DETAILS

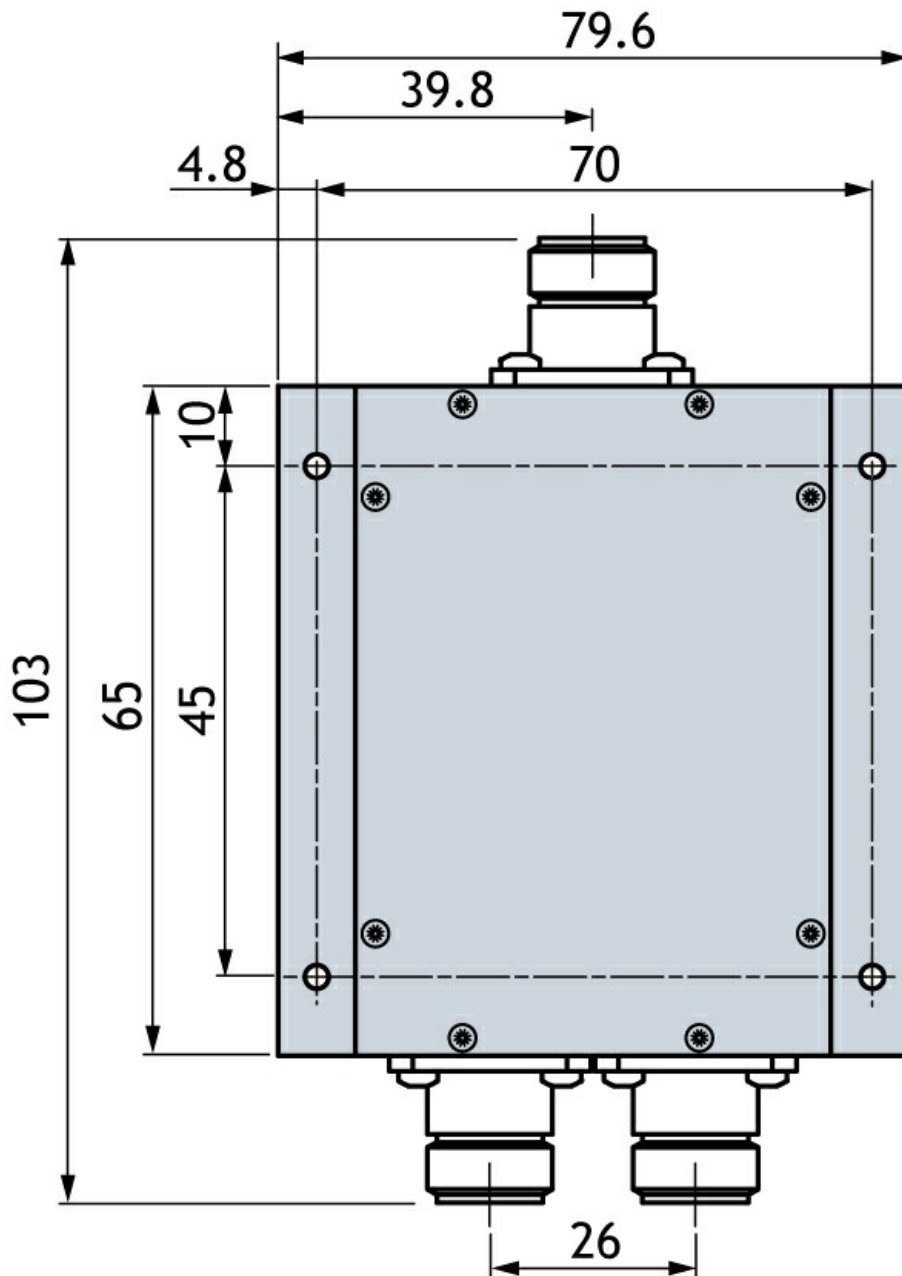

The PRO-DIPX 270/300-... makes it possible to use only one antenna for the operation of two transceivers (one in each range). See the figure below. The antenna must be a dual-frequency antenna, i.e. it must be resonant on the actual frequencies in the two bands.

The transceivers may be used independently and will have no degrading influence on each other. Typically, the diplexer is installed next to the transceivers and only one cable is used between the diplexer and the antenna. The diplexer is suitable both for base station and mobile use.

The main tasks of the diplexer are to protect the individual receiver input from being destroyed by the transceiver in the contrary band and to ensure a low-loss path between the transceiver and the antenna which is not loaded by the other branch.

The diplexer can be operated together with any set of transceivers operating within the 0 - 270 MHz and 300 - 512 MHz frequency bands.

