

100 W Diplexer for the 0 - 130 MHz and 150 - 960 MHz Ranges

DESCRIPTION

- > Diplexer for combining or splitting the two ranges 0 – 130 MHz and 150 – 960 MHz.
- > Chebychev design ensures very high isolation across the whole pass ranges.
- > High power handling capability.
- > Low insertion loss.
- > Low weight.
- > Wide temperature range.
- > Milled aluminium box ensures extraordinarily high mechanical strength.
- > PRO-DIPX 130/150-... is coated with black vinyl to prevent corrosion.
- > N-connectors on all ports (standard).
- > Also available with SMA-, TNC- or BNC- connector types.



ORDERING

Model	Product No.
PRO-DIPX 130/150-N	200002227
PRO-DIPX 130/150-SMA	200002224
PRO-DIPX 130/150-TNC	200002257
PRO-DIPX 130/150-BNC	200002258

SPECIFICATIONS

Electrical	
Model	PRO-DIPX 130/150-"
Frequency	COM-LOW port: 0 - 130 MHz COM-HIGH port: 150 - 960 MHz
Max. Input Power	100W CW simultaneously on both HIGH and LOW port
Insertion Loss	0 - 130 MHz: = 0.7 dB 150 - 960 MHz: = 0.7 dB
Impedance	50 Ω
Isolation	LOW to HIGH port: = 40 dB
VSWR	< 1.5:1
Mechanical	
Connection(s)	INPUT: N-female OUTPUT: N-female (Other types available on request)
Dimensions	133 x 80 x 31 mm / 5.24 x 3.15 / 1.22" (incl. connectors and flanges)
Weight	0.38 kg / 0.84 lb
Mounting	4.3mm dia. (4 holes)
Environmental	
Operating Temperature Range	-40°C to +60°C
Ingress Protection	IP64

ADDITIONAL DATA

TYPICAL RESPONSE CURVES

INSERTION LOSS [dB]

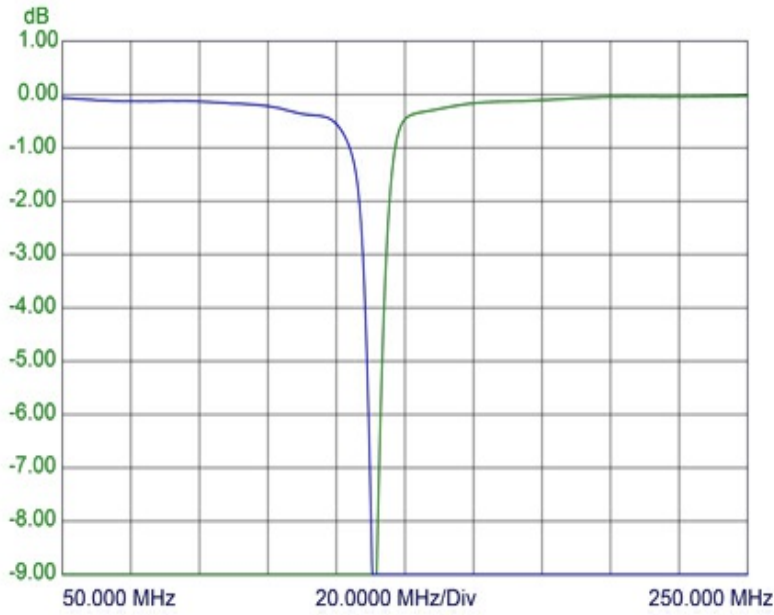

PORT ATTENUATION [dB]

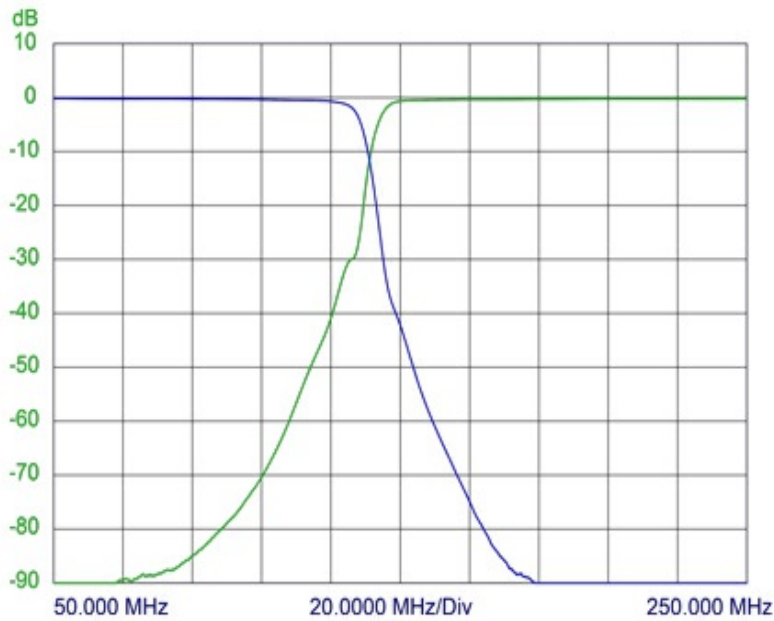

MOUNTING DETAILS

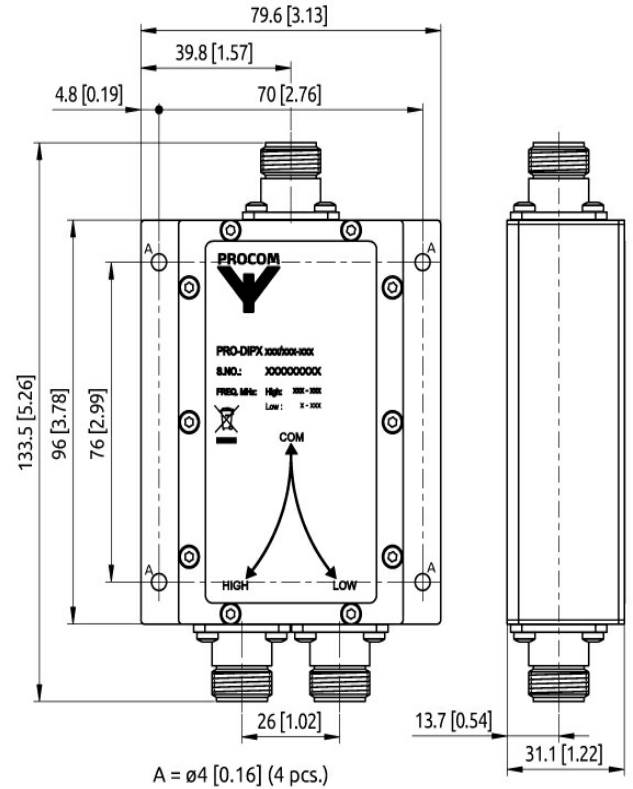

A = $\varnothing 4$ [0.16] (4 pcs.)

All dimensions are given in mm [in.]

INSTALLATION

The PRO-DIPX 130/150-... makes it possible to use only one antenna for the operation of two transceivers (one in each range). See the figure below. The antenna must be a dual-frequency antenna, i.e. it must be resonant on the actual frequencies in the two bands.

The transceivers may be used independently and will have no degrading influence on each other. Typically, the diplexer is installed next to the transceivers and only one cable is used between the diplexer and the antenna. The diplexer is suitable both for base station and mobile use.

The main tasks of the diplexer are to protect the individual receiver input from being destroyed by the transceiver in the contrary band and to ensure a low-loss path between the transceiver

and the antenna which is not loaded by the other branch.

The diplexer can be operated together with any set of transceivers operating within the 0 - 130 MHz and 150 - 960 MHz frequency bands.

