

450 MHz 2 dB mobile antenna for glass fibre roof

DESCRIPTION

- Ground plane independent antenna for installation on non-conducting surfaces.
- Ideal for glass fibre roofs as can be found on some trucks, busses, transport vans and trains.
- MU 9-XP4/s can be tuned by cutting within 380...410 MHz.
 MU 9-XP4/l can be tuned by cutting within 400...440 MHz.
 MU 9-XP4/h can be tuned by cutting within 430...470 MHz.
- M6-thread whip-fastening system.
- Simple mounting exclusively with access from the outside.
- Models available with oblong or circular mount.
- Also oblong models with GPS are available.
- Delivered with permanently attached 4 m RG 58 cable terminated with FME-connector.
 (Other models on request)
- ECE R118.02 approved cable.



SPECIFICATIONS

Electrical	
Model	MU 9-XP4/..., MU 9-CXP4/..., MU 9-XGP4/...
Frequency	450 MHz band covered by three models
Antenna Type	End-fed 1/2λ dipole mobile antenna
Max. Input Power	40 W
Polarisation	Vertical
Impedance	50 Ω
Gain (EIA RS-329-1)	2 dB
Mechanical	
Compliance	ECE R118.02 approved cable
Connection(s)	Cable RG 178, length 150 mm Connector: FME-male
Materials	Whip : Polyethylene-covered spring steel wire Mount : Black-chromed brass Weather- and shockproof plastics Surface treated steel
Cable	4 m cable terminated with FME-connector. (Other cable lengths on request)
Installation Torque	Max. 3 Nm
Colour	Black
Height	Approx. 410 mm / 16.14 in.
Weight	Approx. 0.21 kg / 0.46 lb.
Mounting	From outside : 21 mm dia. hole From inside : 14 mm dia. hole
Mounting For GPS-Models	19 mm dia. hole
Mounting Plate Thickness	0.6 - 5 mm / 0.02 - 0.20 in.
GPS Antenna	
Noise Figure (GPS Amplifier)	Max.1.5 dB (typical 1.1 dB)
Gain (GPS Amplifier)	22 dB ±2 dB
Frequency (GPS)	1575.42 ±1.023 MHz
Power Supply (GPS)	DC 2.85 V ~ 5 V (typical 3 V)
Impedance (GPS)	50 Ω

ORDERING

Model	Product No.	Description	Frequency
MU 9-XP4/s	130001089	Oblong mount with 4 m cable and FME-conn.	380... 410 MHz
MU 9-XP4/l	130001097	Same mount as above	400... 440 MHz
MU 9-XP4/h	130001085	Same mount as above	430... 470 MHz
MU 9-CXP4/s	130001096	Circular mount with 4 m cable and FME-conn.	380... 410 MHz
MU 9-CXP4/l	130001098	Same mount as above	400... 440 MHz
MU 9-CXP4/h	130001086	Same mount as above	430... 470 MHz
MU 9-XGP4/s	132000190	Oblong mount with 4 m and FME-conn., and GPS	380... 410 MHz
MU 9-XGP4/l	132000189	Same mount as above	400... 440 MHz
MU 9-XGP4/h	132000188	Same mount as above	430... 470 MHz

ORDERING DESIGNATIONS

TYPE	PRODUCT NO.	CELLULAR SYSTEM	MOUNT VERSION
READY-TUNED MODELS (examples)			
MU 9-XP4/380-410 MHz	Contact for availability	TETRA BOS, Germany	Oblong mount with 4 m cable and FME-conn.
MU 9-XP4/410-430 MHz	Contact for availability	Industrial Systems Germany	Same mount as above
MU 9-XP0.1/380-410 MHz-MFME	Contact for availability	TETRA BOS, Germany	Oblong mount with 0.1 m cable and FME-male conn.
MU 9-CXP4/380-410 MHz	Contact for availability	TETRA BOS, Germany	Circular mount with 4 m cable and FME-conn.
MU 9-CXP4/410-430 MHz	Contact for availability	Industrial Systems Germany	Same mount as above
MU 9-CXP0.1/ 380-410 MHz-MFME	Contact for availability	TETRA BOS, Germany	Circular mount with 0.1 m cable and FME-male conn.
MU 9-XGP4/380-410 MHz	Contact for availability	TETRA BOS, Germany	Oblong mount with 4 m cable and FME-conn., and GPS
MU 9-XGP0.1/ 380-410 MHz-MFME	132000191	TETRA BOS, Germany	Oblong mount with 0.1 m cable and FME-male conn., and GPS

When ordering a ready-tuned model, the name of the desired cellular system must be added to the antenna model number.

INSTALLATION

This antenna is especially designed for installation on non-conducting surfaces as e.g. glass fibre roofs, as can be found on some trucks, busses, transport vans and trains.

The antenna is an end-fed, 1/2 λ-dipole concept which can be fed in such a way that the antenna does not require a "ground plane" as required by the standard 1/4 λ, 5/8 λ or collinear mobile whips.

It is useful to note that this antenna type can be used anywhere where the ground plane is poor or completely missing, as e.g.: side-mounted on a clamp as a pager antenna on a wall or mounted at the very edge of a ground-plane without the loss induced by a tilted radiation pattern.

The antenna must be mounted on a horizontal surface. When cleaning the vehicle in car-washing machines, the whip is easily dismounted using a spanner, size 9 mm. The whip is refitted again by screwing it onto the M6 thread stud on the mount and tightening it lightly with the spanner.

A polyethylene-covered, closely spirally wound flat steel-band material causes the whip always to stand erect while at the same time being very flexible.

1. INSTALLATION DIMENSIONS

1A.

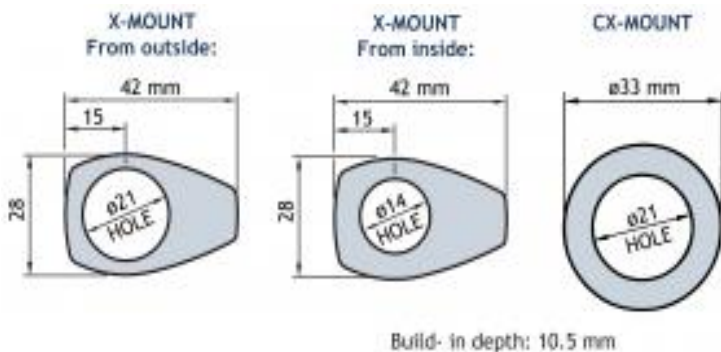

1B. FOR GPS-MODELS

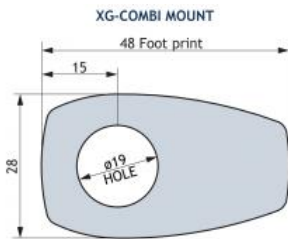

2. INSTALLATION STEPS

2A. (FROM OUTSIDE)

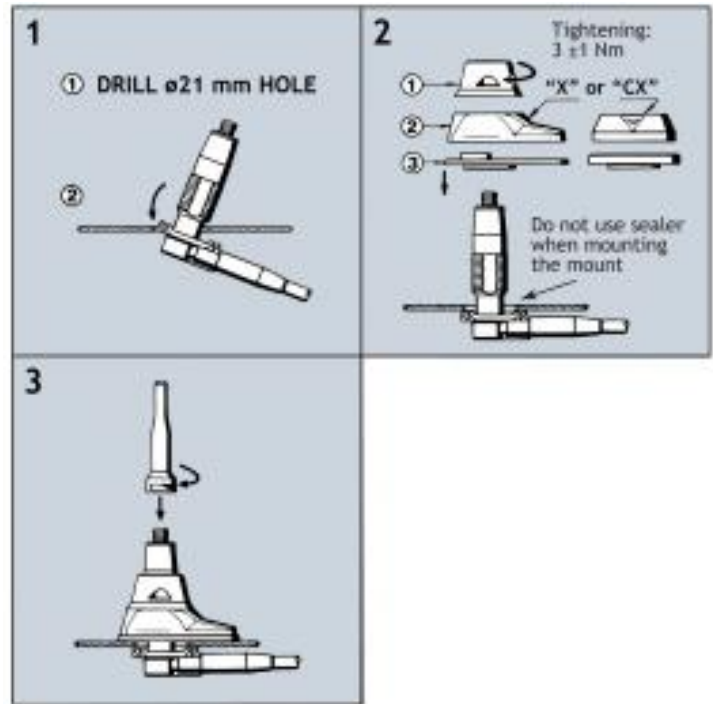

Do not use sealer on rubber gasket or other places.

2B. FOR GPS-MODELS (FROM OUTSIDE)

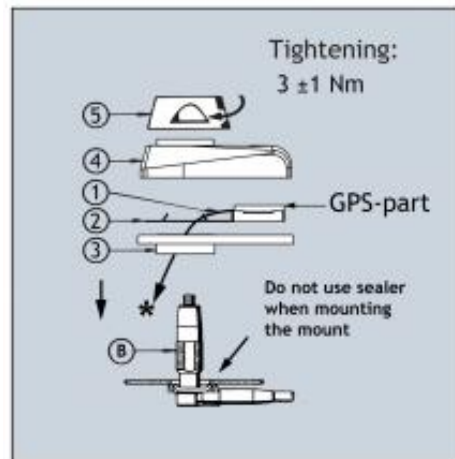

Do not use sealer on rubber gasket or other places.

2B. ASSEMBLY INSTRUCTIONS (FOR GPS-MODELS)

- Put GPS-FME-connector-cable through the gasket (2).
- Put the gasket (3) + GPS-part (1) over the body (B).
- Put the body (B) + gasket (3) + GPS-part (1) through the ø19 mm hole.
- Put the housing (4) over the body (B) and be sure that the GPS-part (1) fits into the square hole in the body (B).
- Put the threaded part over the body (5) and tighten max. 3 ± 1 Nm!
- Mount the antenna whip.

3. TUNING

The antenna should always be tuned using an SWR-indicating device. The cutting diagrams below serve as a guide for this procedure.

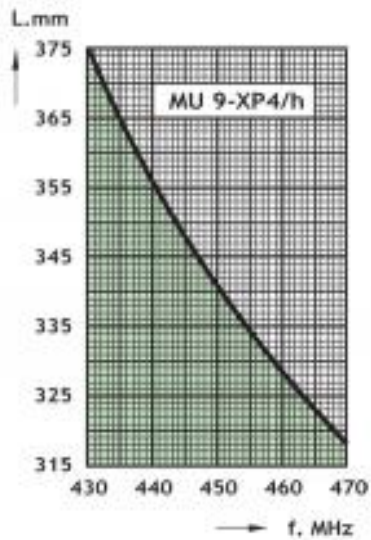
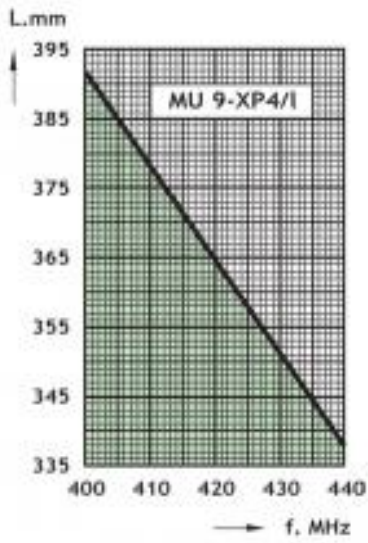
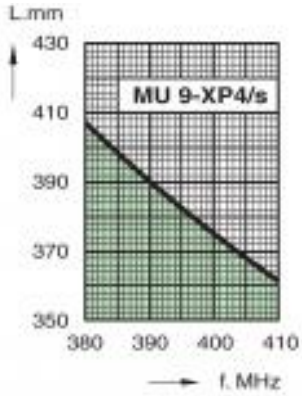

MU 9-XGP4 MOUNT



Please note that the MU 9-XP4, MU 9-CXP4 and MU 9-XGP4 type "s", "l" and "h" mounts contain matching transformers. Consequently, these special mounts cannot operate with other whip types.

