

colinear 4 dB Mobile Antenna for the 450 MHz Band

DESCRIPTION

- > 4 dB mobile antenna series with colinear, stainless steel whip with toggle joint.
- > Models with Z-mount or MG-magnetic mount.
- > Choice between Z-mount with FME-connection (supplied without cable) or ZP4-mount with factory fitted 4 m cable terminated with FME-connector.
- > MG-models provided with FME-connection directly on the mount (without cable).
- > Z-type models available in bright or black chromed versions. MG-models available in bright polished only.



SPECIFICATIONS

Electrical	
Model	MU 4-Z/...
Frequency	Models within 380 - 470 MHz
Antenna Type	Collinear stainless steel mobile whip antenna
Max. Input Power	100 W
Polarisation	Vertical
Impedance	50 Ω
VSWR	≤ 1.3 @ f. res.
Bandwidth	> 15 MHz @ VSWR < 1.5 > 30 MHz @ VSWR < 2.5
Gain (EIA RS-329-1)	4 dB
Mechanical	
Materials	Whip: Stainless steel and brass, bright polished/chromed or black-chromed Mount: Chromed brass (bright or black) Weather- and shockproof plastics Stainless steel
Installation Torque	7.5 ±1 Nm
Colour	Bright or black (see above)
Height	Approx. 590 mm / 23.23 in. (dep. on freq.)
Weight	Z-version : Approx. 230 g / 0.51 lb. ZP4-version : Approx. 370 g / 0.82 lb. MG-version : Approx. 930 g / 2.05 lb.
Mounting	21mm dia. hole (For roof thicknesses 2 mm up to 7.5 mm mounting hole should be 22mm dia.)
Mounting Plate Thickness	Max. 2.0 mm (Models up to 7.5 mm on request)

ORDERING

Model	Product No.	Description	Frequency
MU 4-MG/s	130000902		380...410 MHz
MU 4-MG/f	130000903		406...430 MHz
MU 4-MG/h	130000904		440...470 MHz
MU 4-MG/l	130000905		420...450 MHz
MU 4-MG/CEL3	130000906		425 - 440 MHz
MU 4-MG/CEL1	130000906		450 - 470 MHz
MU 4-MG/CEL4	130000955		414 - 430 MHz
MU 4-BZ/f	130001001	BZ-mount with FME BLACK	406...430 MHz
MU 4-BZP4/f	130000977	BZP4-mount with 4 m cable BLACK	406...430 MHz
MU 4-BZ/h	130001004	BZ-mount with FME BLACK	440...470 MHz
MU 4-BZP4/h	130000987	BZP4-mount with 4 m cable BLACK	440...470 MHz
MU 4-BZ/l	130000997	BZ-mount with FME BLACK	420...450 MHz
MU 4-BZP4/l	130000993	BZP4-mount with 4 m cable BLACK	420...450 MHz
MU 4-BZ/CEL4	130001010	BZ-mount with FME BLACK	414 - 430 MHz
MU 4-BZ/CEL1	130001000	BZ-mount with FME BLACK	450 - 470 MHz
MU 4-BZP4/ CEL1	130000988	BZP4-mount with 4 m cable BLACK	450 - 470 MHz
MU 4-BZP4/ CEL4	130000989	BZP4-mount with 4 m cable BLACK	414 - 430 MHz
MU 4-BZP4/ CEL3	130000991	BZP4-mount with 4 m cable BLACK	425 - 440 MHz
MU 4-BZP4/ CEL2	130000996	BZP4-mount with 4 m cable BLACK	440 - 455 MHz
MU 4-BZ/s	130000999	BZ-mount with FME BLACK	380...410 MHz
MU 4-BZP4/s	130000976	BZP4-mount with 4 m cable BLACK	380...410 MHz
MU 4-Z/f	130000975	Z-mount with FME BRIGHT	406...430 MHz
MU 4-ZP4/f	130000978	ZP4-mount with 4 m cable BRIGHT	406...430 MHz
MU 4-Z/h	130000983	Z-mountwith FMEBRIGHT	440...470 MHz
MU 4-ZP4/h	130000986	ZP4-mountwith 4 m cableBRIGHT	440...470 MHz
MU 4-Z/l	130000992	Z-mount with FME BRIGHT	420...450 MHz
MU 4-ZP4/l	130000994	ZP4-mountwith 4 m cableBRIGHT	420...450 MHz
MU 4-Z/CEL4	130001002	Z-mount with FME BRIGHT	414 - 430 MHz
MU 4-Z/CEL1	130001003	Z-mount with FME BRIGHT	450 - 470 MHz
MU 4-ZP4/ CEL1	130001006	ZP4-mount with 4 m cable BRIGHT	450 - 470 MHz
MU 4-ZP4/ CEL4	130001007	ZP4-mount with 4 m cable BRIGHT	414 - 430 MHz
MU 4-ZP4/ CEL3	130001009	ZP4-mountwith 4 m cableBRIGHT	425 - 440 MHz
MU 4-ZP4/ CEL2	130001012	ZP4-mountwith 4 m cableBRIGHT	440 - 455 MHz
MU 4-Z/s	130001015	Z-mountwith FMEBRIGHT	380...410 MHz
MU 4-ZP4/s	130001016	ZP4-mount with 4 m cable BRIGHT	380...410 MHz
MU 4-MG/CEL2	130001328		440 - 455 MHz
MU 4-BZ/CEL2	130001011	BZ-mount with FME BLACK	440 - 455 MHz
MU 4-BZ/CEL3	130001005	BZ-mount with FME BLACK	425 - 440 MHz
MU 4-Z/CEL2	130001466	Z-mount with FME BRIGHT	440 - 455 MHz
MU 4-Z/CEL3	130001467	Z-mount with FME BRIGHT	425 - 440 MHz

THE WHIP IS COMPATIBLE WITH ALL BELOW MOUNTS

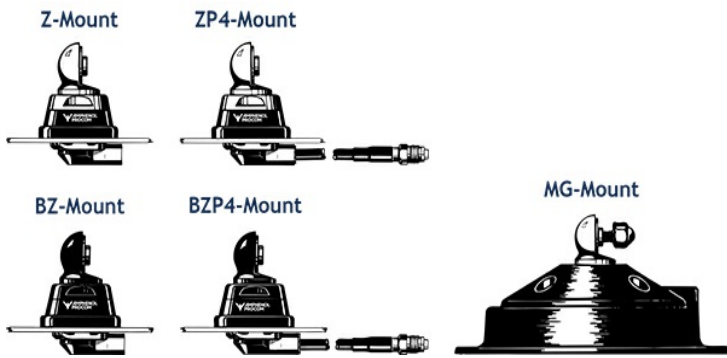

Whips from the Z/ZP4 mounts and the MG-mount are **NOT** compatible.

Hat screw option:

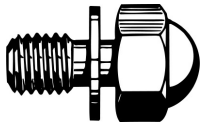

(Z-/ZP4-type models only): For antenna delivered with hat screw instead of wing screw add a K to the antenna designation.

INSTALLATION

The antenna whip comprises a $\frac{1}{4} \lambda$ section, a phase shifting coil, and a $\frac{1}{2} \lambda$ section. The whip is fastened to the mount by means of our standard ball joint and wing screw system. The adjustable ball joint ensures that the whip can always be mounted in a vertical position independent of the angle of the installation spot.

The Z-mount is particularly well suited for mounting on car roofs because of its ability to be installed exclusively with access from the outside. The Z-Mount for roof thickness from 2 mm to 7.5 mm must be mounted from the inside.

However, the antenna can be installed anywhere on the car, as the Z-mount is equally well suited for mounting on e.g. trunk or wing.

The "MG"-mount antennas are provided with a large-diameter, thoroughly magnetized permanent ring magnet with an extraordinarily high attaching effect. A silicone layer applied to the whole contact surface protects the car roof and ensures maximum friction.

Please note that the whips from the Z/ZP4-mounts and the whips from the MG-mount are not compatible.

1. INSTALLATION DIMENSION

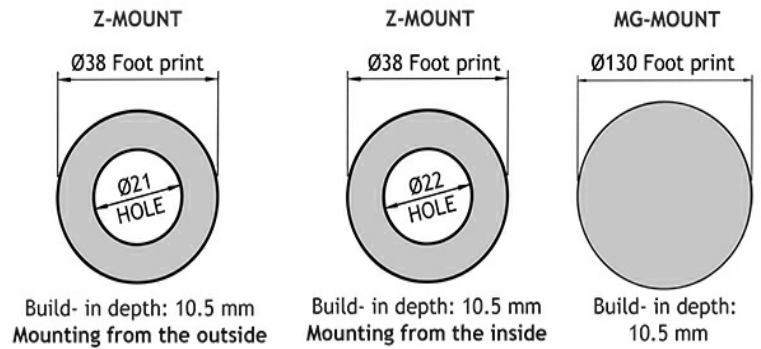

2. INSTALLATION STEPS

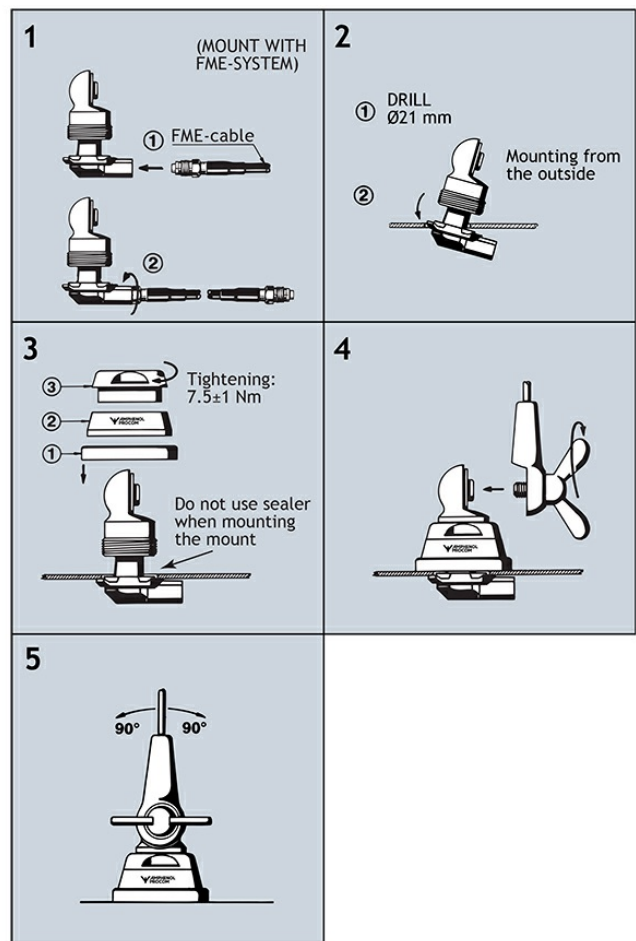

Do not use sealer on rubber gasket or other places.

3A. TUNING

The antenna is delivered factory-tuned and requires no further tuning.

Z- and ZP4-models

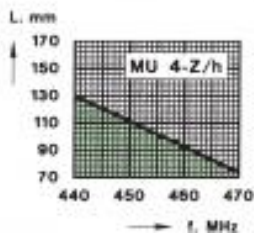
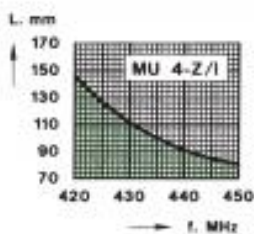
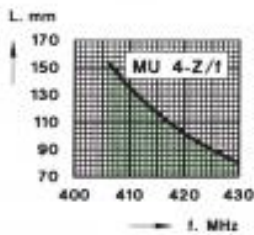
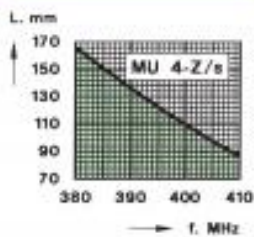

3B. TUNING

MG-models

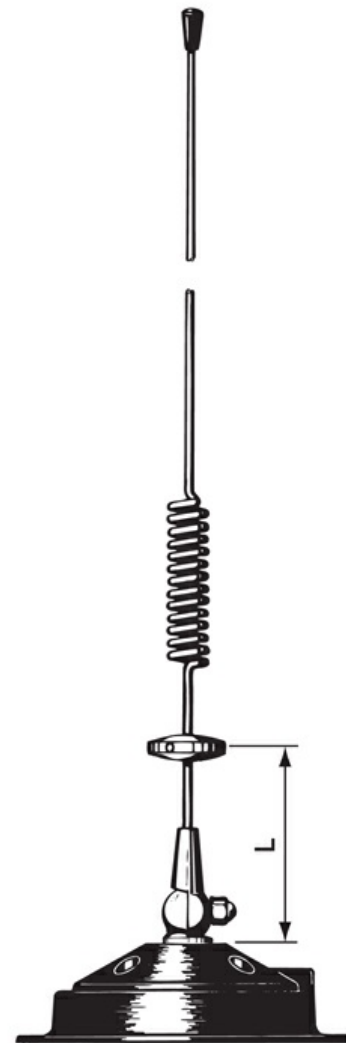
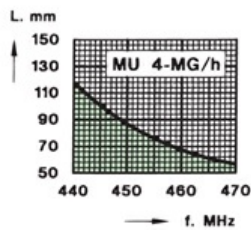
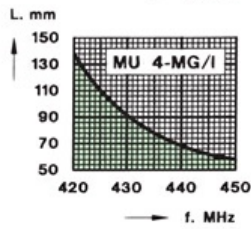
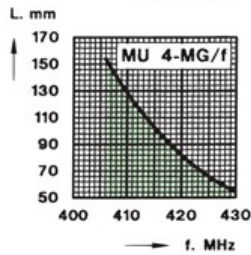
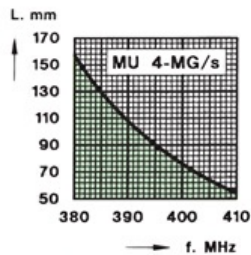

PLEASE NOTE

For safety reasons:
When using the MU 4-MG/..., car speed must not exceed 140 km/h.