

FLSH-FLSH-D101-02_100-P

Description

LSH adaptor, MM, PC, beige, duplex, 2-hole flange

Features

- Automatic metal shutter in adaptor for dust protection and laser safety
- 2-hole flange
- Ideal for HighPower applications



Technical Data

General Data

| Characteristics | Values |
|-------------------|--------------------------|
| Specified acc. to | IEC 61754-15, TIA 604-16 |
| Adaptor family | LSH |
| Adaptor type | MM PC |
| Weight in kg | 0.0116 |
| Material | Plastic |
| Color of housing | Beige |

Mechanical Data

| Characteristics | Values |
|---------------------------------|--------|
| Operating temperature min. (°C) | -40 |
| Operating temperature max. (°C) | 85 |
| Min. mating cycles | 1000 |

Optical Data

| Characteristics | Values |
|-----------------|--------|
|-----------------|--------|

Environment Data

| Characteristics | Values |
|---------------------|-----------|
| RoHS compliant | Yes |
| REACH compliant | Yes |
| UV resistant | Yes |
| Flammability rating | UL 94 V-0 |

FLSH-FLSH-D101-02_100-P

Technical drawing

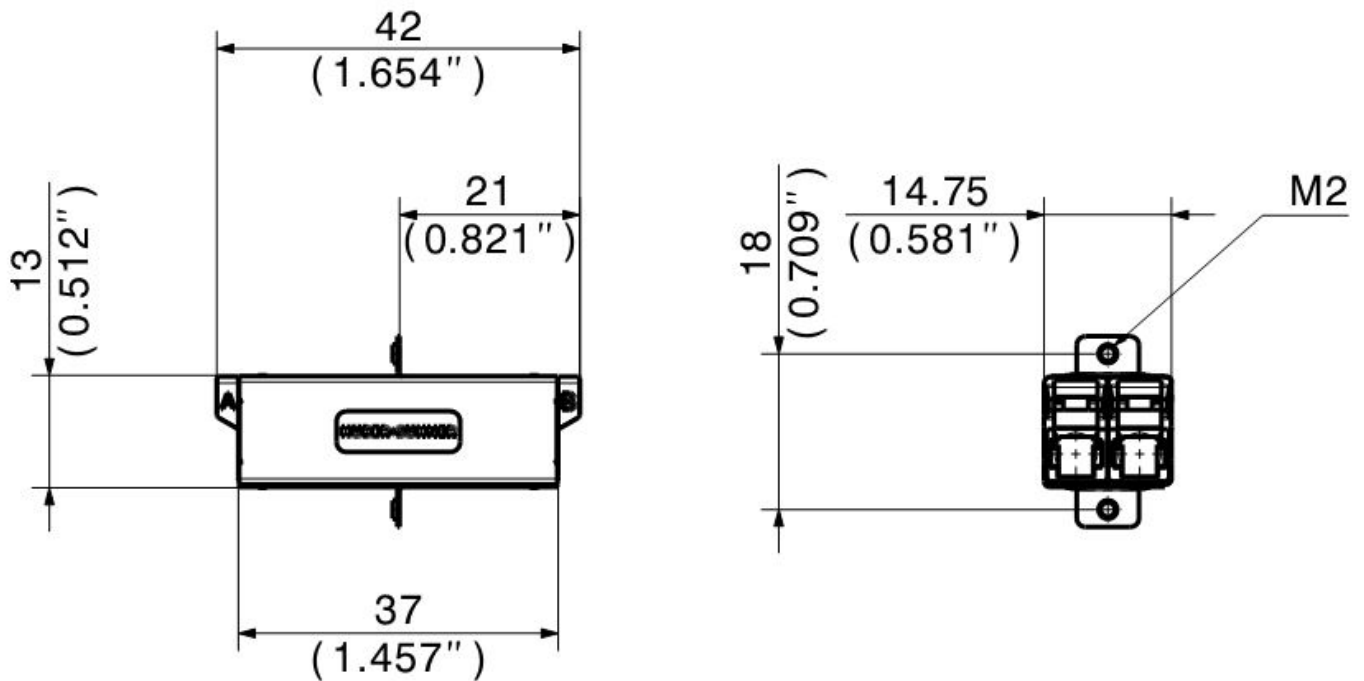

Ordering information

| Description | Item number |
|-------------------------|-------------|
| FLSH-FLSH-D101-02_100-P | 84098382 |