

FLSH-FLSH-A150_100-P

Description

LSH adaptor, SM, UPC, blue, simplex, integrated fixing spring

Features

- Automatic metal shutter in adaptor for dust protection and laser safety
- Solid 2-piece design
- Ideal for HighPower applications

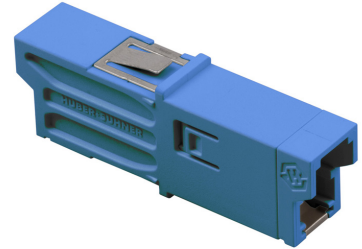

Technical Data

General Data

Characteristics	Values
Specified acc. to	IEC 61754-15 / TIA 604-16
Adaptor family	LSH
Adaptor type	SM UPC
Weight in kg	0.0042
Material	Plastic
Color of housing	Blue

Mechanical Data

Characteristics	Values
Operating temperature min. (°C)	-40
Operating temperature max. (°C)	85
Min. mating cycles	1000

Optical Data

Characteristics	Values
-----------------	--------

Environment Data

Characteristics	Values
RoHS compliant	Yes
REACH compliant	Yes
UV resistant	Yes
Flammability rating	UL 94 V-0

FLSH-FLSH-A150_100-P

Technical drawing

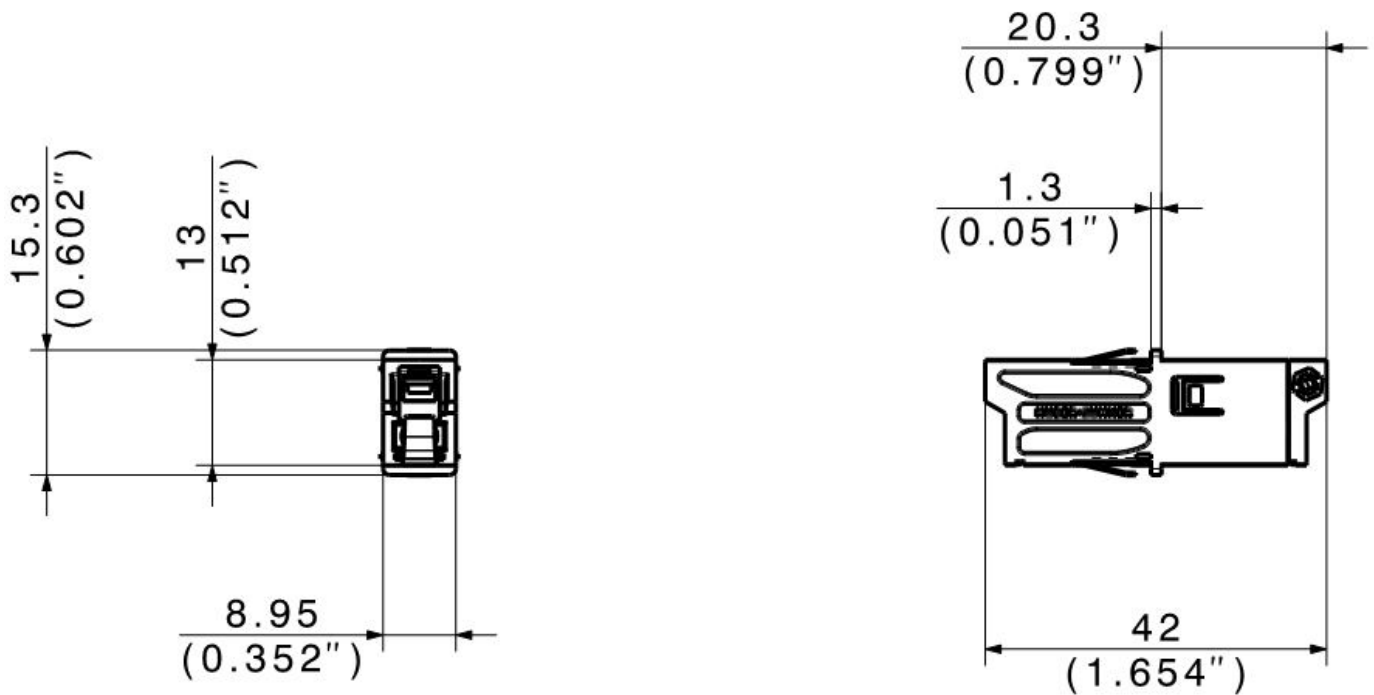

Ordering information

Description	Item number
FLSH-FLSH-A150_100-P	85026792