

FLC-FLC-D104-02_100-P

Description

FLC adaptor, SM, UPC, blue, duplex, internal shutter, 2-hole flange

Features

- Two connections in one SC-shaped adaptor
- One-piece design for highest precision
- Integrated fixing spring, 2-hole flange
- Ceramic sleeves
- Internal shutter

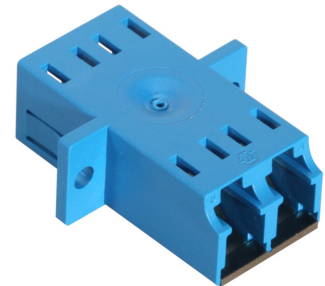

Technical Data

General Data

Characteristics	Values
Specified acc. to	IEC 61754-20, TIA 604-10-A
Adaptor family	LC
Adaptor type	SM UPC,
Weight in kg	0.0041
Material	Plastic
Color of housing	Blue

Mechanical Data

Characteristics	Values
Operating temperature min. (°C)	-40
Operating temperature max. (°C)	85
Min. mating cycles	1000

Optical Data

Characteristics	Values
IL repeatability (dB)	0.1

Environment Data

Characteristics	Values
RoHS compliant	Yes
REACH compliant	Yes
UV resistant	Yes
Flammability rating	UL 94 V-0
Free of halogen	Yes

FLC-FLC-D104-02_100-P

Technical drawing

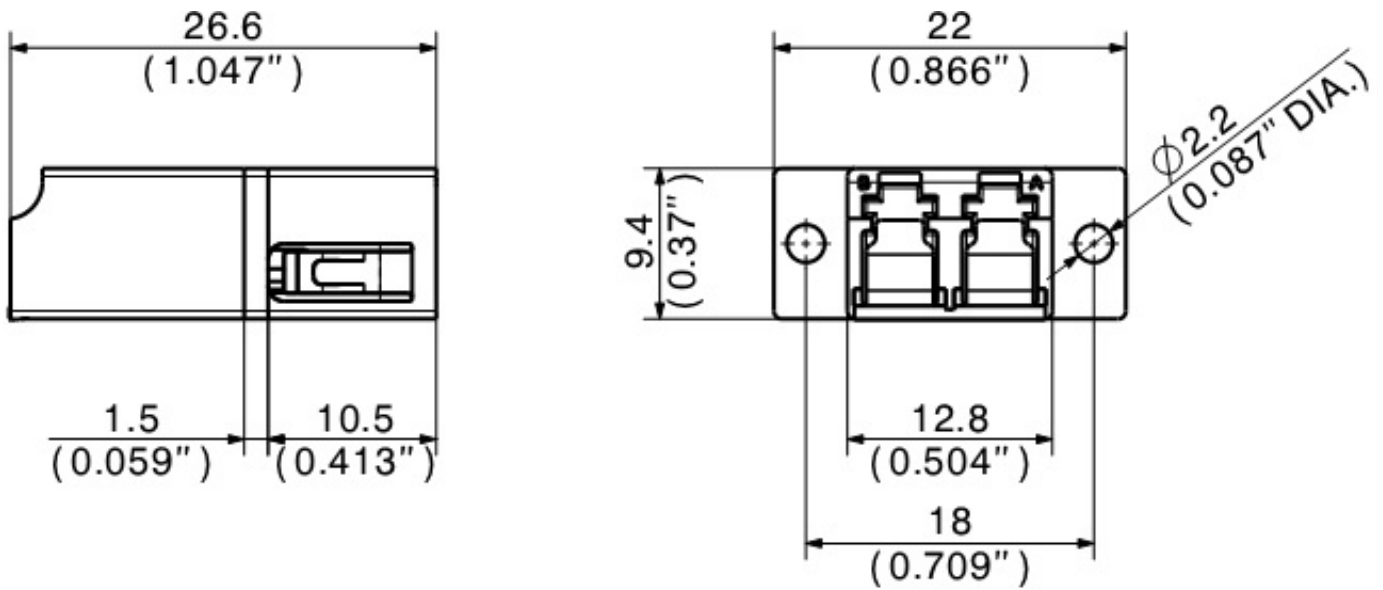

Ordering information

Description	Item number
FLC-FLC-D104-02_100-P	85002201