



MARINE ANTENNAS

PROCOM A/S



Home	1
S.M2	4
S.8Y series	7
S.6Y series	10
S.4Y series	13
S.3Y series	16
S.2Y series	20
S.1H series	23
S.1 series	26
RX 5000	29
TWA 1	31
SF 160/...	33
NTA 3E-SHT	36
Marifix 1 / Marifix 2 / ADT / MBS	38
MARCELL 3+	42
MARCELL	46
MA DAB SC	50
MA 70/GPS 4/...	53
MA 2-1 SC-SHT	58
MA 2-1 SC	61
MA 2-1 MR	64
GPS 4/...	67
GPS 2000	71
GPS 100 KT-FME	76
GP 80 B/...	79
GP 80/160	81
GP 80	83
GP 450-3/...	85
HF 7500-3	87
GP 450/...	89
HF 5000	91
GP 40	93
GP 160 B	95
GP 160 5/8	97
GP 160	99
CXL 2400-6LW/...	101
CXL 2400-3/...	104
CXL 2/70C	107
CXL 2-5HD/...	110
CXL 2-3LW/...	113
CXL 2-3C/...	116
CXL 2-3	119
CXL 1800-6/DECT	122
CXL 2-2C	125
CXL 2-1LW/...	128
CXL 2-1/...	131
CXL 108-185C	134

BCL 1-KA	137
AAC 1/...	141
CXL VHF/GSM	144
CXL 900-1/...	147
CXL 900-3/...	150
CXL 900/1800/1900/UMTS	153
CXL 70-3LW/...	155
CXL 450-6HD/T-X/...	158
CXL 70-3C/...	160
G-CXL 2-2C	163
G-CXL 2-1LW/...	166
CXL 5700-6	169
CXL 5700-3	172
CXL 5200-6LW	175
CXL 5700-1/...	178
BPF 2/...-250	181
AIS 2/GPS 4	183
R 2-3/..., R 2-6/...	188
R 2-8/..., R 2-10/...	191
DP 70/...	194
R 70-3/..., R 70-7/..., R 70-10/...	196
DP 4/...	199
CXL 150-1LW-SS-R/...	202
S.M4	205
CXL 2000-6/...	208
CXL 2000-3	211
CXL 2000-8LW/...	214
CXL 1090-1	217
CXL 1090-1LW	219
GPS/Iridium-FME	221
CXL 70-3HD/...-PT	223
CXL 450-3HD/T-X/...	226
End	228



S.M2

Two element stacked dipole array

- The S.M2 are an array of two centre fed folded dipoles mounted on an aluminium mast.
- Each folded dipole balun assembly and associated harness junction is completely encapsulated in epoxy resin, totally preventing moisture ingress.
- The balun assembly has been tested to BS5490:IP67.

Description

- The parallel feed enables beam tilt to be easily achieved, and the dipoles can be reorientated to shape the beam pattern.
- At VHF the antenna disassembles and flat packs for ease of shipping.

ORDERING DESIGNATIONS

TYPE	FREQUENCY	PRODUCT NO.
S.M2-127	117 - 137 MHz	123003110
S.M2-165	155 - 175 MHz	123003111
S.M2-184	176 - 192 MHz	123003112
S.M2-200	192 - 208 MHz	123003113
S.M2-405	380 - 430 MHz	123003114
S.M2-445	420 - 470 MHz	123003115

Specifications

TYPE	PRODUCT NO.
UA66-22	123001005
2140.01.00.00	123001012
2141.01.00.00	123001013
ELECTRIAL	
FREQUENCY RANGE	117 - 470 MHz
INPUT IMPEDANCE	50Ω
BANDWIDTH	± 4% of centre frequency
SWR	<1.5:1
FRONT TO BACK RATIO	5.5 dB
MAXIMUM INPUT POWER	250 Watts

POLARISATION	Vertical
FORWARD GAIN	5 dBd
3 dB BEAMWIDTH	E Plane 36° H Plane 180°
MECHANICAL	
STANDARD CONNECTION	3 m (118.11 in.) Length of RG 213 c/w 'N' type socket
ELEMENTS	12.7 mm dia. x 1.6 mm wall aluminium alloy grade 6063T6
SUPPORT BOOM UHF	UHF 38.1 mm dia. x 3.2 mm wall aluminium alloy grade 6082T6
SUPPORT BOOM VHF	VHF 63.5 mm dia. x 6.3 mm wall aluminium alloy grade 6082T6
FASTENERS	Stainless steel grade A2-70
DIPOLE CLAMPS	Cast aluminium alloy
DIPOLE ADJUSTMENT	M8 stainless steel screws
SADDLE CLAMPS	Diecast zinc alloy
INSULATOR	Epoxy resin encapsulant
LIGHTNING PROTECTION	Direct grounded VHF lightning finial
MOUNTING BRACKETS UHF	UHF fit inside scaffold pole
MOUNTING BRACKETS VHF	VHF to suit structure
TYPICAL WEIGHT (UHF)	UHF 4 kg (8.82 lb.)
TYPICAL WEIGHT (VHF)	VHF 9 kg (19.84 lb.)
TYPICAL LENGTH (UHF)	UHF 1.25 m (49.21 in.)
TYPICAL LENGTH (VHF)	VHF 4 m (157.48 in.)
TYPICAL WIND LOADING @ 162 km/h (UHF)	UHF 85N
TYPICAL WIND LOADING @ 162 km/h (VHF)	VHF 292N

MOUNTING ACCESSORIES

Mounting accessories to be ordered separately.



UA66-22

Very strong square cast alloy clamp, fits up to 50 mm diameter tubes as either a cross-over or parallel clamp. Supplied with two stainless steel 'U' bolts.



2140.01.00.00

Parallel clamps, in galvanised steel with stainless steel fixings, fits from 25-60 mm diameter tubes.



2141.01.00.00

Parallel clamps, in galvanised steel with stainless steel fixings, fits from 38-120 mm diameter tubes.



TYPICAL RADIATION PATTERN (E-PLANE)

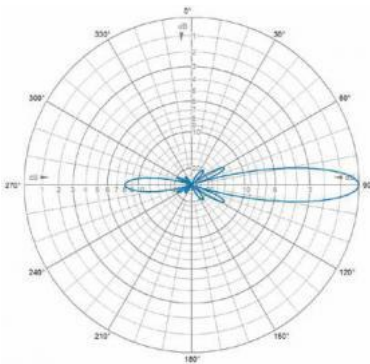

TYPICAL RADIATION PATTERN (H-PLANE)

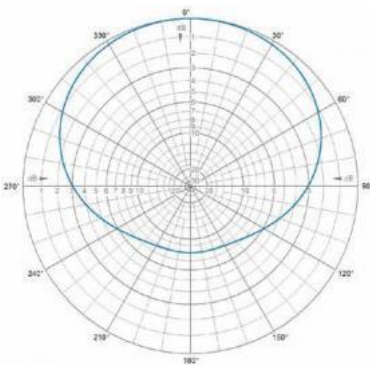



S.8Y series

Directional antennas

- The S.8Y series are of a rugged and reliable construction for long range communication networks at both UHF & VHF.
- The one piece folded dipole incorporates a d.c. short to minimise static interference.
- The balun assembly is completely encapsulated in epoxy resin, totally preventing moisture ingress, and has been tested to BS5490:IP67.

- These antennas give a gain of 10 dBd with front to back ratio typically 18 dB.
- They are supplied as standard with 3 metres of RG 213 cable terminated with an 'N' type socket, although cable and connector options are available upon request.
- The S.8Y is approved to MPT1411: Part 2.

ORDERING DESIGNATIONS

TYPE	FREQUENCY	PRODUCT NO.
S.8Y-155	145 - 165 MHz	123002080
S.8Y-165	155 - 165 MHz	123002081
S.8Y-405	380 - 430 MHz	123002082
S.8Y-445	420 - 470 MHz	123002083

SPECIFICATIONS

ELECTRIAL	
FREQUENCY RANGE	140 - 500 MHz
INPUT IMPEDANCE	50Ω
BANDWIDTH	± 4% of centre frequency
SWR	<1.5:1
FRONT TO BACK RATIO	18 dB
MAXIMUM INPUT POWER	150 Watts
POLARISATION	Vertical & horizontal
FORWARD GAIN	10 dBd
3 dB BEAMWIDTH	E Plane 43° H Plane 50°
MECHANICAL	
STANDARD CONNECTION	3 m (118.11 in.) Length of RG 213 c/w 'N' type socket
ELEMENTS UHF	UHF 12.7 mm dia. x 1.6 mm (0.50 in. dia x 0.06 in.) wall aluminium alloy grade 6063T6
ELEMENTS VHF	VHF 19.0 mm dia. x 1.6 mm

	(0.75 in. dia x 0.06 in.) wall aluminium alloy grade 6063T6
SUPPORT BOOM	31.7 mm dia. x 2.6 mm (1.25 in. dia x 0.10 in.) wall aluminium alloy grade 6082T6
FASTENERS	Stainless steel grade A2-70
SADDLE CLAMPS	Diecast zinc alloy
INSULATOR	Epoxy resin encapsulant
LIGHTNING PROTECTION	Direct grounded
MOUNTING BRACKETS	See mounting accessories (not supplied)
TYPICAL WEIGHT (UHF)	3 kg
TYPICAL WEIGHT (VHF)	5.2 kg
TYPICAL LENGTH (UHF)	1.6 m
TYPICAL LENGTH (VHF)	4 m
TYPICAL WIND LOADING @ 162 km/h (UHF)	UHF 100 N
TYPICAL WIND LOADING @ 162 km/h (VHF)	VHF 230 N

MOUNTING ACCESSORIES

Mounting accessories to be ordered separately.

TYPE	DIMENSION	PRODUCT NO.
1763-100		123001001
UA64-23	25 - 50 mm	123001006
UA64-23	25 - 76 mm	123001007
UA66-24	25 - 50 mm	123001017
UA66-24	25 - 76 mm	123001018
UA66-24	25 - 100 mm	123001019
UA66-24	25 - 115 mm	123001020



1763-100

Galvanised steel-cross-over clamp, fits 32 mm (1-1/4") diameter antenna booms to up to 50 mm (2") diameter poles, max. length 1500 mm.



UA64-23

Circular cast alloy clamp, gives a good two point fixing, supplied as standard with 4 x 50 mm stainless steel 'U' bolts and two half-moon cast spacers to fit antenna booms of 25 to 50 mm diameter. Will also accommodate 76 mm (3") 'U' bolts to fit masts of that diameter. (order UB06).



UA66-24

Rectangular cast alloy clamp, gives a good two point fixing, supplied as standard with 4 x 50 mm stainless steel 'U' bolts and two half-moon cast spacers to fit antenna booms of 25 to 50 mm diameter. To fit 76 mm (3") masts (order UB06 'U' bolts). To fit 100 mm (4") masts (order UB07 'U' bolts). To fit 115 mm (4 1/2") masts (order UB09 'U' bolts).

TYPICAL RADIATION PATTERN (E-PLANE)

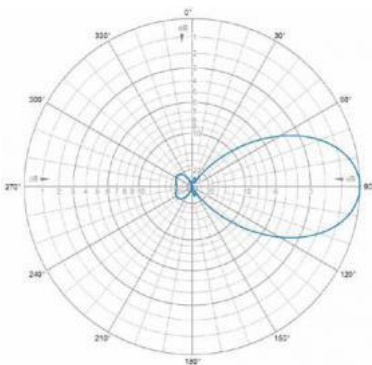

If the antennas are mounted for vertical polarization, these curves show the radiation patterns in the vertical plane.

TYPICAL RADIATION PATTERN (H-PLANE)

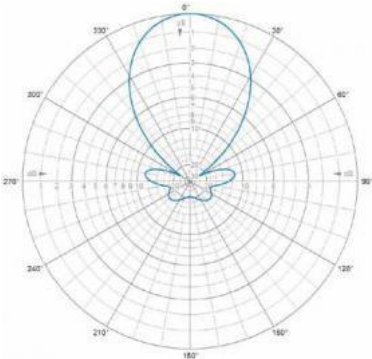

If the antennas are mounted for vertical polarization, these curves show the radiation patterns in the horizontal plane (horizontal coverage).



S.6Y series

Directional antennas

- The S.6Y series are of a rugged and reliable construction for communication networks at both UHF & VHF.
- The one piece folded dipole incorporates a d.c. short to minimise static interference.
- The balun assembly is completely encapsulated in epoxy resin, totally preventing moisture ingress, and has been tested to BS5490:IP67.

- These antennas give a gain of 8.5 dBd with front to back ratio typically 16 dB.
- They are supplied as standard with 3 metres of RG 213 cable terminated with an 'N' type socket, although cable and connector options are available upon request.

ORDERING DESIGNATIONS

TYPE	FREQUENCY	PRODUCT NO.
S.6Y-148	140 - 155 MHz	123002060
S.6Y-165	156 - 175 MHz	123002061
S.6Y-184	176 - 192 MHz	123002062
S.6Y-200	192 - 208 MHz	123002063
S.6Y-395	380 - 410 MHz	123002064
S.6Y-420	410 - 430 MHz	123002065
S.6Y-445	420 - 470 MHz	123002066

SPECIFICATIONS

ELECTRIAL	
FREQUENCY RANGE	140 - 470 MHz
INPUT IMPEDANCE	50Ω
BANDWIDTH	± 5% of centre frequency
SWR	<1.5:1
FRONT TO BACK RATIO	16 dB
MAXIMUM INPUT POWER	150 Watts
POLARISATION	Vertical & horizontal
FORWARD GAIN	8.5 dBd
3 dB BEAMWIDTH	E Plane 56° H Plane 63°
MECHANICAL	
STANDARD CONNECTION	3 m (118.11 in.) Length of RG 213 c/w 'N' type socket

ELEMENTS UHF	UHF 12.7 mm dia. x 1.6 mm (0.50 in. dia x 0.06 in.) wall aluminium alloy grade 6063T6
ELEMENTS VHF	VHF 19.0 mm dia. x 1.6 mm (0.75 in. dia x 0.06 in.) wall aluminium alloy grade 6063T6
SUPPORT BOOM	31.7 mm dia. x 2.6 mm (1.25 in. dia x 0.10 in.) wall aluminium alloy grade 6082T6
FASTENERS	Stainless steel grade A2-70
SADDLE CLAMPS	Diecast zinc alloy
INSULATOR	Epoxy resin encapsulant
LIGHTNING PROTECTION	Direct grounded
MOUNTING BRACKETS	See mounting accessories (not supplied)
TYPICAL WEIGHT (UHF)	UHF 2.7 kg (5.95 lb.)
TYPICAL WEIGHT (VHF)	VHF 5.5 kg (12.13 lb.)
TYPICAL LENGTH (UHF)	UHF 1.3 m (51.18 in.)
TYPICAL LENGTH (VHF)	VHF 4 m (157.48 in.)
TYPICAL WIND LOADING @ 162 km/h (UHF)	UHF 100 N
TYPICAL WIND LOADING @ 162 km/h (VHF)	VHF 208 N

MOUNTING ACCESSORIES

Mounting accessories to be ordered separately.

TYPE	DIMENSION	PRODUCT NO.
1763-100		123001001
UA64-23	25 - 50 mm	123001006
UA64-23	25 - 76 mm	123001007
UA66-24	25 - 50 mm	123001017
UA66-24	25 - 76 mm	123001018
UA66-24	25 - 100 mm	123001019
UA66-24	25 - 115 mm	123001020



1763-100

Galvanised steel-cross-over clamp, fits 32 mm (1-1/4") diameter antenna booms to up to 50 mm (2") diameter poles, max. length 1500 mm.



UA64-23

Circular cast alloy clamp, gives a good two point fixing, supplied as standard with 4 x 50 mm stainless steel 'U' bolts and two half-moon cast spacers to fit antenna booms of 25 to 50 mm diameter. Will also accomodate 76 mm (3") 'U' bolts to fit masts of that diameter. (order UB06).



UA66-24

Rectangular cast alloy clamp, gives a good two point fixing, supplied as standard with 4 x 50 mm stainless steel 'U' bolts and two half-moon cast spacers to fit antenna booms of 25 to 50 mm diameter. To fit 76 mm (3") masts (order UB06 'U' bolts). To fit 100 mm (4") masts (order UB07 'U' bolts). To fit 115 mm (4 1/2") masts (order UB09 'U' bolts).

TYPICAL RADIATION PATTERN (E-PLANE)

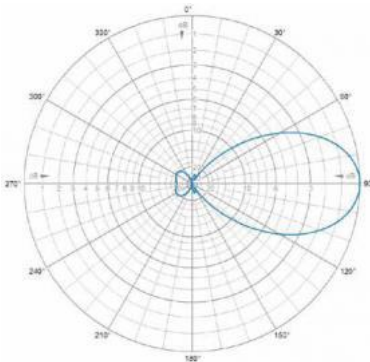

If the antennas are mounted for vertical polarization, these curves show the radiation patterns in the vertical plane.

TYPICAL RADIATION PATTERN (H-PLANE)

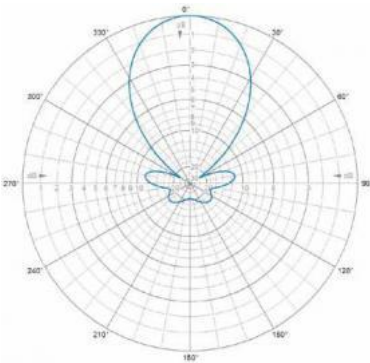

If the antennas are mounted for vertical polarization, these curves show the radiation patterns in the horizontal plane (horizontal coverage).



S.4Y series

Directional antennas

- The S.4Y series are of a rugged and reliable construction for communication networks at both UHF & VHF.
- The one piece folded dipole incorporates a d.c. short to minimise static interference.
- The balun assembly is completely encapsulated in epoxy resin, totally preventing moisture ingress, and has been tested to BS5490:IP67.

- These antennas give a gain of 7.5 dBd with front to back ratio typically 15 dB.
- They are supplied as standard with 3 metres of RG 213 cable terminated with an 'N' type socket, although cable and connector options are available upon request.

ORDERING DESIGNATIONS

TYPE	FREQUENCY	PRODUCT NO.
S.4Y-73	69 - 77 MHz	123002040
S.4Y-82	77 - 87 MHz	123002041
S.4Y-127	117 - 137 MHz	123002044
S.4Y-165	155 - 175 MHz	123002045
S.4Y-184	176 - 192 MHz	123002046
S.4Y-200	192 - 208 MHz	123002047
S.4Y-405	380 - 430 MHz	123002042
S.4Y-445	420 - 470 MHz	123002043

SPECIFICATIONS

ELECTRICAL	
FREQUENCY RANGE	69 - 470 MHz
INPUT IMPEDANCE	50Ω
BANDWIDTH	± 6% of centre frequency
SWR	<1.5:1
FRONT TO BACK RATIO	15 dB
MAXIMUM INPUT POWER	150 Watts
POLARISATION	Vertical & horizontal
FORWARD GAIN	7.5 dBd
3 dB BEAMWIDTH	E Plane 57° H Plane 74°
MECHANICAL	

STANDARD CONNECTION	3 m (118.11 in.) Length of RG 213 c/w 'N' type socket
ELEMENTS UHF	UHF 12.7 mm dia. x 1.6 mm (0.50 in. dia x 0.06 in.) wall aluminium alloy grade 6063T6
ELEMENTS VHF	VHF 19.0 mm dia. x 1.6 mm (0.75 in. dia x 0.06 in.) wall aluminium alloy grade 6063T6
SUPPORT BOOM	31.7 mm dia. x 2.6 mm (1.25 in. dia x 0.10 in.) wall aluminium alloy grade 6082T6
FASTENERS	Stainless steel grade A2-70
SADDLE CLAMPS	Diecast zinc alloy
INSULATOR	Epoxy resin encapsulant
LIGHTNING PROTECTION	Direct grounded
MOUNTING BRACKETS	See mounting accessories (not supplied)
TYPICAL WEIGHT (UHF)	UHF 2.3 kg (5.07 lb.)
TYPICAL WEIGHT (VHF)	VHF 6.0 kg (13.23 lb.)
TYPICAL LENGTH (UHF)	UHF 0.9 m (35.43 in.)
TYPICAL LENGTH (VHF)	VHF 3 m (118.11 in.)
TYPICAL WIND LOADING @ 162 km/h (UHF)	UHF 60 N
TYPICAL WIND LOADING @ 162 km/h (VHF)	VHF 340 N

MOUNTING ACCESSORIES

Mounting accessories to be ordered separately.

TYPE	DIMENSION	PRODUCT NO.
1763-100		123001001
UA64-23	25 - 50 mm	123001006
UA64-23	25 - 76 mm	123001007
UA66-24	25 - 50 mm	123001017
UA66-24	25 - 76 mm	123001018
UA66-24	25 - 100 mm	123001019
UA66-24	25 - 115 mm	123001020



1763-100

Galvanised steel-cross-over clamp, fits 32 mm (1-1/4") diameter antenna booms to up to 50 mm (2") diameter poles, max. length 1500 mm.



UA64-23

Circular cast alloy clamp, gives a good two point fixing, supplied as standard with 4 x 50 mm stainless steel 'U' bolts and two half-moon cast spacers to fit antenna booms of 25 to 50 mm diameter. Will also accommodate 76 mm (3") 'U' bolts to fit masts of that diameter. (order UB06).



UA66-24

Rectangular cast alloy clamp, gives a good two point fixing, supplied as standard with 4 x 50 mm stainless steel 'U' bolts and two half-moon cast spacers to fit antenna booms of 25 to 50 mm diameter. To fit 76 mm (3") masts (order UB06 'U' bolts). To fit 100 mm (4") masts (order UB07 'U' bolts). To fit 115 mm (4 1/2") masts (order UB09 'U' bolts).

TYPICAL RADIATION PATTERN (E-PLANE)

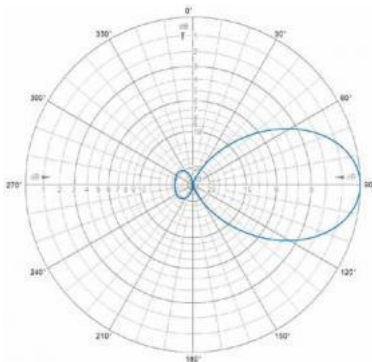

If the antennas are mounted for vertical polarization, these curves show the radiation patterns in the vertical plane.

TYPICAL RADIATION PATTERN (H-PLANE)

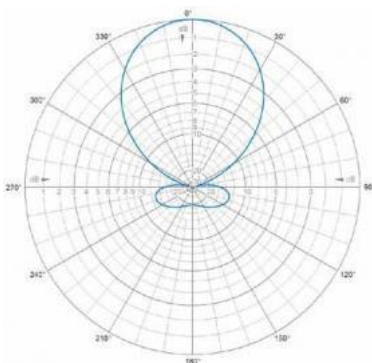

If the antennas are mounted for vertical polarization, these curves show the radiation patterns in the horizontal plane (horizontal coverage).



S.3Y series

Directional antennas

- The S.3Y series are of a rugged and reliable construction for communication networks at both UHF & VHF.
- The one piece folded dipole incorporates a d.c. short to minimise static interference.
- The balun assembly is completely encapsulated in epoxy resin, totally preventing moisture ingress, and has been tested to BS5490:IP67.

- These antennas give a gain of 6dBd with front to back ratio typ. 15 dB.
- They are supplied as standard with 3 metres of RG 213 cable terminated with an 'N' type socket, although cable and connector options are available upon request.

ORDERING DESIGNATIONS

TYPE	FREQUENCY	PRODUCT NO.
S.3Y-71	66 - 75 MHz	123002030
S.3Y-80	75 - 85 MHz	123002031
S.3Y-98	88 - 108 MHz	123002032
S.3Y-127	117 - 137 MHz	123002033
S.3Y-142	135 - 149 MHz	123002034
S.3Y-155	145- 165 MHz	123002035
S.3Y-165	155 - 175 MHz	123002036
S.3Y-184	176 - 192 MHz	123002037
S.3Y-200	192 - 208 MHz	123002038
S.3Y-395	380 - 410 MHz	123002039
S.3Y-420	410 - 430 MHz	123002048
S.3Y-445	420 - 470 MHz	123002049

SPECIFICATIONS

ELECTRICAL	
FREQUENCY RANGE	66 - 470 MHz
INPUT IMPEDANCE	50Ω
BANDWIDTH	± 6% of centre frequency
SWR	<1.5:1
FRONT TO BACK RATIO	15 dB
MAXIMUM INPUT POWER	150 Watts
POLARISATION	Vertical & horizontal

FORWARD GAIN	6 dBd
3 dB BEAMWIDTH	E Plane 62° H Plane 84°
MECHANICAL	
STANDARD CONNECTION	3m (118.11 in.) Length of RG 213 c/w 'N' type socket
ELEMENTS UHF	UHF 12.7 mm dia. x 1.6 mm (0.50 in. dia x 0.06 in.) wall aluminium alloy grade 6063T6
ELEMENTS VHF	VHF 19.0 mm dia. x 1.6 mm (0.75 in. dia x 0.06 in.) wall aluminium alloy grade 6063T6
SUPPORT BOOM	31.7 mm dia. x 2.6 mm (1.25 in. dia x 0.10 in.) wall aluminium alloy grade 6082T6
FASTENERS	Stainless steel grade A2-70
SADDLE CLAMPS	Diecast zinc alloy
INSULATOR	Epoxy resin encapsulant
LIGHTNING PROTECTION	Direct grounded
MOUNTING BRACKETS	See mounting accessories (not supplied)
TYPICAL WEIGHT (UHF)	UHF 1.5 kg (3.31 lb.)
TYPICAL WEIGHT (VHF)	VHF 4.5 kg (9.92 lb.)
TYPICAL LENGTH (UHF)	UHF 0.7 m (27.56 in.)
TYPICAL LENGTH (VHF)	VHF 1.5 m (88.61 in.)
TYPICAL WIND LOADING @ 162 km/h (UHF)	UHF 52 N
TYPICAL WIND LOADING @ 162 km/h (VHF)	VHF 240 N

MOUNTING ACCESSORIES

Mounting accessories to be ordered separately.

TYPE	DIMENSION	PRODUCT NO.
1763-100		123001001
UA64-23	25 - 50 mm	123001006
UA64-23	25 - 76 mm	123001007
UA66-24	25 - 50 mm	123001017
UA66-24	25 - 76 mm	123001018
UA66-24	25 - 100 mm	123001019
UA66-24	25 - 115 mm	123001020



1763-100

Galvanised steel-cross-over clamp, fits 32 mm (1-1/4") diameter antenna booms to up to 50 mm (2") diameter poles, max. length 1500 mm.



UA64-23

Circular cast alloy clamp, gives a good two point fixing, supplied as standard with 4 x 50 mm stainless steel 'U' bolts and two half-moon cast spacers to fit antenna booms of 25 to 50 mm diameter. Will also accomodate 76 mm (3") 'U' bolts to fit masts of that diameter. (order UB06).



UA66-24

Rectangular cast alloy clamp, gives a good two point fixing, supplied as standard with 4 x 50 mm stainless steel 'U' bolts and two half-moon cast spacers to fit antenna booms of 25 to 50 mm diameter.

To fit 76 mm (3") masts (order UB06 'U' bolts).

To fit 100 mm (4") masts (order UB07 'U' bolts).

To fit 115 mm (4 1/2") masts (order UB09 'U' bolts).

TYPICAL RADIATION PATTERN (E-PLANE)

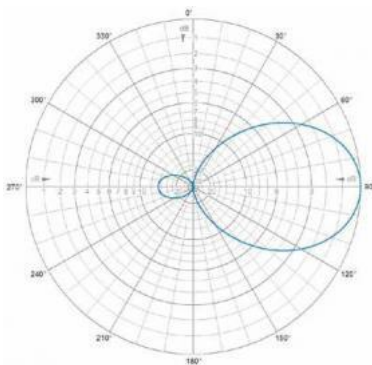

If the antennas are mounted for vertical polarization, these curves show the radiation patterns in the vertical plane.

TYPICAL RADIATION PATTERN (H-PLANE)

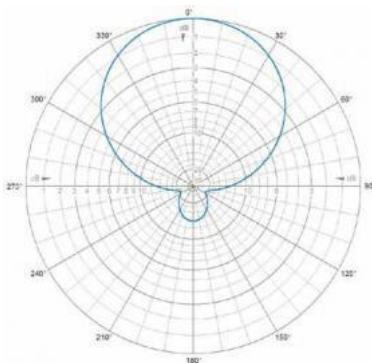



If the antennas are mounted for vertical polarization, these curves show the radiation patterns in the horizontal plane (horizontal coverage).



S.2Y series

Directional antennas

- The S.2Y series are of a rugged and reliable construction for communication networks at both UHF & VHF.
- The one piece folded dipole incorporates a d.c. short to minimise static interference.
- The balun assembly is completely encapsulated in epoxy resin, totally preventing moisture ingress, and has been tested to BS5490:IP67.

- These antennas give a gain of 3 dBd with front to back ratio typ. 13 dB.
- They are supplied as standard with 3 metres of RG 213 cable terminated with an 'N' type socket, although cable and connector options are available upon request.

ORDERING DESIGNATIONS

TYPE	FREQUENCY	PRODUCT NO.
S.2Y-72	67 - 76 MHz	123002020
S.2Y-82	77 - 86 MHz	123002021
S.2Y-155	145 - 165 MHz	123002022
S.2Y-165	156 - 175 MHz	123002023
S.2Y-405	376 - 424 MHz	123002024
S.2Y-410	385 - 435 MHz	123002025
S.2Y-445	420 - 470 MHz	123002026

SPECIFICATIONS

ELECTRICAL	
FREQUENCY RANGE	67 - 470 MHz
INPUT IMPEDANCE	50Ω
BANDWIDTH	± 6% of centre frequency
SWR	<1.5:1
FRONT TO BACK RATIO	13 dB
MAXIMUM INPUT POWER	150 Watts
POLARISATION	Vertical & horizontal
FORWARD GAIN	3 dBd
3 dB BEAMWIDTH	E Plane 72° H Plane 144°
MECHANICAL	
STANDARD CONNECTION	3 m (118.11 in.) Length of RG 213 c/w 'N' type socket

ELEMENTS UHF	UHF 12.7 mm dia. x 1.6 mm (0.50 in. dia x 0.06 in.) wall aluminium alloy grade 6063T6
ELEMENTS VHF	VHF 19.0 mm dia. x 1.6 mm (0.75 in. dia x 0.06 in.) wall aluminium alloy grade 6063T6
SUPPORT BOOM	31.7 mm dia. x 2.6 mm (1.25 in. dia x 0.10 in.) wall aluminium alloy grade 6082T6
FASTENERS	Stainless steel grade A2-70
SADDLE CLAMPS	Diecast zinc alloy
INSULATOR	Epoxy resin encapsulant
LIGHTNING PROTECTION	Direct grounded
MOUNTING BRACKETS	See mounting accessories (not supplied)
TYPICAL WEIGHT (UHF)	UHF 1.3 kg (2.87 lb.)
TYPICAL WEIGHT (VHF)	VHF 3.5 kg (7.71 lb.)
TYPICAL LENGTH (UHF)	UHF 0.6 m (23.62 in.)
TYPICAL LENGTH (VHF)	VHF 1.5 m (59.06 in.)
TYPICAL WIND LOADING @ 162 km/h (UHF)	UHF 50 N
TYPICAL WIND LOADING @ 162 km/h (VHF)	VHF 180 N

MOUNTING ACCESSORIES

Mounting accessories to be ordered separately.

TYPE	DIMENSION	PRODUCT NO.
1763-100		123001001
UA64-23	25 - 50 mm	123001006
UA64-23	25 - 76 mm	123001007
UA66-24	25 - 50 mm	123001017
UA66-24	25 - 76 mm	123001018
UA66-24	25 - 100 mm	123001019
UA66-24	25 - 115 mm	123001020



1763-100

Galvanised steel-cross-over clamp, fits 32 mm (1-1/4") diameter antenna booms to up to 50 mm (2") diameter poles, max. length 1500 mm.



UA64-23

Circular cast alloy clamp, gives a good two point fixing, supplied as standard with 4 x 50 mm stainless steel 'U' bolts and two half-moon cast spacers to fit antenna booms of 25 to 50 mm diameter. Will also accomodate 76 mm (3") 'U' bolts to fit masts of that diameter. (order UB06).



UA66-24

Rectangular cast alloy clamp, gives a good two point fixing, supplied as standard with 4 x 50 mm stainless steel 'U' bolts and two half-moon cast spacers to fit antenna booms of 25 to 50 mm diameter.

To fit 76 mm (3") masts (order UB06 'U' bolts).

To fit 100 mm (4") masts (order UB07 'U' bolts).

To fit 115 mm (4 1/2") masts (order UB09 'U' bolts).

TYPICAL RADIATION PATTERN (E-PLANE)

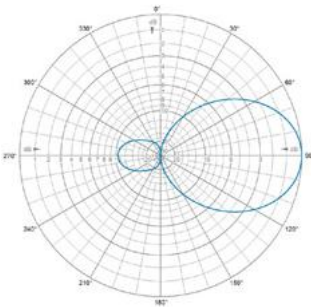

If the antennas are mounted for vertical polarization, these curves show the radiation patterns in the vertical plane.

TYPICAL RADIATION PATTERN (H-PLANE)

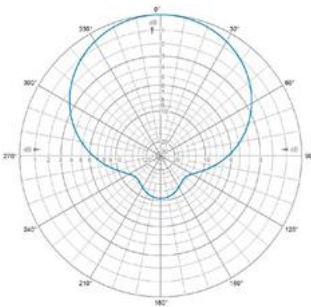

If the antennas are mounted for vertical polarization, these curves show the radiation patterns in the horizontal plane (horizontal coverage).



S.1H series

Heavy duty centre-fed folded dipole antenna.

- The S.1H series are designed for use in extreme environments, or for multi channel applications.
- The one piece folded dipole assembly incorporates a d.c. short and is completely encapsulated in epoxy resin, totally preventing moisture ingress.
- A sleeve is welded to the dipole to increase strength, and improve VSWR.

- These antennas can be arranged in a variety of arrays to produce a wide range of radiation patterns.
- They are supplied as standard with 3 m of RG 213 cable terminated with an 'N' type socket.

ORDERING DESIGNATIONS

TYPE	FREQUENCY	PRODUCT NO.
S.1H-78	66 - 88 MHz	123003020
S.1H-98	88 - 108 MHz	123003021
S.1H-127	117 - 137 MHz	123003022
S.1H-165	155 - 175 MHz	123003023

SPECIFICATIONS

ELECTRICAL	
FREQUENCY RANGE	66 - 175 MHz
INPUT IMPEDANCE	50Ω
BANDWIDTH	± 10% of centre frequency
SWR	<1.5:1
FRONT TO BACK RATIO	4 dB
MAXIMUM INPUT POWER	500 Watts
POLARISATION	Vertical
FORWARD GAIN	2 dBd
3 dB BEAMWIDTH	E Plane 85° H Plane 200° (Gain & RPE assumes mount on conductive pole)
MECHANICAL	
STANDARD CONNECTION	3 m (118.11 in.) Length of RG 213 c/w 'N' type socket
ELEMENTS	19.0 mm dia. x 1.6 mm (0.75 in. dia x 0.06 in.) wall aluminium alloy grade 6063T6

DIPOLE SLEEVE (WELDED)	31.7 mm dia. x 2.6 mm (1.25 in. dia x 0.10 in.) wall aluminium alloy grade 6063T6
SUPPORT BOOM	48.4 mm dia. x 4.5 mm (1.91 in. dia x 0.18 in.) wall aluminium alloy grade 6082T6
FASTENERS	Stainless steel grade A2-70
SADDLE CLAMPS	Machined aluminium alloy
INSULATOR	Epoxy resin encapsulant
LIGHTNING PROTECTION	Direct grounded
MOUNTING BRACKETS	See mounting accessories (not supplied)
TYPICAL WEIGHT	5.3 kg (11.68 lb.)
TYPICAL LENGTH	1.5 m (59.06 in.)
TYPICAL WIND LOADING @ 162 km/h	202 N

MOUNTING ACCESSORIES

Mounting accessories to be ordered separately.

TYPE	DIMENSION	PRODUCT NO.
1763-100		123001001
UA64-23	25 - 50 mm	123001006
UA64-23	25 - 76 mm	123001007
UA66-24	25 - 50 mm	123001017
UA66-24	25 - 76 mm	123001018
UA66-24	25 - 100 mm	123001019
UA66-24	25 - 115 mm	123001020



1763-100

Galvanised steel-cross-over clamp, fits 32 mm (1-1/4") diameter antenna booms to up to 50 mm (2") diameter poles, max. length 1500 mm.



UA64-23

Circular cast alloy clamp, gives a good two point fixing, supplied as standard with 4 x 50 mm stainless steel 'U' bolts and two half-moon cast spacers to fit antenna booms of 25 to 50 mm diameter. Will also accomodate 76 mm (3") 'U' bolts to fit masts of that diameter. (order UB06).



UA66-24

Rectangular cast alloy clamp, gives a good two point fixing, supplied as standard with 4 x 50 mm stainless steel 'U' bolts and two half-moon cast spacers to fit antenna booms of 25 to 50 mm diameter.

To fit 76 mm (3") masts (order UB06 'U' bolts).

To fit 100 mm (4") masts (order UB07 'U' bolts).

To fit 115 mm (4 1/2") masts (order UB09 'U' bolts).

TYPICAL RADIATION PATTERN (E-PLANE)

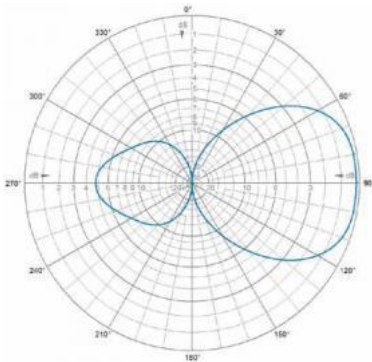

TYPICAL RADIATION PATTERN (H-PLANE)

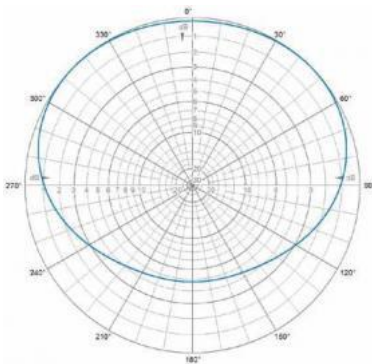



S.1 series

Centre-fed folded dipole antenna.

- The S.1 series are of a rugged and reliable construction.
- The one piece folded dipole incorporates a d.c. short to minimise static interference.
- The balun assembly is completely encapsulated in epoxy resin, totally preventing moisture ingress, and has been tested to BS5490:IP67.

- These antennas can be arranged in a variety of arrays in combination with CPS (cable power splitter) series to produce a wide range of radiation patterns.
- They are supplied as standard with 3 metres of RG 213 cable terminated with an 'N' type socket.
- Heavy duty and stainless steel options are available.

ORDERING DESIGNATIONS

TYPE	FREQUENCY	PRODUCT NO.
S.1-72	66 - 80 MHz	123003001
S.1-82	70 - 86 MHz	123003002
S.1-98	88 - 108 MHz	123003003
S.1-127	117 - 137 MHz	123003008
S.1-160	145 - 176 MHz	123003004
S.1-200	192 - 208 MHz	123003009
S.1-405	380 - 430 MHz	123003005
S.1-380-470	380 - 470 MHz	123003010
S.1-445	420 - 470 MHz	123003006
S.1-475	430 - 520 MHz	123003007

SPECIFICATIONS

ELECTRICAL	
FREQUENCY RANGE	66 - 520 MHz
INPUT IMPEDANCE	50 Ω
BANDWIDTH	± 10% of centre frequency
SWR	< 1.5:1
FRONT TO BACK RATIO	4 dB
MAXIMUM INPUT POWER	150 W
POLARIZATION	Vertical
FORWARD GAIN	2 dBd
3 dB BEAMWIDTH	E Plane 85° H Plane 200°

	(Gain & RPE assumes mount on conductive pole)
MECHANICAL	
STANDARD CONNECTION	3 m (118.11 in.) Length of RG 213 c/w 'N' type socket
ELEMENTS (UHF) (> 138 MHz)	UHF 12.7 mm dia. x 1.6 mm (0.50 in. dia x 0.06 in.) wall aluminium alloy grade 6063T6
ELEMENTS (VHF) (< 138 MHz)	VHF 19.0 mm dia. x 1.6 mm (0.75 in. dia x 0.06 in.) wall aluminium alloy grade 6063T6
SUPPORT BOOM	31.7 mm dia. x 2.6 mm (1.25 in. dia x 0.10 in.) wall aluminium alloy grade 6082T6
FASTENERS	Stainless steel grade A2-70
SADDLE CLAMPS	Diecast zinc alloy
INSULATOR	Epoxy resin encapsulant
LIGHTNING PROTECTION	Direct grounded
MOUNTING BRACKETS	See mounting accessories (not supplied)
TYPICAL WEIGHT (UHF)	UHF 1.9 kg (4.19 lb.)
TYPICAL WEIGHT (VHF)	VHF 2.8 kg (6.17 lb.)
TYPICAL LENGTH (UHF)	UHF 1 m (39.37 in.)
TYPICAL LENGTH (VHF)	VHF 1.33 m (52.36 in.)
TYPICAL WIND LOADING @ 162 km/h (UHF)	UHF 54 N
TYPICAL WIND LOADING @ 162 km/h (VHF)	VHF 148 N

MOUNTING ACCESSORIES

Mounting accessories to be ordered separately.

TYPE	DIMENSION	PRODUCT NO.
1763-100		123001001
UA64-23	25 - 50 mm	123001006
UA64-23	25 - 76 mm	123001007
UA66-24	25 - 50 mm	123001017
UA66-24	25 - 76 mm	123001018
UA66-24	25 - 100 mm	123001019
UA66-24	25 - 115 mm	123001020



1763-100

Galvanised steel-cross-over clamp, fits 32 mm (1-1/4") diameter antenna booms to up to 50 mm (2") diameter poles, max. length 1500 mm.



UA64-23

Circular cast alloy clamp, gives a good two point fixing, supplied as standard with 4 x 50 mm stainless steel 'U' bolts and two half-moon cast spacers to fit antenna booms of 25 to 50 mm diameter. Will also accommodate 76 mm (3") 'U' bolts to fit masts of that diameter. (order UB06).



UA66-24

Rectangular cast alloy clamp, gives a good two point fixing, supplied as standard with 4 x 50 mm stainless steel 'U' bolts and two half-moon cast spacers to fit antenna booms of 25 to 50 mm diameter.

To fit 76 mm (3") masts (order UB06 'U' bolts).

To fit 100 mm (4") masts (order UB07 'U' bolts).

To fit 115 mm (4 1/2") masts (order UB09 'U' bolts).

TYPICAL RADIATION PATTERN (E-PLANE)

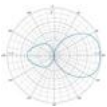

TYPICAL RADIATION PATTERN (H-PLANE)



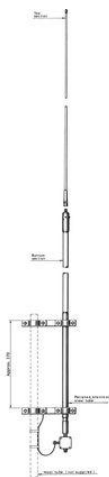

RX 5000

Self-Supporting Wide-Band Receiving Whip Antenna for the LF, MF and HF Bands.

- This antenna provides a very efficient means of establishing a universal, wide-band 50 Ω receiving aerial system for the complete LF, MF and HF bands in one unit.
- The antenna consists of a high-capacitance, 5 m long glass fibre antenna element with a frequency-compensated wide-band impedance transformer mounted in the bottom end.
- The transformer converts the widely varying antenna impedance to a constant 50 Ω, making it possible to use length-independent, shielded, standard RG 58 C/U or RG 213/U as download cable to the 50 Ω receiver.

- The antenna is protected against noise pick-up running on the outside of the download cable, and it is protected against static by DC-grounding.
- Moreover, the 50 Ω receiver and the matching transformer itself are protected against RF overload and violent discharges by an air spark gap (approx. 1 kV), a gas filled spark gap (90 V) and a resistance network.
- To prevent electrolytical corrosion, the coaxial cable braid is only capacitively coupled to the earth connection.
- Installation is easily carried out by means of the two hot galvanized mast clamps. The antenna has very small weight and minimum wind surface, thereby requiring only a minimum of mast strength.
- The glass fibre construction gives a stiff and self-supporting structure with extremely good resistance against the corrosive marine environment with UV-radiation, salt, exhaust gases and ice formation as primary factors.
- RX 5000 is a maintenance-free and very reliable construction.

ORDERING DESIGNATIONS

TYPE NO.	PRODUCT NO.
RX 5000	110000111

SPECIFICATIONS

ELECTRICAL	
MODEL	RX 5000
ANTENNA TYPE	Self-supporting wide-band receiving whip antenna for LF, MF and HF bands
FREQUENCY RANGE	100 kHz - 30 MHz
IMPEDANCE	50 Ω
POLARISATION	Vertical
MECHANICAL	
TEMP. RANGE	-30° → +70° C
CONNECTOR	"N"-female
WIND SURFACE	0.082 m ²
WIND LOAD	108 N @ 150 km/h
MAX. WIND SPEED	200 km/h

COLOUR	Marine white
MATERIALS	Shroud : Glass fibre, stainless steel and chromed brass Housing: Polycarbonate
TOTAL HEIGHT	Approx. 5.17 m (incl. box)
DIA. IN TOP END	5 mm
DIA. IN BOTTOM END	20 mm
WEIGHT	Approx. 2.9 kg (clamps inclusive)
MOUNTING	With side-mounting clamps on 35 - 65 mm dia. mast tube

CLAMP DETAILS

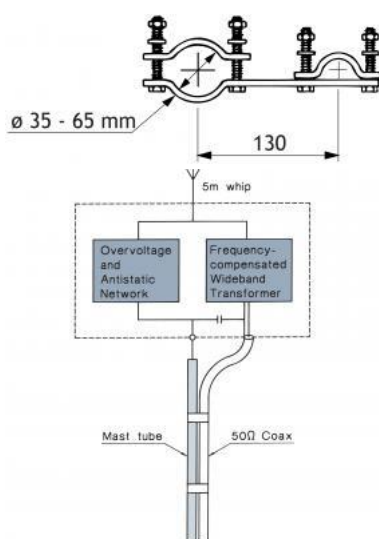

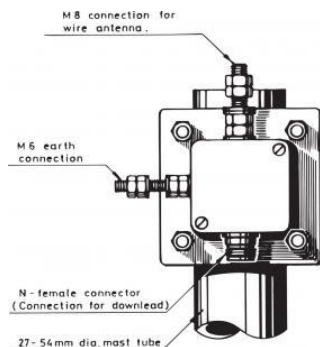

TWA 1

Broadband Transformer for Marine Wire Receiving Antennas

- Together with a wire receiving antenna this passive matching transformer provides a very efficient means of establishing a wideband 50 Ω receiving antenna system for the complete LF, MF and HF range.
- A typical installation can be seen on the figure below. The wire antenna is suspended with both ends insulated between two high points on the ship. The TWA 1 is mounted in immediate vicinity of one of the suspension points, and the antenna terminal of the TWA 1 is connected to the wire antenna.

DESCRIPTION

- The TWA 1 can be mounted on vertical or horizontal mast tubes, 30–54 mm in outer diameter and it can operate together with wire antennas with a length between 5 and 10 meters.
- The frequency compensated transformer converts the widely varying antenna impedance to a constant 50 Ω, making it possible to use length-independent, shielded, standard RG 58 C/U or RG 213/U as downlead cable to the 50 Ω receiver.
- For proper performance of the antenna system the separate earth terminal on the transformer must be connected to the mounting tube, and this mounting tube must be connected to the earth potential of the ship.
- This earthing procedure ensures a low-loss connection to ground for RF-signals and prevents noise pick-up from the ship's installations, running on the outside of the coaxial cable, in being coupled on-frequency to the wire antenna. As the earth terminal is AC-coupled, electrolytical corrosion is effectively prevented.
- The transformer and the 50 Ω receiver are protected against RF overload and violent discharges by an air spark gap (approx. 1 kV), a gas filled spark gap (90 V) and a resistance network.
- The transformer unit with protection circuits is built into a watertight UV-resistant polycarbonate box and, moreover, all circuitry is totally encapsulated in polyurethane sealer. The mounting plate as well as all accompanying fittings are made of stainless steel.

ORDERING DESIGNATIONS

TYPE NO.	PRODUCT NO.
TWA 1	110000113

SPECIFICATIONS

ELECTRICAL	
MODEL	TWA 1
TYPE	Broadband matching transformer for marine wire receiving antennas
FREQUENCY RANGE	100 kHz – 30 MHz
OUTPUT IMPEDANCE	Nom. 50 Ω
MIN. LENGTH OF WIRE ANT.	5 m
MAX. LENGTH OF WIRE ANT.	10 m
MECHANICAL	
TEMP. RANGE	-30° C → +70° C
CONN. TO ANTENNA	M8 thread stud
CONN. TO EARTH	M6 thread stud

CONN. TO DOWNLEAD	N-female
COLOUR	Light-grey
METERIALS	Clamps : Stainless steel Housing: Polycarbonate
WIDTH	95 mm
HEIGHT	100 mm
DEPTH	38 mm
WEIGHT	Approx. 450 g
MOUNTING	On vertical or horizontal mast tubes 30-54 mm in outer dia.

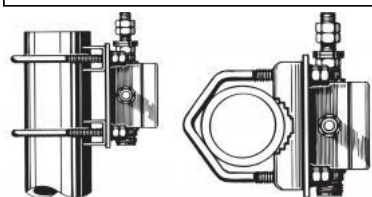

TYPICAL INSTALLATION:

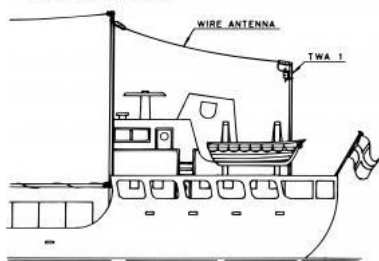

- The antenna terminal on the TWA 1 is not dimensioned to carry the pull from the antenna wire directly. The tension of the antenna wire must be relieved at a well insulated point before it is connected to the TWA 1.
- If the receiving range is restricted to 8 MHz and below, the wire antenna can advantageously be extended up to a length of 40 m.



SF 160/...

2 dB Mobile Sidefix® Antenna for the 1800 MHz Band

- End-fed half-wave dipole with a black-chromed, conical stainless steel whip.
- 2 dB gain compared to a standard $\frac{1}{4} \lambda$ roof mount antenna.

DESCRIPTION

- Groundplane independent due to half-wave design.
- For temporary antenna installations.
- Mounting on side-windows using a simple “clip-on” procedure.
- Provided with FME-connector (male).

ORDERING DESIGNATIONS

TYPE	PRODUCT NO.	FREQUENCY
SF 160/l	130000700	144 - 160 MHz
SF 160/m	130000702	155 - 170 MHz
SF 160/h	130000701	160 - 175 MHz

SPECIFICATIONS

ELECTRICAL	
MODEL	SF 160/...
ANTENNA TYPE	End-fed $\frac{1}{2} \lambda$ dipole mobile antenna
FREQUENCY	144 - 175 MHz covered by three models
IMPEDANCE	Nom. 50 Ω
POLARIZATION	Vertical
GAIN	2 dB (acc. to EIA RS-329-1)
BANDWIDTH	≥ 15 MHz @ SWR ≤ 2.0
SWR	≤ 1.3 @ f.res.
MAX. POWER	25 W
MECHANICAL	
MATERIALS	Whip: Black-chromed, conical stainless steel

	Black-chromed brass Mount: Weather- and shockproof plastics Black-chromed brass
CABLE	FME-cable to be ordered separately
COLOUR	Black
HEIGHT	Approx. 960 mm
WEIGHT	Approx. 140 g
MOUNTING	"Clip-on" mounting on the side-window
SIDE WINDOW THICKNESS	Max. 4 mm

FME-SYSTEM ACCESSORIES

FME-CABLES	
TYPE	LENGTH
1 m FME	1 m
2 m FME	2 m
3 m FME	3 m
4 m FME	4 m
5 m FME	5 m
6 m FME	6 m
4 m FME-white	4 m white
6 m FME-white	6 m white
12 m FME-white	12 m white
18 m FME-white	18 m white
FME-CONNECTORS	
TYPE	CONNECTOR
FME-FME	FME-FME
FME-P	Prolongation
FME-N	N
FME-FSMA	FSMA
FME-BNC	BNC
FME-TNC	TNC
FME-UHF	UHF
FME-MUHF	Mini-UHF
FME-EMUHF	Elbow-MUHF
FME-EBNC	Elbow-BNC

FME-ETNC	Elbow-TNC
FME-SMA	SMA

For further information about other types of FME-cables and FME-connectors, please compare the cable and connector data sheets under accessories in our catalogue.

TYPICAL SWR CURVES

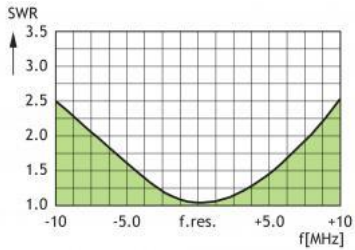

TYPICAL RADIATION PATTERN (E-PLANE)

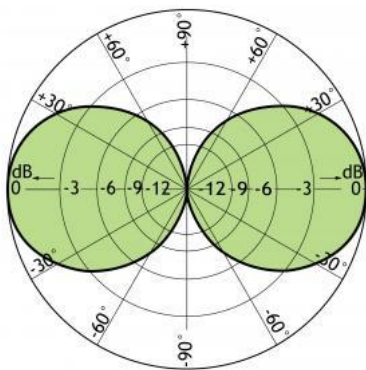



NTA 3E-SHT

Short Active three-frequency NAVTEX Receiving Antenna

- Specially designed for the three NAVTEX frequencies 490 kHz, 518 kHz and 4209.5 kHz.
- Built-in low-noise amplifier providing excellent impedance matching to the 50 ohm download cable.

- Special band-pass filter based tuning circuitry to optimize the antenna for the NAVTEX frequencies and protect from possible interference from e.g. medium wave broadcast radio signals.
- RF ground internally AC-coupled to mounting bracket preventing electrolytic corrosion.
- Sturdy design to withstand the roughest weather and climate conditions.
- Simple mounting using the 1" revolving nut system.
- Wide variety of accessory mounting brackets available.
- Junction kit for easy connection to receiver and DC power supply available (to be ordered separately).

ORDERING DESIGNATIONS

TYPE	PRODUCT NO.
NTA 3E-SHT	110000235
BCL 1-KA Junction kit	110000003

SPECIFICATIONS

ELETRICAL	
MODEL	NTA 3E-SHT
ANTENNA TYPE	Active E-field narrow-band three-frequency NAVTEX antenna
FREQUENCY	490 kHz, 518 kHz and 4209.5 kHz
IMPEDANCE	Nom. 50 Ω
SWR	≤ 1.5
SUPPLY VOLTAGE / CURRENT	9 to 15 VDC / 20 mA
MECHANICAL	
TEMP. RANGE	-30°C → +60°C
CONNECTOR	N-female
WIND SURFACE	Approx. 0.013 m ²
WIND LOAD	Approx. 17 N @ 160 km/h
COLOUR	Marine white
MATERIALS	Shroud: Polyurethane-coated glass fibre

	Mounting bracket: Chromed brass
TOTAL HEIGHT	Approx. 530 mm
DIA. IN TOP END	21 mm
DIA. IN BOTTOM END	23 mm
WEIGHT	Approx. 350 g
MOUNTING	On 1" RG (G1"-11) threaded water pipe or on optional mounting brackets (see below)

ACCESSORIES

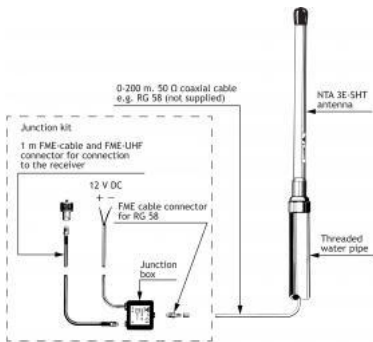

ACCESSORIES (to be ordered separately)

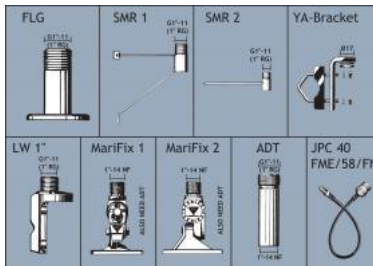



Marifix 1 / Marifix 2 / ADT / MBS

Marine 4-Way Swivel Ratchet Mounts, Adapter Tube, Marifix Barrel Spring

MariFix1 / MariFix 2

- 4-way swivel ratchet mounts
- For deck, cabin roof or bulkhead mounting
- Fast-release locking mechanisms allows antenna to fold down
- Available in chromed brass or UV resistant polycarbonate

ADT

- Use the ADT adapting tube or MBS to fix antennas (based on mounting with revolving nut on 1" threaded water pipe) on the MariFix 1 and MariFix 2.

MBS

- The MBS (MariFix Barrel Spring) is designed to move and flex with the antenna to prevent damage from strong winds or low hanging objects

DESCRIPTION



MariFix 1

MariFix 2

ADT

MBS

MariFix 1 / MariFix 2

- The 4-way swivel ratchet mounts permit mounting of marine antennas on slanted decks, cabin roofs or bulkheads
- Vibration secure and fast-release locking mechanisms make tilting and complete lay-down of the antenna quick and easy
- The MariFix 1 is made of chromed brass
- The MariFix 2 is made of UV resistant polycarbonate
- Max. antenna height with the MariFix 1 and MariFix 2 mounts
 - MariFix 1: Max. 4.5 m
 - MariFix 2: Max. 2.0 m
- To prevent damage it is recommended to lay down long antenna elements when the vessel is operated at high speed
- The Marifix mounts are delivered with stainless steel screws/bolts, spring washers, and bolts along with a gasket

ADT

- Use the ADT adapting tube or MBS to fix antennas (based on mounting with revolving nut on 1" threaded water pipe) on the MariFix 1 and MariFix 2

MBS

- The MBS is designed to move and flex with the antenna to prevent damage from strong winds or low hanging objects
- The barrel spring is made from stainless steel for long lasting finish.
- Max. antenna height: 1.2 m

ORDERING DESIGNATIONS

TYPE	DESCRIPTION	PRODUCT NO.
MariFix 1	Heavy-duty, chromed brass ratchet mount for deck or bulkhead mounting.	110000050
MariFix 2	Medium-duty, polycarbonate ratchet mount for deck or bulkhead mounting.	110000048
ADT	Adapting tube.	110000049
MBS	MariFix Barrel Spring	110000323

SPECIFICATIONS

MODEL	MariFix 1	MariFix 2	ADT	MBS
APPLICATION	Deck or bulkhead mount for marine antennas	Deck or bulkhead mount for marine antennas	Adapting tube	Adapting spring
MATERIAL	Chromed brass	Polycarbonate	Chromed brass	Chromed brass
COLOUR	Bright chrome	Marine white	Bright chrome	Bright chrome
THREAD TYPE	1"-14 NF	1"-14 NF	Top (ext.): G1"-11 (1" RG) Bottom (int.): 1"-14 NF	Top (ext.): G1"-11 (1" RG) Bottom (int.): 1"-14 NF
MAX. ANTENNA HEIGHT	4.5 m	2.0 m	-	-
DIMENSIONS (W x D x H)	96 x 56 x 129 mm	104 x 66 x 130 mm	ø33 x 110 mm	ø51 x 131 mm
WEIGHT	Approx. 0.81 kg	Approx. 0.22 kg	Approx. 0.19 kg	Approx. 0.7 kg

MOUNTING DETAILS

MariFix 1

MariFix 2

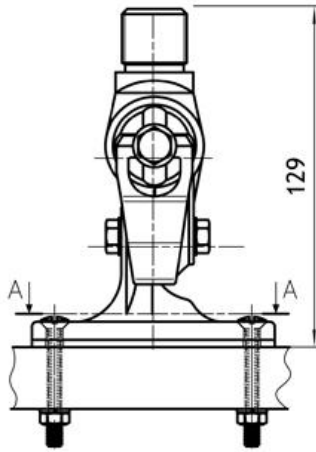

Section A-A

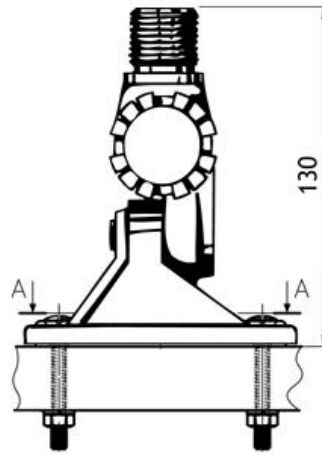
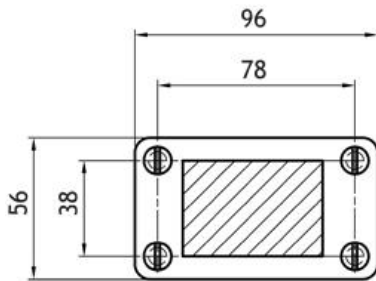

Section A-A

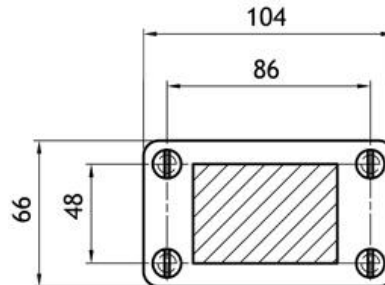

ADT

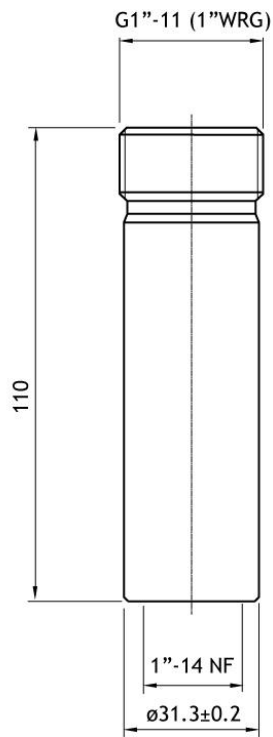

MBS

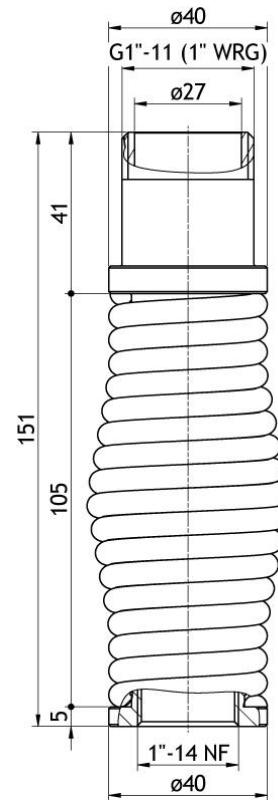

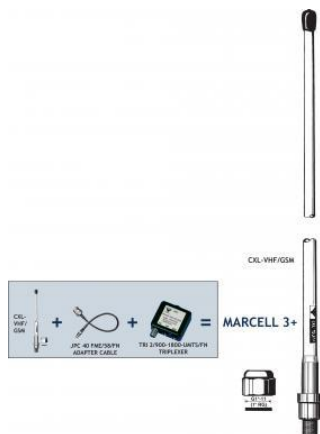

MARCELL 3+

3-Band Marine Antenna System Covering FM-Radio, Maritime VHF and 900 MHz Cellular (EGSM/NMT-900)

- Complete package for FM-Radio, maritime VHF and 900 MHz cellular
 - all you need extra is a download cable.
- The antenna is mounted using the 1" revolving nut system and easily replaces the existing antenna - the download cable may be reused.

DESCRIPTION

- The system comprises:
 - CXL-VHF/GSM dual-frequency antenna,
 - TRI 2/900-1800-UMTS/FM splitting filter to connect the FM-Radio marine VHF radio and a mobile telephone to one antenna,
 - JPC 40 FME/58/FN jumper cable.
- One antenna - three bands:
 - Covers FM-Radio (87.5 - 108 MHz), maritime VHF (155 - 162 MHz) and 900 MHz cellular (890 - 960 MHz),
 - 0 dBd on maritime VHF (155 - 162 MHz) and EGSM (880 - 960 MHz), Exploits the mast head space optimally.
 - Eliminates interference problems between two closely mounted antennas.
 - Only one download cable necessary.
- Mount the antenna as high as possible and unobstructed by metal objects.
- Wide range of accessory mounting brackets available (see next page).

ORDERING DESIGNATIONS

TYPE NO.	PRODUCT NO.
MARCELL 3+	110000129

SPECIFICATIONS

ELETRICAL	
MODEL	MARCELL 3+
ANTENNA TYPE	Triple-band marine antenna
ANTENNA FREQUENCY	FM Radio: 87.5 - 108 MHz Maritime VHF: 155 - 162 MHz EGSM: 890 - 960 MHz
FILTER FREQUENCY	VHF Radio: 144 - 175 MHz (COM1) Mobile telephone: 880 - 2200 MHz (COM2) Car radio: 0 - 108 MHz (RADIO)
IMPEDANCE	Nom. 50 Ω
RADIATION	Omnidirectional
POLARISATION	Vertical
ANTENNA GAIN	2 dBi 0 dBd on both VHF and EGSM

ANTENNA SWR	TX: ≤ 1.5 RX: ≤ 2.5
FILTER INSERTION LOSS	0 - 108 MHz: ≤ 1.0 dB 144 - 175 MHz: ≤ 0.8 dB 880 MHz - 2.2 GHz: ≤ 0.7 dB
FILTER ISOLATION	COM1 to COM2: ≥ 40 dB COM1 to car radio: ≥ 35 dB COM2 to car radio: ≥ 45 dB
MAX. POWER	35 W on each filter port 10 W on 880 - 2200 MHz filter port (100 W for the antenna)
ANTISTATIC PROTECTION	All metal parts of the antenna are DC-grounded (shows a DC-short at the connector)
MECHANICAL	
TEMP. RANGE	-30°C → +70°C
CONNECTOR	Antenna: N-female Filter: COM1, COM2, Antenna: FME Car radio: CRC-connector (M10 x 0.75) Jumper cable: FME-female and N-female
ADAPTOR CABLE	40 cm RG 58
DOWNLEAD CABLE	Not supplied. Min. RG 213 recommended.
WIND SURFACE	Approx. 0.013 m ²
WIND LOAD	Approx. 15 N @ 150 km/h
COLOUR	Marine white
ANTENNA MATERIALS	Shroud: Polyurethane coated glass fibre Mounting bracket: Chromed brass
ANTENNA HEIGHT	Approx. 1.1 m
DIA. IN TOP END	8 mm
DIA. IN BOTTOM END	16 mm
FILTER DIMENSIONS (W x H x D)	50 x 21 x 50 mm
ANTENNA WEIGHT	Approx. 400 g
MOUNTING	On 1" RG (G1"-11) threaded pipe or on optional mounting brackets (see below).





FME-SYSTEM ACCESSORIES

FME-CABLES		FME-CONNECTORS	
TYPE	PRODUCT NO.	TYPE	PRODUCT NO.
1 m FME	130000437	FME-FME	130000583
2 m FME	130000447	FME-P (Prolongation)	130000565
3 m FME	130000457	FME-N	130000571
4 m FME	130000466	FME-FSMA (Female-SMA)	130000578
5 m FME	130000474	FME-BNC	130000566
6 m FME	130000483	FME-TNC	130000569
4 m FME-white	110000064	FME-UHF	130000572
6 m FME-white	110000066	FME-MUHF (Mini-UHF)	130000573
12 m FME-white	110000068	FME-EMUHF (Elbow-MUHF)	130000582
18 m FME-white	110000069	FME-EBNC (Elbow-BNC)	130000580
For further information about other types of FME-cables and FME-connectors, please compare the cable and connector data sheets under accessories in our catalogue.		FME-ETNC (Elbow-TNC)	130000581
		FME-SMA	130000577

FILTER RESPONSE

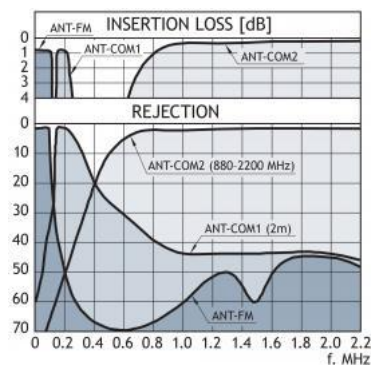

MOUNTING ACCESSORIES

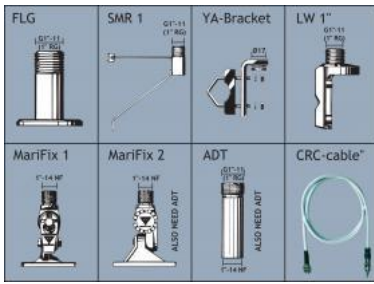

(To be ordered separately)

TYPICAL RADIATION PATTERN (E-PLANE)

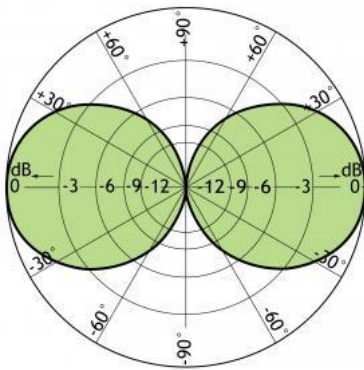

TYPICAL RADIATION PATTERN (H-PLANE)

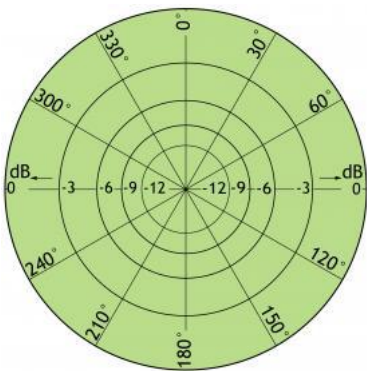

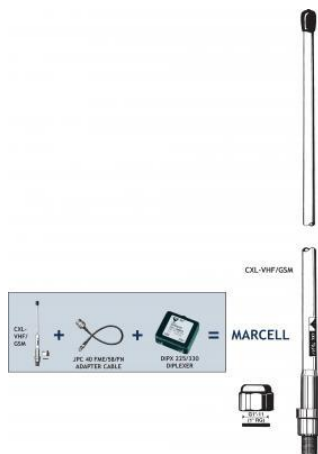

MARCELL

2-Band Marine Antenna System Covering Maritime VHF and 900 MHz Cellular (GSM/NMT-900)

- Complete package for maritime VHF and 900 MHz cellular all you need extra is a download cable.
- The antenna is mounted using the 1" revolving nut system and easily replaces the existing antenna - the download cable may be reused.

DESCRIPTION

- The system comprises:
 - CXL-VHF/GSM dual-frequency antenna,
 - DIPX 225/330 splitting filter to connect the two radio telephones to one antenna,
 - JPC 40 FME/58/FN jumper cable.
- One antenna - two bands
 - Covers maritime VHF (155 - 162 MHz) and 900 MHz cellular (890 - 960 MHz).
 - 0 dBd on both bands.
 - Exploits the mast head space optimally.
 - Eliminates interference problems between two closely mounted antennas.
 - Only one download cable necessary.
- Mount the antenna as high as possible and unobstructed by metal objects.
- Wide range of accessory mounting brackets available (see next page).

ORDERING DESIGNATIONS

TYPE NO.	PRODUCT NO.
MARCELL	110000128

SPECIFICATIONS

ELETRICAL	
MODEL	MARCELL
ANTENNA TYPE	Dual-frequency coaxial antenna
ANTENNA FREQUENCY	Maritime VHF: 155 - 162 MHz GSM/NMT-900: 890 - 960 MHz
FILTER FREQUENCY	Low port: 0 - 255 MHz High port: 330 - 1300 MHz
IMPEDANCE	Nom. 50 Ω
RADIATION	Omnidirectional
POLARISATION	Vertical
ANTENNA GAIN	2 dBi 0 dBd on both bands
ANTENNA SWR	TX: ≤ 1.5

	RX: ≤ 2.5
FILTER INSERTION LOSS	0 - 225 MHz: ≤ 0.5 dB 330 - 1300 MHz: ≤ 0.5 dB
FILTER ISOLATION	Low to high port: ≥ 45 dB
MAX. POWER	35 W on each filter port (100 W for the antenna)
ANTISTATIC PROTECTION	All metal parts of the antenna are DC-grounded (shows a DC-short at the connector)
MECHANICAL	
TEMP. RANGE	-30°C → +70°C
CONNECTOR	Antenna: N-female Filter: FME-male (all ports) Jumper cable: FME-female and N-female
JUMPER CABLE	40 cm RG 58
DOWNLEAD CABLE	Not supplied. Min. RG 213 recommended.
WIND SURFACE	Approx. 0.013 m ²
WIND LOAD	Approx. 15 N @ 150 km/h
COLOUR	Marine white
ANTENNA MATERIALS	Shroud: Polyurethane coated glass fibre Mounting bracket: Chromed brass
ANTENNA HEIGHT	Approx. 1.1 m
DIA. IN TOP END	8 mm
DIA. IN BOTTOM END	16 mm
FILTER DIMENSIONS (W x H x D)	50 x 21 x 50 mm
ANTENNA WEIGHT	Approx. 400 g
MOUNTING	On 1" RG (G1"-11) threaded pipe or on optional mounting brackets (see below).

FILTER RESPONSE

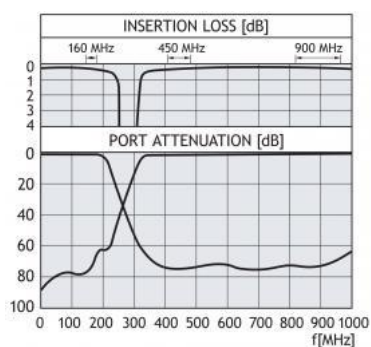

TYPICAL RADIATION PATTERN (E-PLANE)

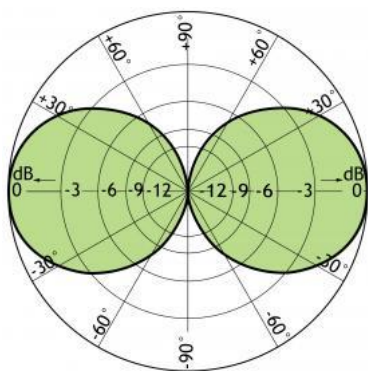

TYPICAL RADIATION PATTERN (H-PLANE)

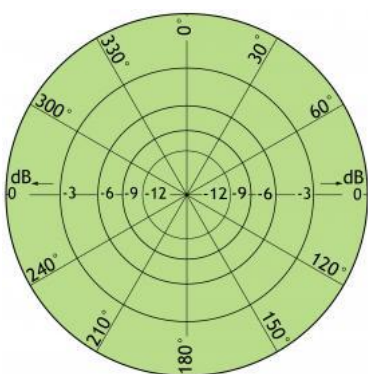

FME-SYSTEM ACCESSORIES

FME-CABLES		FME-CONNECTORS	
TYPE	PRODUCT NO.	TYPE	PRODUCT NO.
1 m FME	130000437	FME-FME	130000583
2 m FME	130000447	FME-P (Prolongation)	130000565
3 m FME	130000457	FME-N	130000571
4 m FME	130000466	FME-FSMA (Female-SMA)	130000578
5 m FME	130000474	FME-BNC	130000566
6 m FME	130000483	FME-TNC	130000569
4 m FME-white	110000064	FME-UHF	130000572
6 m FME-white	110000066	FME-MUHF (Mini-UHF)	130000573
12 m FME-white	110000068	FME-EMUHF (Elbow-MUHF)	130000582
18 m FME-white	110000069	FME-EBNC (Elbow-BNC)	130000580

For further information about other types of FME-cables and FME-connectors, please compare the cable and connector data sheets under accessories in our catalogue.



FME-ETNC (Elbow-TNC)	130000581
FME-SMA	130000577

MOUNTING ACCESSORIES

(To be ordered separately)



MA DAB SC

Base Station and Marine DAB Antenna with Low Weight and Wind Load

- The dimensions of this base station, marine and receiving DAB (Digital Audio Broadcast) antenna are kept as small as possible to reduce weight, wind load and cost.
 - Despite the small dimensions the efficiency is very high.

DESCRIPTION

- The tapered $\frac{1}{2} \lambda$ stainless steel radiator together with the chromed brass housing and stainless steel corner bracket constitute an antenna tough and ready to cope with the corrosive environment at the masthead.
- The end-fed dipole principle makes the antenna independent of ground-plane, radials or other auxiliary arrangements.
- The antenna whip should not be mounted parallel or near other metal parts, such as windex, supporting wires etc. Free mounting and as high as possible is preferable, otherwise the SWR and the radiation diagram will be influenced.

ORDERING DESIGNATIONS

TYPE	PRODUCT NO.
MA DAB SC	100000085

SPECIFICATIONS

ELECTRICAL	
MODEL	MA DAB SC
ANTENNA TYPE	$\frac{1}{2} \lambda$ dipole, end-fed
FREQUENCY	223 - 240 MHz
IMPEDANCE	Nom. 50 Ω
POLARIZATION	Vertical
GAIN	2 dBi 0 dBd
BANDWIDTH	17 MHz
SWR	

MAX. POWER	25 W
ANTISTATIC PROTECTION	All metal parts DC-grounded (Connector shows a DC-short)
MECHANICAL	
TEMP. RANGE	-30° C → +70° C
CONNECTOR	UHF-female
WIND SURFACE	0.0076 m ²
WIND LOAD	9.6 N @ 160 km/h
COLOUR	Bright chromed
MATERIALS	Shroud : Stainless steel Housing: Chromed brass
TOTAL HEIGHT	Approx. 800 mm
WEIGHT	Approx. 265 g
MOUNTING	With fast screws, rivets or binders

TYPICAL GAIN AND SWR CURVES

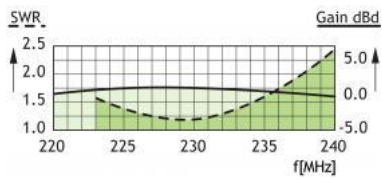

TYPICAL RADIATION PATTERN (E-PLANE)

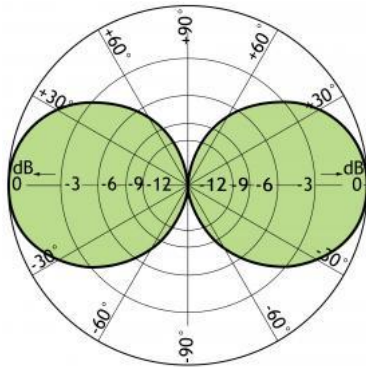

TYPICAL RADIATION PATTERN (H-PLANE)

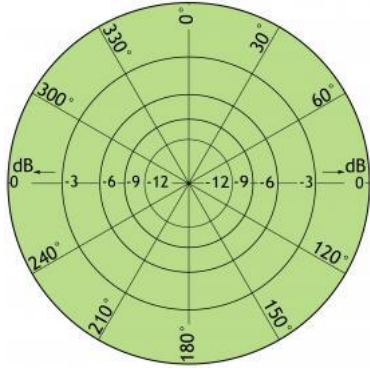

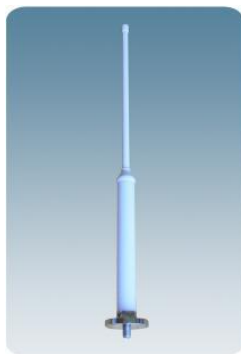

MA 70/GPS 4/...

Dual Band Antenna for the UHF band e.g. TETRA, CDMA, ICE, and GPS.

- This active antenna has been designed for use on the UHF band e.g. TETRA, CDMA, ICE, and GPS.
- The antenna consists of a high-performance glass fibre- encapsulated antenna element and an active GPS antenna. The latter is built into the bottom part of the antenna together with a diplex filter. Only one down lead cable is therefore necessary.

DESCRIPTION

- The antenna element is a $1/2 \lambda$ antenna for the UHF band frequency range within 380 - 467 MHz.
- The GPS antenna has a full hemispherical coverage and a built-in high-gain, low-noise amplifier.
- The necessary supply voltage (5 V DC) for the amplifier is delivered through the down lead coaxial cable. Up to 30 m of RG 214/U coaxial cable can be used between the antenna and the receiver/transceiver.
- By careful choice of materials, the MA 70/GPS 4/... is designed to withstand the roughest of climate conditions, ensuring many years of trouble-free service.

ORDERING DESIGNATIONS

TYPE	PRODUCT NO.	FREQUENCY
MA 70/GPS 4/TETRA-l	110000200	380 - 400 MHz
MA 70/GPS 4/TETRA-h	110000201	410 - 430 MHz
MA 70/GPS 4/CDMA	110000202	453 - 467 MHz
MA 70/GPS 4/ice.net	110000223	453 - 467 MHz
MA 70/GPS 4/NET 1	110000224	453 - 467 MHz
DM Mounting Kit	112000001	
SM-MAS	110000196	
DIPX 1000/1550 N-DC-H	200000749	
PRO-DIPX 1000/1550 N-DC-H	200000799	

SPECIFICATIONS

ELECTRICAL UHF	
MODEL	MA 70/GPS 4/...
ANTENNA TYPE	$1/2 \lambda$ antenna element
FREQUENCY	Models within 380 - 467 MHz
BANDWIDTH	5 % of freq. @ SWR \leq 1.5
IMPEDANCE	Nom. 50 Ω
POLARIZATION	Vertical

GAIN	Approx. 2 dBi 0 dBd
SWR	Typ. < 2.0
MAX. POWER	25 W
ELECTRICAL GPS	
ANTENNA TYPE	Quadrifilar Helix Active antenna
FREQUENCY	1575 MHz
IMPEDANCE	Nom. 50 Ω
POLARIZATION	Circular right-hand
COVERAGE	Hemispherical
GAIN (in axial direction)	> 32 dBi
CROSS POLARIZATION ATT	> 10 dB (typ.)
Built-in Amplifier	
GAIN	> 30 dB (typ.)
NOISE FIGURE	< 3 dB (typ.)
P _{1 dB}	Approx. +10 dBm
SWR (output)	≤ 2.0
SUPPLY VOLTAGE	5 ±0.5 V DC (3 V and 12 V respectively available on request)
SELECTIVITY	> 20 dB down @ ± 100 MHz
CURRENT CONSUMPTION	Approx. 44 mA
MECHANICAL (for the MA 70/GPS 4/...)	
TEMP. RANGE	-30° C → + 70° C
CONNECTOR	N-female
WIND SURFACE	Approx. 0.018 m ²
WIND LOAD	Approx. 23 N @ 160 km/h
COLOUR	Marine white
MATERIALS	Shroud : Polyurethane-coated glass fibre Flange : Chromed brass
TOTAL HEIGHT	Approx. 730 mm
WEIGHT	Approx. 900 g
MOUNTING	Standard mounting on plane surface. Deck mounting by means of DM Mounting Kit (optional extra). Mounting on 30-44 mm mast tube by means of SM-MAS (optional extra)



Standard Mounting Kit included



DM Mounting Kit for Deck Mount to be ordered separately

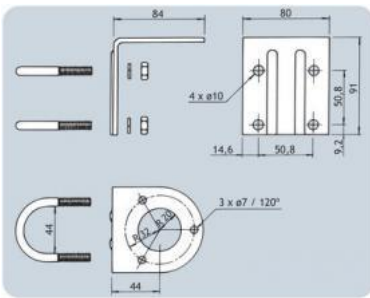

SM-MAS Mounting Kit for Side Mount and Mast Mount to be ordered separately

MOUNTING ON FLAT SURFACES

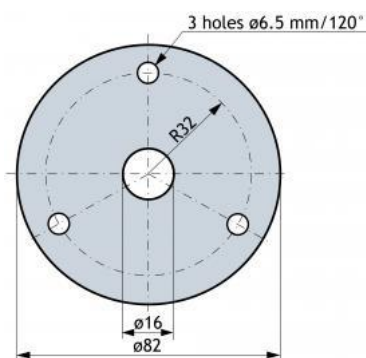

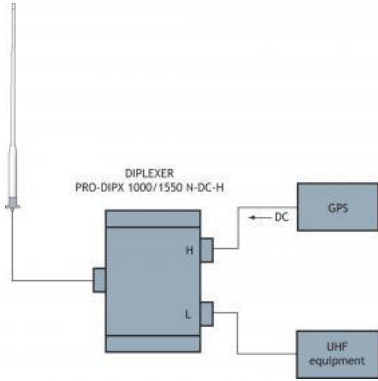

Alternatively, filter type DIPLEXER DIPX 1000/1550 N-DC-H can be used. Either filter to be ordered separately

RADIATION PATTERN FOR THE UHF BAND

TYPICAL RADIATION PATTERN (E-PLANE)

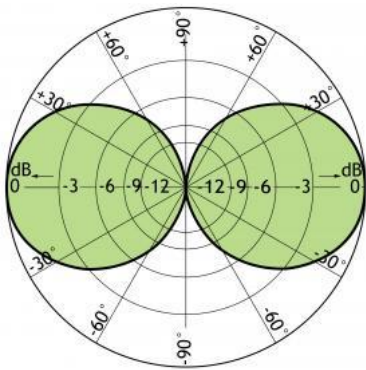

TYPICAL RADIATION PATTERN (H-PLANE)

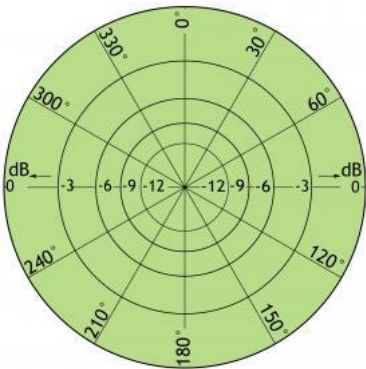

TYPICAL GAIN AND SWR CURVES

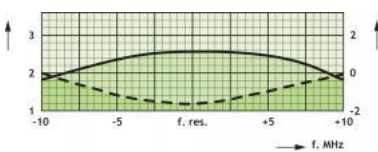

VERTICAL RADIATION PATTERN

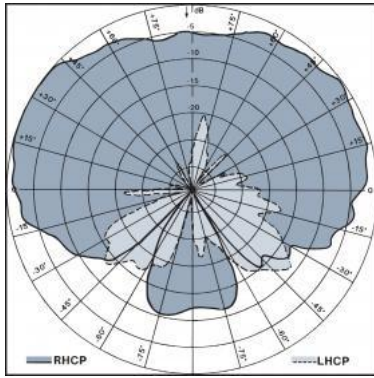

TYPICAL RESPONSE CURVES AND RADIATION PATTERN FOR THE GPS-PART (1575 MHz)

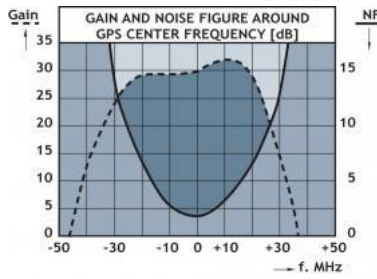
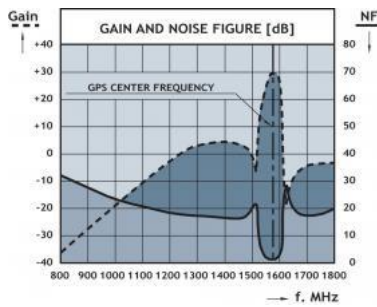



MA 2-1 SC-SHT

Marine VHF Antenna with reduced height

- The efficiency is very high despite the small dimensions and the antenna is fully capable of handling up to 50 W of output power.
- The tapered, reduced, encapsulated $\frac{1}{2} \lambda$ copper wire radiator together with the chrome brass housing and stainless steel corner bracket constitute an antenna tough and ready to cope with the corrosive environment at the masthead or other places.

DESCRIPTION

- The end-fed dipole principle makes the antenna independent of ground-plane, radials or other auxiliary arrangements.
- The antenna whip should not be mounted parallel or near to other metal parts, such as windex, supporting wires etc. Free mounting and as high as possible is preferable, otherwise the SWR and the radiation diagram will be influenced.

ORDERING DESIGNATIONS

TYPE	PRODUCT NO.
MA 2-1 SC-SHT	110000236

SPECIFICATIONS

ELECTRICAL	
MODEL	MA 2-1 SC-SHT
ANTENNA TYPE	Reduced $\frac{1}{2} \lambda$ dipole, end-fed
FREQUENCY	156 - 162 MHz
IMPEDANCE	Nom. 50 Ω
POLARIZATION	Vertical
GAIN	-1 dBi -3 dBd
BANDWIDTH	6 MHz \leq SWR 2
SWR	< 2.0
MAX. POWER	50 W
MECHANICAL	
TEMP. RANGE	-30° C to +70° C
CONNECTOR	UHF-female
WIND SURFACE	0.0094 m ²
WIND LOAD	10.4 N @ 150 km/h
COLOUR	Bright chrome White

MATERIALS	Whip : Glass fibre whip with copper wire winding, polyethylene-covered. Bright-chrome brass. Housing: Chrome brass
TOTAL HEIGHT	Approx. 0.55 m
WEIGHT	Approx. 400 g
MOUNTING	With screws, rivets or binder

TYPICAL GAIN AND SWR CURVE

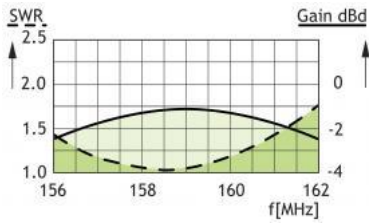

“YA” MOUNTING BRACKET DIMENSIONS

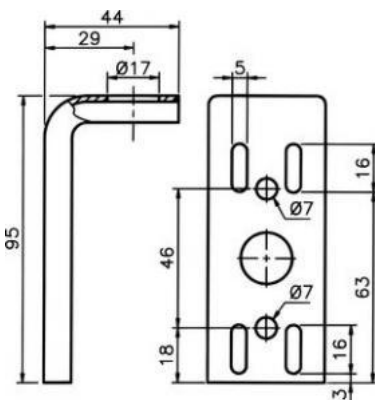

TYPICAL RADIATION PATTERN (E-PLANE)

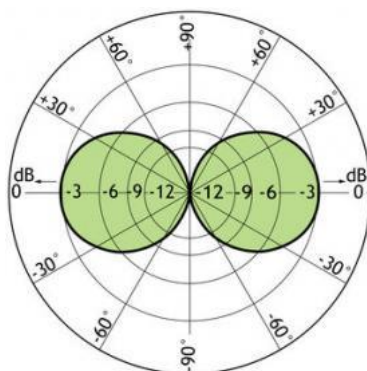

TYPICAL RADIATION PATTERN (H-PLANE)





MA 2-1 SC

Marine VHF Antenna with Low Weight and Wind Load for Masthead Mounting

- This marine VHF antenna is designed especially for mounting at the masthead of sailboats. The dimensions have been kept as small as possible to reduce weight, wind load and cost.
- Despite the small dimensions the efficiency is very high, and the antenna is fully capable of handling the full 50 W of output power from typical marine VHF transmitters.

DESCRIPTION

- The tapered $\frac{1}{2} \lambda$ stainless steel radiator together with the chromed brass housing and stainless steel corner bracket constitute an antenna tough and ready to cope with the corrosive environment at the masthead.
- The end-fed dipole principle makes the antenna independent of ground-plane, radials or other auxiliary arrangements.
- The antenna whip should not be mounted parallel or near to other metal parts, such as windex, supporting wires etc. Free mounting and as high as possible is preferable, otherwise the SWR and the radiation diagram will be influenced.

ORDERING DESIGNATIONS

TYPE	PRODUCT NO.
MA 2-1 SC	110000133

SPECIFICATIONS

ELECTRICAL	
MODEL	MA 2-1 SC
ANTENNA TYPE	$\frac{1}{2} \lambda$ dipole, end-fed
FREQUENCY	156 - 162 MHz
IMPEDANCE	Nom. 50 Ω
POLARIZATION	Vertical
GAIN	2 dBi 0 dBd
BANDWIDTH	6 MHz
SWR	< 2.0
MAX. POWER	50 W
MECHANICAL	
TEMP. RANGE	-30° C → +70° C
CONNECTOR	UHF-female
WIND SURFACE	0.0076 m ²

WIND LOAD	8.9 N @ 150 km/h
COLOUR	Bright chrome White
MATERIALS	Whip : Stainlesssteel Housing: Chromed brass
TOTAL HEIGHT	Approx. 1.08 m
WEIGHT	Approx. 265 g
MOUNTING	With screws, rivets or binder

TYPICAL GAIN AND SWR CURVE

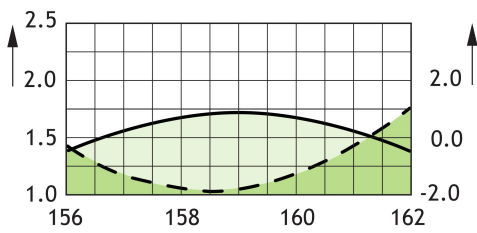

“YA” MOUNTING BRACKET DIMENSIONS

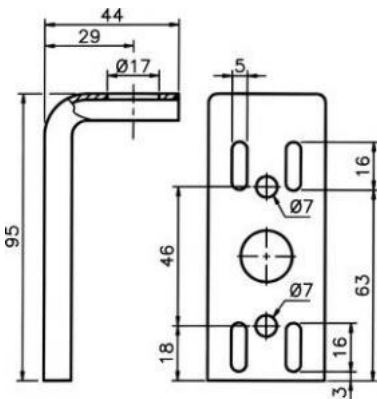

TYPICAL RADIATION PATTERN (E-PLANE)

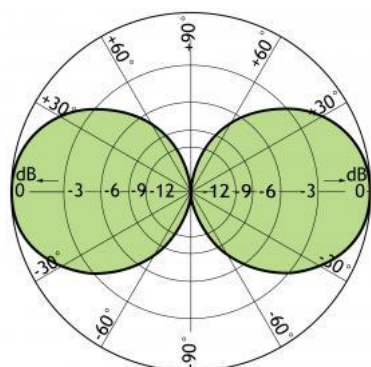

TYPICAL RADIATION PATTERN (H-PLANE)

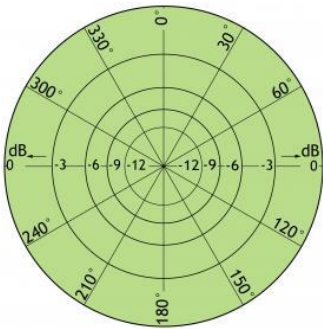



MA 2-1 MR

Marine VHF Antenna with Low Wind Load

- This marine VHF antenna is designed especially for mounting at the masthead of sailboats. The dimensions have been kept as small as possible to reduce weight, wind load and cost.
- Despite the small dimensions the efficiency is very high, and the antenna is fully capable of handling the full 50 W of output power from typical marine VHF transmitters.

DESCRIPTION

- The tapered $\frac{1}{2} \lambda$ stainless steel radiator together with the chromed brass housing and stainless steel corner bracket constitute an antenna tough and ready to cope with the corrosive environment at the masthead.
- The end-fed dipole principle makes the antenna independent of ground-plane, radials or other auxiliary arrangements.
- The antenna whip should not be mounted parallel or near to other metal parts, such as windex, supporting wires etc. Free mounting and as high as possible is preferable, otherwise the SWR and the radiation diagram will be influenced.

ORDERING DESIGNATIONS

TYPE NO.	PRODUCT NO.
MA 2-1 MR	110000131

SPECIFICATIONS

ELECTRICAL	
MODEL	MA 2-1 MR
ANTENNA TYPE	$\frac{1}{2} \lambda$ dipole, end-fed
FREQUENCY	156 - 162 MHz
IMPEDANCE	Nom. 50 Ω
POLARISATION	Vertical
GAIN	2 dBi 0 dBd
BANDWIDTH	6 MHz
SWR	
MAX. POWER	200 W
MECHANICAL	
TEMP. RANGE	-30° C \rightarrow +70° C
CONNECTOR	UHF-female
WIND SURFACE	0.0076 m ²

WIND LOAD	8.5 N @ 150 km/h
COLOUR	Marine white
MATERIALS	Shroud : Stainless steel Housing: Glassfibre and chromed brass
TOTAL HEIGHT	Approx. 1.08 m
WEIGHT	Approx. 480 g
MOUNTING	With fast screws, rivets or binders

TYPICAL GAIN AND SWR CURVE

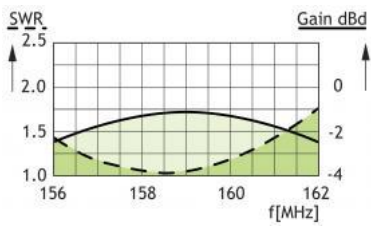

TYPICAL RADIATION PATTERN (E-PLANE)

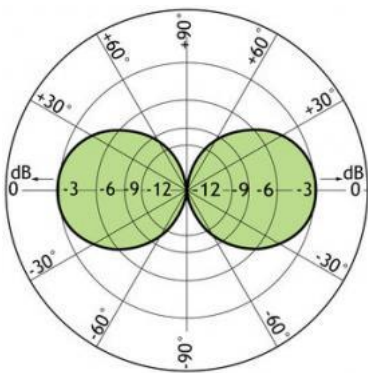

TYPICAL RADIATION PATTERN (H-PLANE)

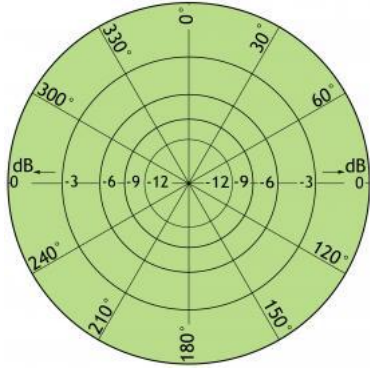



GPS 4/...

Active Receiving Antenna for the 1575 MHz NAVSTAR GPS Satellite Navigational System

- Full hemispherical coverage due to quadrifilar helix antenna element.
- Built-in high gain, low noise amplifier.
- Input filter for thorough RF-overload protection.
- Right-hand circular polarization (RHCP).

Description

- High rejection of cross-polarized reflections prevents fading caused by multipath propagation.
- 5 V supply voltage (3 V respectively 12 V available on request).
- DC supply via RF-connector.
- EMC tested to IEC 801 and IEC 255.
- Total design carried out to make the antenna withstand tough environments.
- Comprehensive range of accessory mounting brackets available.
- Colour opportunities:
 - White (Standard)
 - Black
 - Sand

ORDERING DESIGNATIONS

TYPE	PRODUCT NO.	SUPPLY VOLTAGE	TYPE	PRODUCT NO.
GPS 4	112000017	5 V DC (4.5 - 5.5 V)	GPS 4-S	112000066
GPS 4/3 V	112000015	3 V DC (3 - 3.5 V)	GPS 4/3 V-S	112000068
GPS 4/12 V	112000016	12 V DC (9 - 15 V)	GPS 4/12 V-S	112000070
GPS 4-B	112000065	5 V DC (4.5 - 5.5 V)	GPS 4/5 V-TNC	112000014
GPS 4/3 V-B	112000067	3 V DC (3 - 3.5 V)	GPS 4/3 V-TNC	112000010
GPS 4/12 V-B	112000069	12 V DC (9 - 15 V)	GPS 4/12 V-TNC	112000012

SPECIFICATIONS

ELECTRICAL General Specifications	
MODEL	GPS 4/...
ANTENNA TYPE	Quadrifilar helix active antenna
FREQUENCY	1575 MHz
IMPEDANCE	Nom. 50 Ω
POLARIZATION	Circular right-hand

COVERAGE	Hemispherical
GAIN (in axial direction)	> 32 dBi
CROSSPOLARIZATION ATT.	> 10 dB
SELECTIVITY	> 20 dB down @ ± 100 MHz
Built-in Amplifier	
GAIN	> 30 dB
NOISE FIGURE	< 3 dB (incl. input filter). Typ. approx. 3 dB
1 dB COMPRESSION POINT	> 10 dBm
OUT OF BAND ATTENUATION	0.03 - 1 GHz : > 40 dB down 2 - 10 GHz : > 40 dB down
SWR (output)	< 2.0
SUPPLY VOLTAGE	GPS 4: 5 ± 0.5 V DC GPS 4/3 V: 3-3.5 V DC GPS 4/12V: 9-15 V DC
CURRENT CONSUMPTION	Approx. 44 mA
EMC	Full protection (IEC 801, IEC 255)
MECHANICAL	
MATERIALS	Antenna dome: Weather-resistant low-loss plastic
ANTENNA COLOUR	Marine white, black or sand
INSULATION	Connector ground terminal galvanically insulated from the mounting hardware
WIND SURFACE	Approx. 0.0072 m ² / 0.08 ft ²
MAX. WIND SPEED	200 km/h / 124.27 mph.
WIND LOAD	Approx. 9.6 N @ 150 km/h / 93.21 mph.
CONNECTOR	FME-male (pin) or TNC-female
SUGGESTED DOWNLEAD CABLE	< 10 m: RG 58 10 - 30 m: RG 213
TOTAL HEIGHT	Approx. 23 cm / 9.06 in.
ANTENNA DIA.	33 mm / 1.30 in.
WEIGHT	Approx. 150 g / 0.33 lb.
MOUNTING	Vertical on 1" water pipe or on PROCOM 1" mounting brackets (see accessories below)
ENVIRONMENTAL	
TEMP. RANGE	-50° C → +70° C
IP-RATING	IP-56 (IP-66 on request)



ACCESSORIES

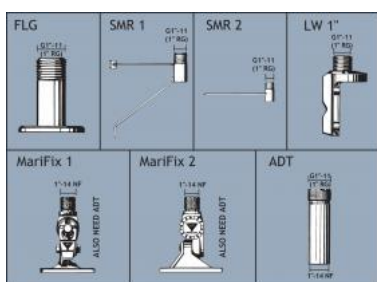

FME-SYSTEM ACCESSORIES

FME-CABLES	
TYPE	PRODUCT NO.
1 m FME(f)	130000437
2 m FME(f)	130000447
3 m FME(f)	130000457
4 m FME(f)	130000466
5 m FME(f)	130000474
6 m FME(f)	130000483
4 m FME-white(f)	110000064
6 m FME-white(f)	110000066
12 m FME-white(f)	110000068
18 m FME-white(f)	110000069
FME-CONNECTORS	
TYPE	PRODUCT NO.
FME(f)-FME(f)	130000583
FME(m)-P(m) (Prolongation)	130000565
FME(m)-N(m)	130000571
FME(m)-FSMA (Female-SMA)	130000578

FME(m)-BNC(m)	130000566
FME(m)-TNC(m)	130000569
FME(m)-UHF(m)	130000572
FME(m)-MUHF(m) (Mini-UHF)	130000573
FME(m)-EMUHF(m) (Elbow-MUHF)	130000582

For further information about other types of FME-cables and FME-connectors, please compare the cable and connector data sheets under accessories in our catalogue.

VERTICAL RADIATION PATTERN

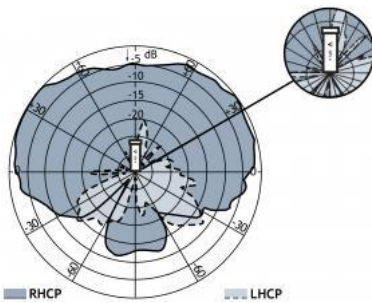

TYPICAL RESPONSE CURVES

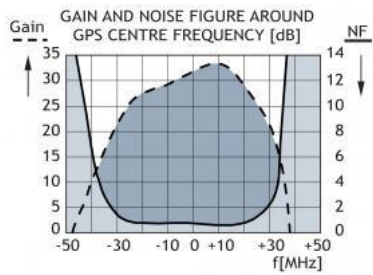
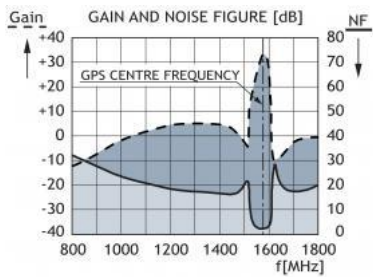



GPS 2000

Active Receiving Antenna for the 1575 MHz NAVSTAR GPS Satellite Navigational System for Maritime and Landmobile Use

- Flat-pack GPS-antenna for fixed installations.
- Full hemispherical coverage.
- Built-in high-gain, low-noise amplifier.

- Right-hand circular polarization (RHCP).
- Available in black or white, see model survey.
- 3 V or 5 V supply voltage (12 V available on request).
- DC supply via RF-connector.
- EMC tested to IEC 801 and IEC 255.
- Provided with FME (male), TNC (female) connector, or models with permanently attached 0.15 m cable with FME (male) connector, see model survey.
- Wide range of FME-accessories available.

ORDERING DESIGNATIONS

TYPE	COLOUR	PRODUCT NO.
FME CONNECTOR		
GPS 2000B-FME-5V	Black	112000026
GPS 2000B-FME-3V	Black	112000029
GPS 2000W-FME-5V	White	112000024
GPS 2000W-FME-3V	White	112000023
TNC CONNECTOR		
GPS 2000B-TNC-5V	Black	112000028
GPS 2000B-TNC-3V	Black	112000032
GPS 2000W-TNC-5V	White	112000027
GPS 2000W-TNC-3V	White	112000019
PERMANENTLY ATTACHED CABLE WITH MFME-CONNECTOR		
GPS 2000B-P0.15-5V	Black	112000072
GPS 2000B-P0.15-3V	Black	112000074
GPS 2000W-P0.15-5V	White	112000071
GPS 2000W-P0.15-3V	White	112000073

SPECIFICATIONS

ELECTRICAL General Specifications	
MODEL	GPS 2000

ANTENNA TYPE	Active patch antenna
FREQUENCY	1575 MHz
IMPEDANCE	Nom. 50 Ω
POLARIZATION	Circular right-hand
COVERAGE	Hemispherical
GAIN (in axial direction)	28 dBi (typ.)
CROSSPOLARIZATION ATT.	> 10 dB (typ.)
SELECTIVITY	> 45 dB down @ \pm 45 MHz
Built-in Amplifier	
GAIN	> 30 dB (typ.)
NOISE FIGURE	< 1 dB (typ.)
1 dB COMPRESSION POINT	Approx. +7 dBm
SWR (output)	< 2.0
SUPPLY VOLTAGE	5 \pm 0.5 VDC or 3 V \pm 0.3 VDC (12 V available on request)
CURRENT CONSUMPTION	Approx. 20 mA
MECHANICAL	
MOUNTING	14 mm / 0.55 in. dia. hole
MOUNTING THICKN.	0.7 \rightarrow 4.5 mm / 0.028 \rightarrow 0.18 in.
MATERIALS	Cu-nite brass, seawater resistant Lexan
COLOUR	Black or white, see ordering designations
TEMP. RANGE	-50° C \rightarrow +70° C
CONNECTOR	FME (male), TNC (female) or models with 0.15 m RG 316 permanently attached cable with FME (male) connector, see ordering designations
RECOMMENDED INSTALL. TORQUE	8.5 \pm 1 Nm
HEIGHT	16 mm / 0.63 in.
OUTER HEIGHT	26.5 mm / 1.04 in. total (FME) 38 mm / 1.50 in. total (TNC) 27 mm / 1.22 in. total for P0.15 models
WIDTH/LENGTH	\varnothing 55 mm / \varnothing 2.17 in.
WEIGHT	Approx. 120 g / 0.26 lb.

GPS 2000B-P0.15 and GPS 2000W-P0.15



FME-VERSION



TNC-VERSION



MODELS WITH PERMANENTLY ATTACHED CABLE



MOUNTING

The gasket should be entirely supported by the mounting plane.

Do not use sealer on rubber gasket or other places.

FME-SYSTEM ACCESSORIES

FME-CABLES	
TYPE	PRODUCT NO.
1 m FME	130000437
2 m FME	130000447
3 m FME	130000457
4 m FME	130000466
5 m FME	130000474
6 m FME	130000483
1 m FME-EFME	130000526
2 m FME-EFME	130000527
3 m FME-EFME	130000528
4 m FME-EFME	130000529

5 m FME-EFME	130000530
6 m FME-EFME	130000531
4 m FME-white	110000064
6 m FME-white	110000066
12 m FME-white	110000068
18 m FME-white	110000069
FME-CONNECTORS	
TYPE	PRODUCT NO.
FME-FME	130000583
FME-P (Prolongation)	130000565
FME-N	130000571
FME-FSMA (Female-SMA)	130000578
FME-BNC	130000566
FME-TNC	130000569
FME-UHF	130000572
FME-MUHF (Mini-UHF)	130000573
FME-EMUHF (Elbow-MUHF)	130000582
FME-EBNC (Elbow-BNC)	130000580
FME-ETNC (Elbow-TNC)	130000581
FME-SMA	130000577
MFME-MSMC	130001573

For further information about other types of FME-cables and FME-connectors, please compare the cable and connector data sheets under accessories.

VERTICAL RADIATION PATTERN

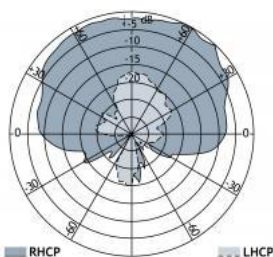

TYPICAL RESPONSE CURVES

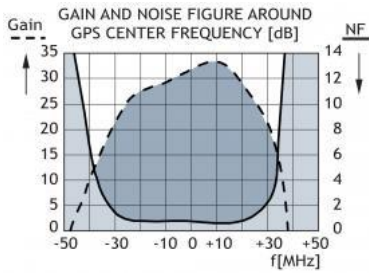
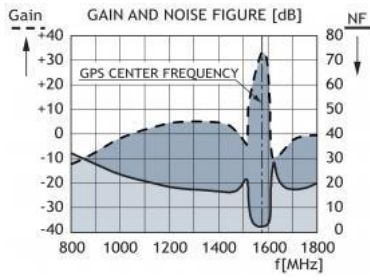

ACCESSORIES

Stainless steel angle bracket for fixation of GPS 2000... antennas. (To be ordered separately: MB 2000 clamp). Not recommended for GPS 2000...-P0.15 types.

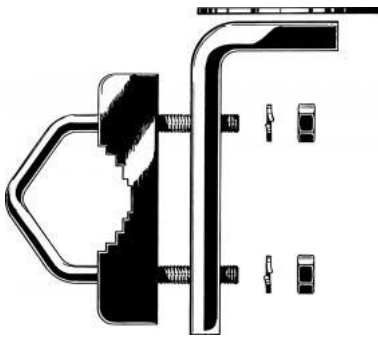



GPS 100 KT-FME

Active Receiving Antenna for the 1575 MHz NAVSTAR GPS Satellite Navigational System for Landmobile and Maritime Use

- Flat-pack GPS-antenna for temporary or fixed installations.
- Full hemispherical coverage.

Description

- Built-in high gain, low noise amplifier.
- Right-hand circular polarization (RHCP).
- Magnet mount - ideal for mounting on e.g. roof of car or vessel.
- 5 V supply voltage (3 V respectively 12 V available on request).
- DC supply via RF-connector.
- Permanently attached 5 m RG 174 coaxial cable terminated with FME (female) connector.
- Wide range of FME-accessories available.

Ordering designations

TYPE NO.	PRODUCT NO.
GPS 100 KT-FME	112000022

SPECIFICATIONS

ELECTRICAL General specifications	
MODEL	GPS 100 KT-FME
ANTENNA TYPE	Active patch antenna
FREQUENCY	1575 MHz (DCS)
IMPEDANCE	Nom. 50 Ω
POLARISATION	Circular right-hand
COVERAGE	Hemispherical
GAIN (in axial direction)	27 dBi (typ.)
CROSS-POLARISATION ATT.	> 10 dB (typ.)
SELECTIVITY	> 45 dB down at ± 45 MHz
BUILT-IN AMPLIFIER	
GAIN	> 26 dB (typ.)
NOISE FIGURE	≤ 3 dB (typ.)
SWR (output)	≤ 2.0
SUPPLY VOLTAGE	5 ± 0.5 VDC
CURRENT CONSUMPTION	Approx. 25 mA
MECHANICAL	

MATERIALS	Aluminium and ABS
ANTENNA COLOUR	Black
TEMP. RANGE	-35° C → +75° C
CONNECTOR	FME-female
CABLE	5 m RG 174
HEIGHT	15 mm
WIDTH/LENGTH	ø50 mm
WEIGHT	Approx. 130 g



Do not use sealer on rubber gasket or other places.

FME-SYSTEM ACCESSORIES

FME-CABLES	
LENGTH	TYPE NO.
1 m	1 m FME
2 m	2 m FME
3 m	3 m FME
4 m	4 m FME
5 m	5 m FME
6 m	6 m FME
4 m white	4 m FME-white
6 m white	6 m FME-white
12 m white	12 m FME-white
18 m white	18 m FME-white
FME-CONNECTORS	
CONNECTOR	ORDER NO.
FME-FME	FME-FME
Prolongation	FMEP
N	FME-N
FSMA	FME-FSMA
BNC	FME-BNC
TNC	FME.TNC
UHF	FME-UHF

Mini-UHF	FME-MUHF
Elbow-MUHF	FME-EMUHF
Elbow-BNC	FME-EBNC
Elbow-TNC	FME-ETNC
SMA	FME-SMA

For further information about other types of FME-cables please compare the cable data sheets under accessories in our catalogue.



GP 80 B/...

Broad-Banded, Antistatic Ground-Plane Antenna for the 80 MHz Band

- GP 80 B/... is a broad-banded ground-plane antenna of the triple-leg type.

Description

- The 80 MHz-band is covered by 3 models covering the following frequency segments: 66 - 78 MHz, 71 - 83 MHz and 76 - 88 MHz.
- Atmospheric discharges are immediately led to ground, as all metal parts are DC-connected. Consequently, the antenna shows a DC-short across the coaxial cable.
- GP 80 B/... is made from corrosion-resistant aluminium, which together with a special anodizing process gives this antenna a very long lifetime.

ORDERING DESIGNATIONS

TYPE	PRODUCT NO.	FREQUENCY
GP 80 B/l	100000065	66 - 78 MHz
GP 80 B/m	100000064	71 - 83 MHz
GP 80 B/h	100000063	76 - 88 MHz

SPECIFICATIONS

ELECTRICAL	
MODEL	GP 80 B/...
ANTENNA TYPE	$\frac{1}{4} \lambda$ ground-plane, broad-banded
FREQUENCY	Models within 66 - 88 MHz (see model survey)
IMPEDANCE	Nom. 50 Ω
RADIATION	Omnidirectional
POLARIZATION	Vertical
GAIN	2 dBi 0 dBd
BANDWIDTH	12 MHz
SWR	≤ 1.6
MAX. POWER	600 W
ANTISTATIC PROTECTION	All metal parts DC-grounded (Connector shows a DC-short)

MECHANICAL	
CONNECTOR	0.5 m tail of RG 213 terminated with an N-female connector
WIND SURFACE	0.101 m ²
WIND LOAD	128 N @ 160 km/h
COLOUR	Black
MATERIALS	Black anodized, corrosion-resistant aluminium
TOTAL HEIGHT	Approx. 1.6 m
WEIGHT	Approx. 2.4 kg
MOUNTING	38 mm dia. mast tube

TYPICAL SWR - CURVE

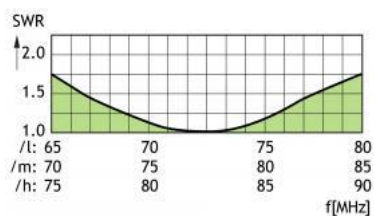

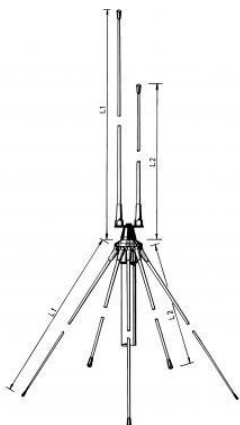

GP 80/160

>1/4 λ Glass fibre Ground-Plane Antenna for the 80 MHz and 160 MHz Bands

The radiator is measured from its free end to the bottom of the black insulator, while the radials are measured from their free ends to where they meet the GP-head. The radials must be placed short/long alternately.

- GP 80/160 is a dual-band glass fibre ground-plane antenna of the triple-leg type.
- The antenna is tunable (by cutting) within its main frequency bands: 66...88 MHz/145...175 MHz.

Description

- The cutting diagrams below indicate the length of the radiators and the radials corresponding to specific frequencies within the two bands. It is recommended to use the curves as a guide and fine-tune using an SWR-meter.
- The antenna comprises a brass GP-head, two glass fibre radiators and six glassfiber radials.
- GP 80/160 is made of first-class materials and will endure “wear and tear” for years - no maintenance required.

ORDERING DESIGNATIONS

TYPE	PRODUCT NO.
GP 80/160	100000066
GP 80/160/42 mm	100000067

SPECIFICATIONS

ELECTRICAL	
MODEL	GP 80/160
ANTENNA TYPE	Dual-band $\frac{1}{4} \lambda$ full-size ground-plane
FREQUENCY	66...88 MHz/145...175 MHz
IMPEDANCE	Nom. 50 Ω
RADIATION	Omnidirectional
POLARIZATION	Vertical
GAIN	2 dBi 0 dBd on both bands
BANDWIDTH	Approx. 5 MHz on both bands
SWR	≤ 1.2 @ f. res.
MAX. POWER	250 W
MECHANICAL	
CONNECTOR	N-female
WIND SURFACE	Approx. 0.05 m ²

WIND LOAD	63 N @ 160 km/h
COLOUR	White/bright chrome
MATERIALS	Elements : Glass fibre Metal parts : Bright chromed brass
TOTAL HEIGHT	1.8 m
WEIGHT	Approx. 1.5 kg
MOUNTING	38 mm dia. mast tube (42 mm dia. as option, see note)

PLEASE NOTE

The GP 80/160 can be delivered with a GP-head for mounting on 42 mm dia. mast tube (standard is 38 mm) when ordering as option GP 80/160/42 mm.

CUTTING DIAGRAMS

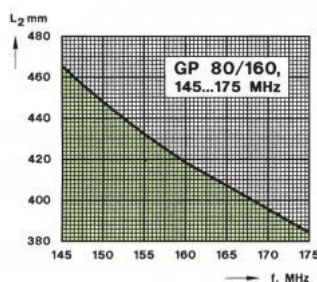
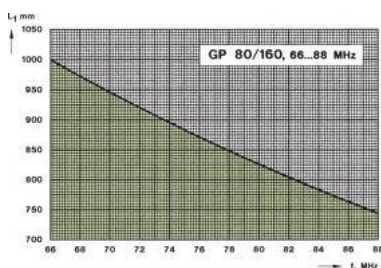



GP 80

$\frac{1}{4} \lambda$ Glass fibre Ground-Plane Antenna for the 80 MHz Band

The radiator is measured from its free end to the bottom of the black insulator, while the radials are measured from their free ends to where they meet the GP-head.

- GP 80 is a glass fibre ground-plane antenna of the triple-leg type.
- The antenna is tunable (by cutting) within its main frequency band: 66...88 MHz but is further applicable up to 150 MHz.

Description

- The cutting diagrams on the diagrams tab indicate the length of the radiator and the radials corresponding to a specific frequency. It is recommended to use the curves as a guide and fine-tune using an SWR-meter.
- The antenna comprises a brass GP-head, one glassfiber radiator and three glass fibre radials.
- GP 80 is made of first-class materials and will endure "wear and tear" for years - no maintenance required.

ORDERING DESIGNATIONS

TYPE	PRODUCT NO.
GP 80	100000061
GP 80/42 mm	100000062

SPECIFICATIONS

ELECTRICAL	
MODEL	GP 80
ANTENNA TYPE	$\frac{1}{4} \lambda$ triple-leg ground-plane
FREQUENCY	Tunable by cutting within: 66...88 MHz (Also applicable: 88...150 MHz)
IMPEDANCE	Nom. 50 Ω
RADIATION	Omnidirectional
POLARIZATION	Vertical
GAIN	2 dBi 0 dBd
BANDWIDTH	8 MHz (SWR < 2.0)
SWR	≤ 1.2 @ f. res.

MAX. POWER	1 kW
MECHANICAL	
CONNECTOR	UHF-female (fitting PL-259)
WIND SURFACE	0.043 m ²
WIND LOAD	54 N @ 160 km/h
COLOUR	White/bright chrome
MATERIALS	Elements: Glass fibre Metal parts: Bright chromed brass
TOTAL HEIGHT	Approx. 1.3 m
WEIGHT	Approx. 1.3 kg
MOUNTING	38 mm dia. mast tube (42 mm dia. as option, see note)

PLEASE NOTE

The GP 80 can be delivered with a GP-head for mounting on 42 mm dia. mast tube (standard is 38 mm) when ordering as option GP 80/42 mm.

CUTTING DIAGRAMS

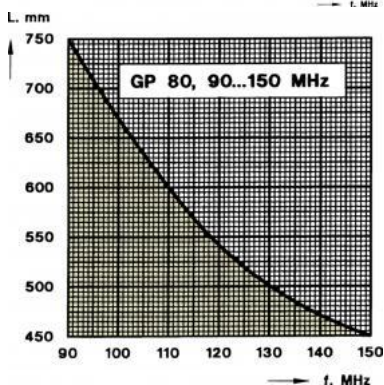
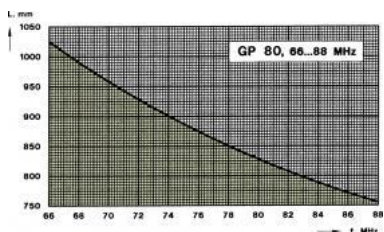

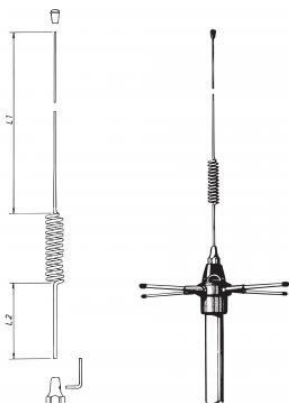

GP 450-3/...

Collinear, 3 dBd Ground-Plane Base Station and Marine Antenna for the 450 MHz Band

- The high gain of this antenna combined with its low height makes it the right choice for a wide variety of purposes.
- The antenna is delivered in two models tunable by cutting within 380...410 MHz (l-version) and 406...470 MHz (h-version), respectively.

Description

- The GP 450-3/... is especially suitable as a marine antenna in connection with 450 MHz cellular radio telephone systems making it possible to extend the normally land-based cellular system for maritime mobile service as well.
- The compactness of the GP 450-3/... also makes it highly qualified as a base station antenna.
- The higher the antenna is mounted, the better coverage. Avoid mounting the antenna parallel to or in the neighbourhood of other metal parts such as masts, supporting wires etc., otherwise the SWR and the radiation pattern may be influenced.
- The antenna is easily field-tuned following the instructions below, or it can be ordered factory-tuned for CELLULAR or customer-specified frequencies. See ordering information below.
- Materials used are 18/8 stainless steel, UV-stabilized plastic and triple-plated chromed brass.

PLEASE NOTE: The GP 450-3/... can also be delivered factory tuned to a specific frequency or cellular network, such as TETRA. In this case, please add frequency or name of the network to the antenna model, e.g. GP 450-3/390 MHz.

ORDERING DESIGNATIONS

TYPE	PRODUCT NO.	FREQUENCY
GP 450-3/l	100000134	Tunable within 380...410 MHz
GP 450-3/h	100000135	Tunable within 406...470 MHz

SPECIFICATIONS

ELECTRICAL	
MODEL	GP 450-3/...
ANTENNA TYPE	Collinear ground-plane antenna
FREQUENCY	Tunable by cutting within: l: 380...410 MHz h: 406...470 MHz
IMPEDANCE	Nom. 50 Ω
RADIATION	Omnidirectional
POLARIZATION	Vertical
GAIN	5 dBi 3 dBd
BANDWIDTH	10 MHz @ SWR < 1.5
SWR	≤ 1.3 @ f. res.

MAX. POWER	250 W
MECHANICAL	
TEMP. RANGE	-30° C → +70° C
CONNECTOR	N-female
WIND SURFACE	0.0131 m ²
WIND LOAD	17 N @ 160 km/h
COLOUR	Bright chrome
MATERIALS	Bright polished stainless steel. Bright chromed brass. Weather- and shockproof plastics
TOTAL HEIGHT	Approx. 730 mm (at 406 MHz)
DIA. IN TOP END	2 mm
DIA. IN BOTTOM END	3 mm
WEIGHT	Approx. 780 g
MOUNTING	On 27 mm dia. mast tube (¾" water pipe)

CUTTING DIAGRAM

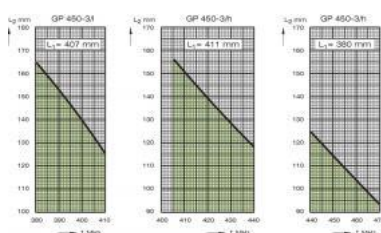

TUNING INSTRUCTIONS

The GP 450-3/...must be tuned to the operating frequency according to the following instructions:

- Only for GP 450-3/h: Cut the top section (L1) above the phasing coil as indicated in the cutting diagram, depending on whether operating in the lower end or the higher end of the band 406 – 470 MHz.
- Tune the antenna using an SWR-meter by cutting the bottom end of the whip (L2). The whip is loosened from the nipple using the accompanying hex key. Use the cutting diagram above as a guide for this procedure.

Do not cut the radials.

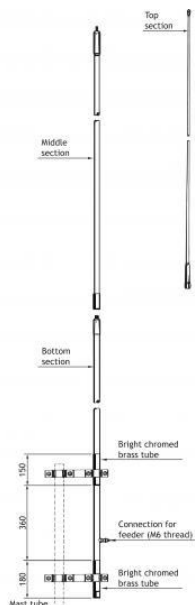

HF 7500-3

7.5 m Self-Supporting HF Transmitting Antenna for Mast Mounting

- This antenna is intended for transmitting and receiving in the MF-HF range. It is designed for mast mounting with an open feeder installation.
- The antenna has very low base capacitance for best efficiency. The power rating of the antenna depends on frequency, but it can very safely be used with 500 W transmitters over the whole MF-HF band.

DESCRIPTION

- Installation is easily carried out by means of the two hot galvanized mast clamps. The antenna has very small weight and minimum wind surface, thereby requiring only a minimum of mast strength.
- The glass fibre construction gives a stiff and self-supporting structure with extremely good resistance against the corrosive marine environment with UV-radiation, salt, exhaust gases and ice formation as the primary factors.
- HF 7500-3 is a maintenance-free and very reliable construction.

ORDERING DESIGNATIONS

TYPE	PRODUCT NO.
HF 7500-3	110000179

SPECIFICATIONS

ELECTRICAL	
MODEL	HF 7500-3
ANTENNA TYPE	Self-supporting antenna element
FREQUENCY	1.4 - 30 MHz
STATIC CAPACITY	Approx. 90 pF
INSULAT. RESISTANCE	Approx. $10^8 \Omega$
MECHANICAL LENGTH	7.5 m
EFF. ELECTR. LENGTH	7.2 m
MECHANICAL	
TEMP. RANGE	-30° C → +70° C
CONNECTOR	Open feeder. See drawing

WIND SURFACE	Approx. 0.128 m ²
WIND LOAD	Approx. 205 N @ 150 km/h
MAX. WIND SPEED	200 km/h
COLOUR	Marine white
MATERIALS	Shroud : Glass fibre Metal parts: Chromed brass
TOTAL HEIGHT	Approx. 7.5 m
DIA. IN TOP END	5 mm
DIA. IN BOTTOM END	30 mm
WEIGHT	Approx. 4.7 kg, clamps inclusive
MOUNTING	On 35 - 65 mm dia. mast tube

CLAMP DETAILS

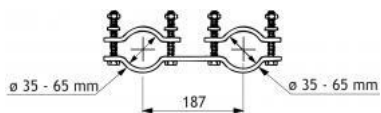

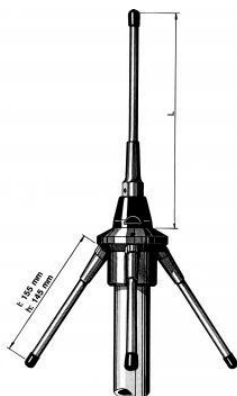

GP 450/...

$\frac{1}{4} \lambda$ Ground-Plane Antenna for the 450 MHz Band

- GP 450/... is a ground-plane antenna of the triple-leg type.
- The antenna is delivered in two models tunable over the ranges 380...430 MHz (l) and 420...470 MHz (h), respectively, by adjusting the length of the radiator.

Description

- The cutting diagram on the diagrams tab indicates how long the radiator must be corresponding to a specific centre frequency. The radiator is measured from its free end (excl. top knob) to the bottom of the black insulator. Do not cut the radials - they should be left untouched.
- GP 450/... comprises a GP-head, one radiator and threeradials - all made of chromed brass.
- GP 450/... is made of first-class materials and will endure "wear and tear" for years - no maintenance required.

ORDERING DESIGNATIONS

TYPE NO.	PRODUCT NO.	FREQUENCY
GP 450/l	100000128	Tunable within 380...430 MHz
GP 450/l-42 mm	100000130	Same as above
GP 450/h	100000129	Tunable within 420...470 MHz
GP 450/h-42 mm	100000133	Same as above

SPECIFICATIONS

ELECTRICAL	
MODEL	GP 450/...
ANTENNA TYPE	$\frac{1}{4} \lambda$ ground-plane antenna
FREQUENCY	l: 380...430 MHz h: 420...470 MHz
IMPEDANCE	Nom. 50 Ω
RADIATION	Omnidirectional
POLARIZATION	Vertical
GAIN	2 dBi 0 dBd
BANDWIDTH	40 MHz @ SWR 2.0
SWR	≤ 1.2 @ f. res.
MAX. POWER	1 kW
MECHANICAL	

TEMP. RANGE	-30° C → +70° C
CONNECTOR	UHF-female (fitting PL-259)
WIND SURFACE	0.0128 m ²
WIND LOAD	16 N @ 160 km/h
COLOUR	Bright chrome
MATERIALS	Chromed brass. Weather- and shockproof plastics
TOTAL HEIGHT	Approx. 340 mm
ANTENNA ELEMENT DIA.	8 mm
WEIGHT	Approx. 900 g
MOUNTING	38 mm dia. mast tube (42 mm dia. as option, see note)

PLEASE NOTE

The GP 450/... can be delivered with a GP-head for mounting on 42 mm dia. mast tube (standard is 38 mm) when ordering as option **GP 450/...-42 mm.**

CUTTING DIAGRAM

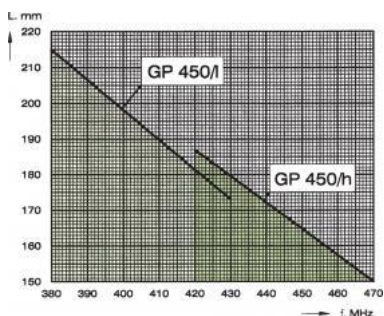



HF 5000

5 m Self-Supporting HF Transmitting Antenna for Mast Mounting

- This antenna is intended for transmitting and receiving in the MF-HF range. It is designed for mast mounting with an open feeder installation.
- The antenna has very low base capacitance for best efficiency. The power rating of the antenna depends on frequency, but it can very safely be used with 400 W transmitters over the whole MF-HF band.

DESCRIPTION

- Installation is easily carried out by means of the two hot galvanized mast clamps. The antenna has very small weight and minimum wind surface, thereby requiring only a minimum of mast strength.
- The glass fibre construction gives a stiff and self-supporting structure with extremely good resistance against the corrosive marine environment with UV-radiation, salt, exhaust gases and ice formation as the primary factors.
- HF 5000 is a maintenance-free and very reliable construction.

ORDERING DESIGNATIONS

TYPE NO.	PRODUCT NO.
HF 5000	110000109

SPECIFICATIONS

ELECTRICAL	
MODEL	HF 5000
ANTENNA TYPE	Self-supporting antenna element
FREQUENCY	1.4 – 30 MHz
STATIC CAPACITY	Approx. 60 pF
INSULAT. RESISTANCE	Approx. $10^8 \Omega$
MECHANICAL LENGTH	5 m
EFF. ELECTR. LENGTH	4.40 m
MECHANICAL	
TEMP. RANGE	-30° C → +70° C
CONNECTOR	Open feeder. See drawing
WIND SURFACE	0.082 m ²
WIND LOAD	106 N @ 150 km/h
MAX. WIND SPEED	200 km/h

COLOUR	Marine white
MATERIALS	Shroud : Glass fibre Metal parts: Stainless steel and chromed brass
TOTAL HEIGHT	Approx. 5.17 m
DIA. IN TOP END	5 mm
DIA. IN BOTTOM END	20 mm
WEIGHT	2.7 kg, clamps inclusive
MOUNTING	On 35 - 65 mm dia. mast tube

CLAMP DETAILS

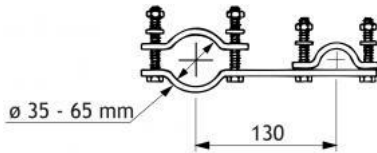



GP 40

$\frac{1}{4} \lambda$ Glass fibre Ground-Plane Antenna for the 40 - 70 MHz Range

- GP 40 is a glass fibre ground-plane antenna of the triple-leg type.
- The antenna is tunable (by cutting) within: 40...70 MHz.

- The cutting diagrams below indicate the length of the radiator and the radials corresponding to a specific frequency. It is recommended to use the curves as a guide and fine-tune using an SWR-meter.
- The antenna comprises a brass GP-head, one glass fibre radiator and three glass fibre radials.
- GP 40 is made of first-class materials and will endure "wear and tear" for years - no maintenance required.

ORDERING DESIGNATIONS

TYPE	PRODUCT NO.
GP 40	100000165
GP 40/42 mm	100000167

SPECIFICATIONS

ELECTRICAL	
MODEL	GP 40
ANTENNA TYPE	$\frac{1}{4} \lambda$ triple-leg ground-plane
FREQUENCY	Tunable by cutting within: 40...70 MHz
IMPEDANCE	Nom. 50 Ω
RADIATION	Omnidirectional
POLARIZATION	Vertical
GAIN	2 dBi 0 dBd
BANDWIDTH	1.5 MHz @ 40 MHz (SWR \leq 1.5) 3 MHz @ 70 MHz (SWR \leq 1.5)
SWR	< 1.2 @ f. res.
MAX. POWER	1 kW
MECHANICAL	

CONNECTOR	UHF-female (fitting PL-259)
WIND SURFACE	0.075 m ²
WIND LOAD	95 N @ 160 km/h
COLOUR	White/bright chrome
MATERIALS	Elements: Glass fibre Metal parts: Bright chromed brass
TOTAL HEIGHT	Approx. 3.2 m
WEIGHT	Approx. 1.6 kg
MOUNTING	38 mm dia. mast tube (42 mm dia. as option, see note)

PLEASE NOTE

The GP 40 can be delivered with a GP-head for mounting on 42 mm dia. mast tube (standard is 38 mm) when ordering as option GP 40/42 mm.

The radiator is measured from its free end to the bottom of the black insulator, while the radials are measured from their free ends to where they meet the GP-head.

CUTTING DIAGRAMS

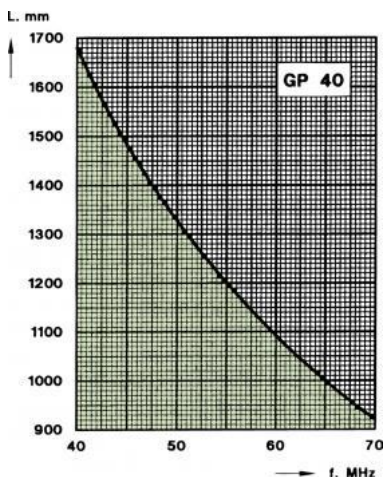



GP 160 B

Broad-banded, Antistatic Ground-Plane Antenna for the 160 MHz Band

- GP 160 B is a broad-banded, 0 dBd, ground-plane antenna of the triple-leg type.
- The antenna is fully universal as it covers the complete band: 145 - 175 MHz.

- Atmospheric discharges are immediately led to ground, as all metal parts are DC-grounded. (Consequently, the antenna shows a DC-short across the coaxial cable).
- GP 160 B is made from corrosion-resistant aluminium, which together with a special anodizing process gives this antenna a very long lifetime.

ORDERING DESIGNATIONS

TYPE	PRODUCT NO.
GP 160 B	100000107

SPECIFICATIONS

ELETRICAL	
MODEL	GP 160 B
ANTENNA TYPE	$\frac{1}{4} \lambda$ ground-plane, broad-banded
FREQUENCY	Covering: 145 - 175 MHz
IMPEDANCE	Nom. 50 Ω
RADIATION	Omnidirectional
POLARIZATION	Vertical
GAIN	2 dBi 0 dBd
BANDWIDTH	30 MHz
SWR	≤ 1.6
MAX. POWER	1 kW
ANTISTATIC PROTECTION	All metal parts DC-grounded (Shows a DC-short over the coaxial cable)
MECHANICAL	
TEMP. RANGE	-35° C \rightarrow +70° C
CONNECTOR	0.5 m tail of RG 213 terminated with an N-female connector

WIND SURFACE	0.046 m ²
WIND LOAD	58 N @ 160 km/h
COLOUR	Black
MATERIALS	Black anodized, corrosion-resistant aluminium
TOTAL HEIGHT	Approx. 0.72 m
WEIGHT	Approx. 1.5 kg
MOUNTING	On 38 mm dia. mast tube

TYPICAL GAIN AND SWR CURVES

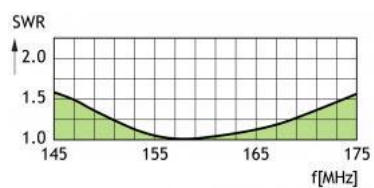

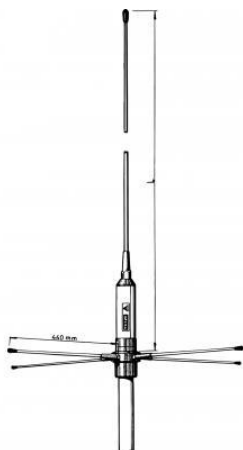

GP 160 5/8

$\frac{5}{8} \lambda$ Ground-Plane Base Station and Marine Antenna for the 2 m Band

- The antenna is tunable (by cutting the radiator) within the frequency band 145...175 MHz.
- GP 160 5/8 is a very sturdy construction which can stand mounting under extreme conditions. It is well suited for mounting on fishing vessels etc. and a good choice for base stations in the land mobile field.

- GP 160 5/8 is a 1 dBd, vertically polarised omnidirectional base station and marine antenna.
- The antenna is delivered adjusted to 145 MHz unless otherwise specified. It may, however, be delivered preadjusted for the maritime VHF band provided this is stated on the purchase order.
- GP 160 5/8 is DC-grounded and antistatically protected as all metal parts are ground-connected. Consequently, the antenna shows a DC-short across the coaxial cable.
- The materials used are glass fibre and chromed brass.

ORDERING DESIGNATIONS

TYPE	PRODUCT NO.
GP 160 5/8	100000108

SPECIFICATIONS

ELECTRICAL	
MODEL	GP 160 5/8
ANTENNA TYPE	$\frac{5}{8} \lambda$ ground-plane
FREQUENCY	Tunable by cutting within: 145...175 MHz
IMPEDANCE	Nom. 50 Ω
RADIATION	Omnidirectional
POLARIZATION	Vertical
GAIN	3 dBi 1 dBd
BANDWIDTH	6 MHz (SWR \leq 2.0)
SWR	\leq 1.2 @ f. res.
MAX. POWER	500 W
ANTISTATIC PROTECTION	All metal parts DC-grounded (Connector shows a DC-short)
MECHANICAL	
TEMP. RANGE	-30° C \rightarrow +70° C

CONNECTOR	UHF-female (fitting PL-259)
WIND SURFACE	0.028 m ²
WIND LOAD	35 N @ 160 km/h
COLOUR	White/bright chrome
MATERIALS	Shroud : Polyurethane-coated glass fibre Metal parts: Bright chromed brass
TOTAL HEIGHT	Approx. 1.34 m
DIA. IN TOP END	5 mm
DIA. IN BOTTOM END	8 mm
WEIGHT	Approx. 1.3 kg
MOUNTING	On 27 mm dia. mast tube (3/4" water pipe)

The length of the radiator is measured from the upper edge of the head, right above the mounting point of the radials, to the top end of the antenna element. The radials should not be cut.

CUTTING DIAGRAM

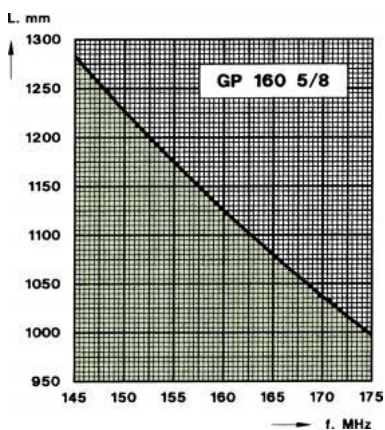



GP 160

$\frac{1}{4} \lambda$ Glass fibre Ground-Plane Antenna for the 160 MHz Band

- GP 160 is a glass fibre ground-plane antenna of the triple-leg type.
- The antenna is tunable (by cutting) within its main frequency band: 145...175 MHz, but is further applicable up to 400 MHz.

- The cutting diagrams below indicate the length of the radiator and the radials corresponding to a specific frequency.
- It is recommended to use the curves as a guide and fine-tune using an SWR-meter.
- The antenna comprises a GP-head made of chromed brass, one glassfiber radiator and three glass fibre radials.
- GP 160 is made of first-class materials and will endure "wear and tear" for years - no maintenance required.

ORDERING DESIGNATIONS

TYPE	PRODUCT NO.
GP 160	100000104
GP 160/42 mm	100000105

SPECIFICATIONS

ELETRICAL	
MODEL	GP 160
ANTENNA TYPE	$\frac{1}{4} \lambda$ ground-plane
FREQUENCY	Tunable by cutting within: 145...175 MHz (Also applicable: 175...400 MHz)
IMPEDANCE	Nom. 50 Ω
RADIATION	Omnidirectional
POLARIZATION	Vertical
GAIN	2 dBi 0 dBd
BANDWIDTH	12 MHz @ 160 MHz (SWR < 2.0) 30 MHz @ 400 MHz (SWR < 2.0)
SWR	≤ 1.2 @ f. res.
MAX. POWER	1 kW
MECHANICAL	
TEMP. RANGE	-30° C \rightarrow +70° C

CONNECTOR	UHF-female (fitting PL-259)
WIND SURFACE	0.0184 m ²
WIND LOAD	23 N @ 160 km/h
COLOUR	White/bright chrome
MATERIALS	Shroud : Polyurethane-coated glass fibre Metal parts: Bright chromed brass
TOTAL HEIGHT	Approx. 870 mm
DIA. IN TOP END	5 mm
DIA. IN BOTTOM END	8 mm
WEIGHT	Approx. 1.0 kg
MOUNTING	38 mm dia. mast tube (42 mm dia. as option, see note)

PLEASE NOTE

The GP 160 can be delivered with a GP-head for mounting on 42 mm dia. mast tube (standard is 38 mm) when ordering as option GP 160/42 mm.

The radiator is measured from its free end to the bottom of the black insulator, while the radials are measured from their free ends to where they meet the GP-head.

CUTTING DIAGRAMS

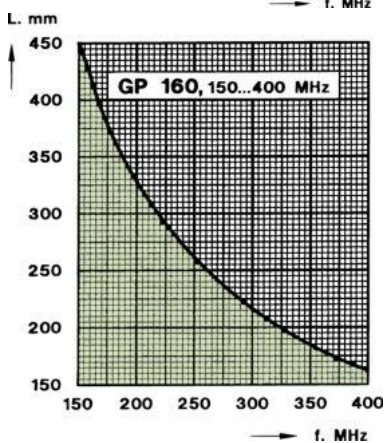
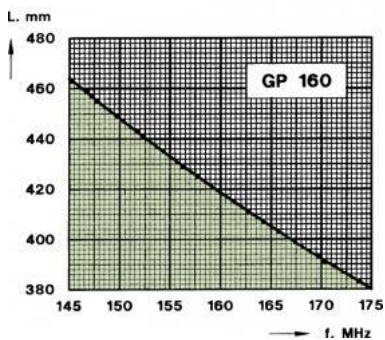



CXL 2400-6LW/...

6 dBd Omdirectional Base Station and Marine Antenna for the 2400 MHz Band

- Vertically polarized, omnidirectional base station and marine antenna.
- Approximately 6 dBd gain.

DESCRIPTION

- Provided with the sturdy "LW" mast mount - a lightweight, multipurpose, epoxy-coated mounting bracket made of non-corrosive aluminium.
- The accompanying U-bolts and fittings are made of stainless steel.
- To be mounted on vertical or horizontal mast tubes, 16 to 54 mm in outer diameter.
- The cable can be led either on the outside or along the inside of the mast tube.
- Large bandwidth with respect to both SWR and gain.
- Highly suitable for duplex operation with large spacing between the TX and the RX frequencies.
- The antenna element is sealed in a high-quality, conical glass fibre tube.
- All metal parts in the antenna are DC-grounded to reduce the noise caused by atmospherical discharge. Consequently, the antenna shows a DC-short across the coaxial cable.
- The CXL 2400-6LW/... is a vibration-proof, lightweight, slim-line, corrosion resistant, modern style base station and marine antenna.

ORDERING DESIGNATIONS

TYPE	PRODUCT NO.	FREQUENCY
CXL 2400-6LW/II	100000412	2200 - 2300 MHz
CXL 2400-6LW/I	100000182	2300 - 2500 MHz
CXL 2400-6LW/m	100000185	2400 - 2600 MHz
CXL 2400-6LW/h	100000176	2500 - 2700 MHz

SPECIFICATIONS

ELECTRICAL	
MODEL	CXL 2400-6LW/...
ANTENNA TYPE	Coaxial, collinear antenna, broadbanded
FREQUENCY	Models within 2200 - 2700 MHz
IMPEDANCE	Nom. 50 Ω
POLARIZATION	Vertical
GAIN	8 dBi 6 dBd
HALF POWER BEAMWIDTH	9°

BANDWIDTH	≥ 200 MHz @ SWR ≤ 2.0
SWR	≤ 2.0, typ. ≤ 1.5
MAX. POWER	100 W
ANTISTATIC PROTECTION	All metal parts DC-grounded (Connector shows a DC-short)
MECHANICAL	
TEMP. RANGE	-30°C → +70°C
CONNECTOR	N-female
WIND SURFACE	Approx. 0.033 m ²
WIND LOAD	Approx. 42 N @ 160 km/h
COLOUR	Marine white
MATERIALS	Shroud: Polyurethane-coated glass fiber Mounting bracket: Seawater resistant aluminium, epoxy-coated Clamps: Stainless steel
TOTAL HEIGHT	Approx. 1 m
DIA. IN TOP END	21 mm
DIA. IN BOTTOM END	23 mm
WEIGHT	Approx. 800 g
MOUNTING	On 16 to 54 mm dia. mast tube

TYPICAL GAIN AND SWR CURVES

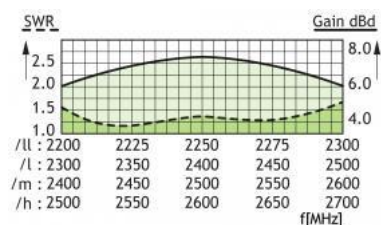

TYPICAL RADIATION PATTERN (E-PLANE)

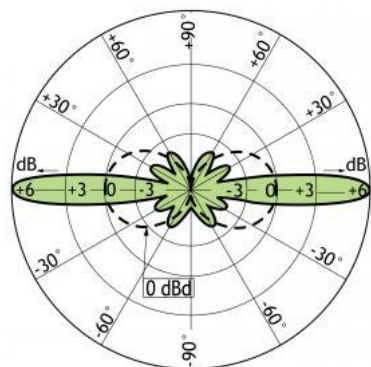

TYPICAL RADIATION PATTERN (H-PLANE)

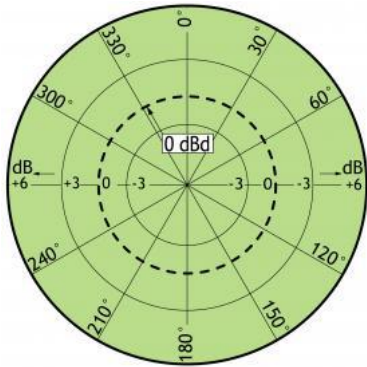

MULTI-PURPOSE MOUNTING BRACKET

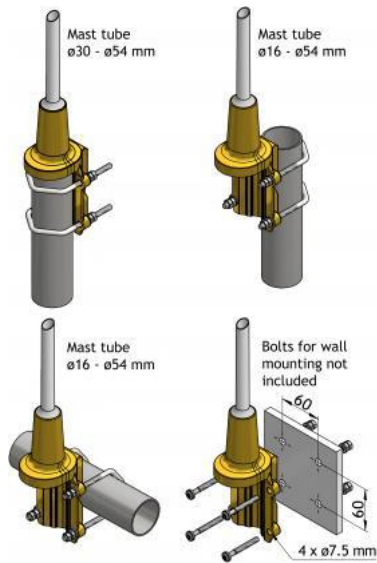

PLEASE NOTE

The antenna is delivered with a DC-connection between the antenna element and the mounting bracket.



CXL 2400-3/...

3 dBd Omnidirectional Base Station and Marine Antenna for the 2400 MHz Band

- Vertically polarized, omnidirectional base station and marine antenna.
- Approximately 3 dBd gain.

DESCRIPTION

- Simple mounting using the 1" revolving nut system.
- Wide variety of accessory mounting brackets available.
- Large bandwidth with respect to both SWR and gain.
- Highly suitable for duplex operation with large spacing between the TX and the RX frequencies.
- The antenna element is sealed in a high-quality, conical glass fibre tube.
- All metal parts in the antenna are DC-grounded to reduce the noise caused by atmospherical discharge. Consequently, the antenna shows a DC-short across the coaxial cable.
- The CXL 2400-3/... is a vibration-proof, lightweight, slim-line, corrosion resistant, modern style base station and marine antenna.

ORDERING DESIGNATIONS

TYPE	PRODUCT NO.	FREQUENCY
CXL 2400-3/II	100000586	2200 - 2300 MHz
CXL 2400-3/I	110000157	2300 - 2500 MHz
CXL 2400-3/m	110000158	2400 - 2600 MHz
CXL 2400-3/h	110000159	2500 - 2700 MHz

SPECIFICATIONS

ELECTRICAL	
MODEL	CXL 2400-3/...
ANTENNA TYPE	Coaxial, collinear antenna, broad-banded
FREQUENCY	Models within 2200 - 2700 MHz
IMPEDANCE	Nom. 50 Ω
POLARIZATION	Vertical
GAIN	5 dBi 3 dBd
BANDWIDTH	≥ 200 MHz @ SWR ≤ 2.0
SWR	≤ 2.0, typ. ≤ 1.5
MAX. POWER	100 W

ANTISTATIC PROTECTION	All metal parts DC-grounded (Connector shows a DC-short)
MECHANICAL	
TEMP. RANGE	-30°C → +70°C
CONNECTOR	N-female
WIND SURFACE	Approx. 0.01 m ²
WIND LOAD	Approx. 13 N @ 160 km/h
COLOUR	Marine white
MATERIALS	Shroud: Polyurethane-coated glass fibre Mounting bracket: Chromed brass
TOTAL HEIGHT	Approx. 550 mm
DIA. IN TOP END	22 mm
DIA. IN BOTTOM END	23 mm
WEIGHT	Approx. 400 g
MOUNTING	On 1" RG (G1"-11) threaded water pipe or on optional mounting brackets (see below)

ACCESSORIES (to be ordered separately)

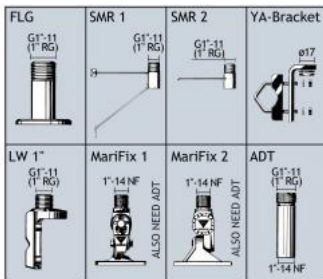

TYPICAL GAIN AND SWR CURVES

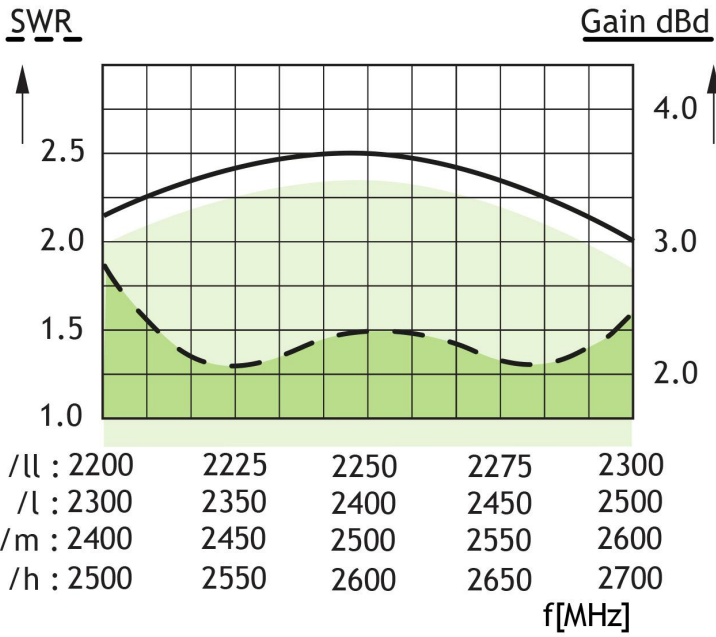

/ll : 2200	2225	2250	2275	2300
/l : 2300	2350	2400	2450	2500
/m : 2400	2450	2500	2550	2600
/h : 2500	2550	2600	2650	2700

TYPICAL RADIATION PATTERN (E-PLANE)

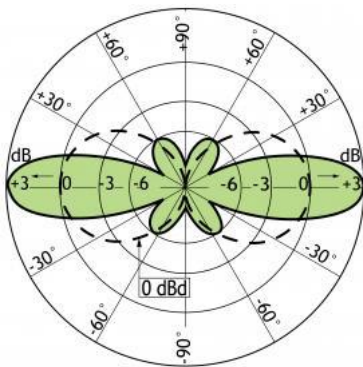

TYPICAL RADIATION PATTERN (H-PLANE)





CXL 2/70C

Dual-frequency, Base Station Antenna for the 160 MHz and 450 MHz Bands

- CXL 2/70C is a dual-frequency base station antenna - two bands with only one antenna.

DESCRIPTION

- This antenna makes it possible to:
 - operate 160 and 450 MHz transceivers alternately on the same antenna
 - operate two transceivers (160 and 450 MHz) at the same time on one antenna using a diplexer (type DIPX 225/330 - must be ordered separately).
- CXL 2/70C is designed for fixation on supporting tubes with outer diameter between 27 mm and 65 mm.
- The construction of the mount makes it possible to lead the cable either inside or along the outside of the mast tube.
- Atmospheric discharges are immediately led to ground as all metal parts are DC-grounded (consequently, the antenna shows a DC-short across the coaxial cable).

ORDERING DESIGNATIONS

TYPE	PRODUCT NO.
CXL 2/70C	100000103

SPECIFICATIONS

ELECTRICAL	
MODEL	CXL 2/70C
ANTENNA TYPE	Coaxial, dual-frequency base station antenna
FREQUENCY	160 MHz-band freq. to be stated within: 144 - 175 MHz 450 MHz-band freq. to be stated within: 380 - 470 MHz
IMPEDANCE	Nom. 50 Ω
RADIATION	Omnidirectional
POLARIZATION	Vertical
GAIN	Approx. 2 dBi 0 dBd
BANDWIDTH	160 MHz: ≥ 8 MHz @ SWR 2.0 450 MHz: ≥ 20 MHz @ SWR 2.0
SWR	≤ 1.5 @ f. res. in both bands
MAX. POWER	100 W (for each band)

ANTISTATIC PROTECTION	All metal parts DC-grounded (Connector shows a DC-short)
MECHANICAL	
CONNECTOR	N-female
WIND SURFACE	0.067 m ²
WIND LOAD	85 N @ 160 km/h
COLOUR	Marine white
MATERIALS	Radome : Polyurethane-coated glass fibre Mounting bracket: Seawater resistant aluminium, epoxy-coated
TOTAL HEIGHT	Approx. 1.3 m
WEIGHT	Approx. 2.5 kg
MOUNTING	On 27 - 65 mm dia. mast tube

ORDERING

The antenna is delivered factory-tuned to two single frequencies or two frequency-bands. These two frequencies (stated in MHz) must be specified when ordering.

TYPICAL GAIN AND SWR CURVES

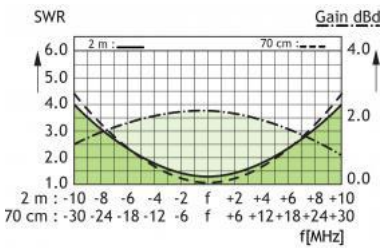

TYPICAL RADIATION PATTERN (E-PLANE)

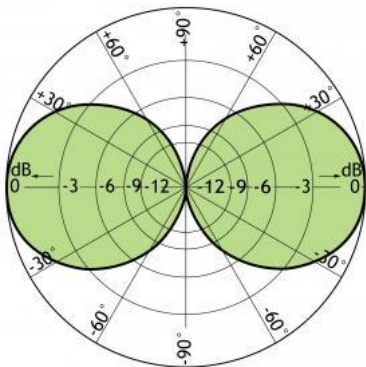

TYPICAL RADIATION PATTERN (H-PLANE),



MULTI-PURPOSE MOUNTING BRACKET

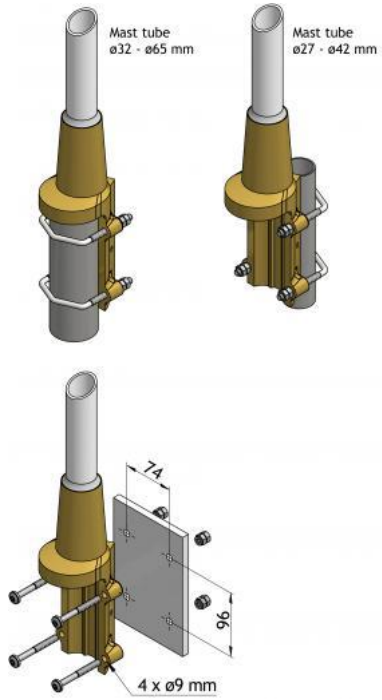



CXL 2-5HD/...

Sturdy, 5 dBd Gain, Base Station Antenna for the 160 MHz Band

- CXL 2-5HD/... is a 5 dBd, vertically polarized, omnidirectional base station antenna.
- The antenna has a bandwidth of 7 MHz. Please specify centre frequency or duplex TX and RX when ordering.

DESCRIPTION

- The antenna is provided with our sturdy type "HD" mast mount, which is a heavy-duty, multipurpose mounting bracket made of non-corrosive aluminium. The accompanying U-bolts and fittings are made of stainless steel.
- The antenna can be mounted on mast tubes of 58 to 105 mm in outer diameter. Further, the construction of the mount makes it possible to lead the cable either along the inside or on the outside of the mast tube.
- In designing this antenna, special emphasis has been laid on obtaining a large bandwidth both in relation to SWR and gain. The phasing of the radiating elements is carefully adjusted to yield maximum gain in the horizontal plane, with the level of the sidelobes reduced to a minimum.
- The antenna element is sealed in a high-quality, conical glass fibre tube with low wind-load, which will ensure performance undisturbed in all climates.
- To substantially reduce noise caused by atmospherical discharges, all metal parts in the antenna are DC-grounded. Consequently, the antenna shows a DC-short across the coaxial cable.
- CXL 2-5HD/... is a vibration-proof, lightweight, slim-line, corrosion-resistant, modern style base station antenna.

ORDERING DESIGNATIONS

TYPE	PRODUCT NO.
CXL 2-5HD/...	100000101

SPECIFICATIONS

ELECTRICAL	
MODEL	CXL 2-5HD/...
ANTENNA TYPE	High-gain collinear
FREQUENCY	7 MHz wide frequency segments within the 144 - 175 MHz range. Please specify centre frequency, or duplex TX and RX
IMPEDANCE	Nom. 50 Ω
RADIATION	Omnidirectional
POLARIZATION	Vertical
GAIN	7 dBi 5 dBd
HALF POWER BEAMWIDTH	18°
BANDWIDTH	7 MHz
SWR	≤ 1.5
MAX. POWER	500 W

ANTISTATIC PROTECTION	All metal parts DC-grounded (connector shows a DC-short)
MECHANICAL	
TEMP. RANGE	-30°C → +70°C
CONNECTOR	N-female
WIND SURFACE	0.382 m ²
WIND LOAD	483 N @ 160 km/h
BENDING TORQUE	Below "HD"-bracket, at 150 km/h: Approx. 1.27 kNm
COLOUR	Marine white
MATERIALS	Radome : Polyurethane-coated glass fibre Mounting bracket : Seawater resistant aluminium, polyester coated
TOTAL HEIGHT	Approx. 6.6 m (Dep. on frequency)
WEIGHT	Approx. 10 kg
MOUNTING	On 58 - 105 mm dia. mast tube

MULTI-PURPOSE MOUNTING BRACKET

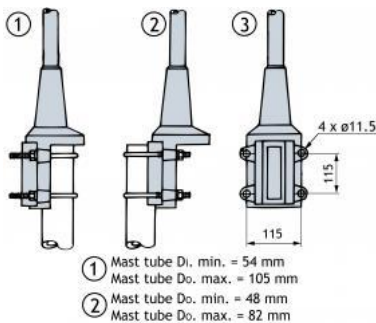

PLEASE NOTE

When using the CXL 2-5HD/... at windy locations where wind speeds of more than 150 km/h can be expected, the antenna must be mounted on the side of the mast and the top section of the glassfibre tube stabilized with a bracket.

TYPICAL GAIN AND SWR CURVES

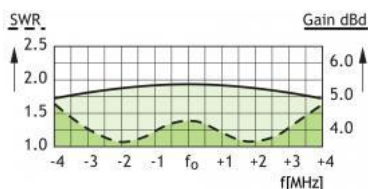

TYPICAL RADIATION PATTERN (E-PLANE)

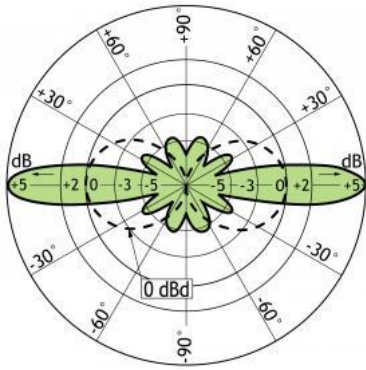

TYPICAL RADIATION PATTERN (H-PLANE)

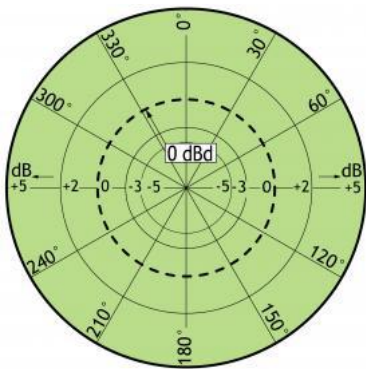



CXL 2-3LW/...

Lightweight, 3 dBd Base Station and Marine Antenna for the 2 m Band

- CXL 2-3LW/... is a 3 dBd, vertically polarised, omnidirectional base station and marine antenna, which covers the VHF-band in 5 models.
- Provided with the sturdy "LW" mast mount - a lightweight, multipurpose, epoxy-coated mounting bracket made of non-corrosive aluminium.

DESCRIPTION

- The accompanying U-bolts and fittings are made of stainless steel.
- To be mounted on vertical or horizontal mast tubes, 16 to 54 mm in outer diameter.
- The cable can be led either on the outside or along the inside of the mast tube.
- Large bandwidth with respect to both SWR and gain.
- The phasing of the radiating elements is adjusted to yield maximum gain in the horizontal plane, with the level of the sidelobes reduced to a minimum.
- The carefully designed, broad-banded antenna element is sealed in a high-quality conical glass fibre tube with low wind-load, which will ensure performance undisturbed by corrosive environments.
- To substantially reduce noise caused by atmospherical discharges, all metal parts in the antenna are DC-grounded. Consequently, the antenna shows a DC-short across the coaxial cable.
- The CXL 2-3LW/... is a vibration-proof, lightweight, slim-line, corrosion resistant, modern style base station and marine antenna.

ORDERING DESIGNATIONS

TYPE	PRODUCT NO.	FREQUENCY
CXL 2-3LW/s	100000473	137 - 150 MHz
CXL 2-3LW/l	100000092	146 - 154 MHz
CXL 2-3LW/lm	100000091	153 - 162 MHz
CXL 2-3LW/hm	100000093	158 - 167 MHz
CXL 2-3LW/h	100000090	166 - 175 MHz

SPECIFICATIONS

ELECTRICAL	
MODEL	CXL 2-3LW/...
ANTENNA TYPE	Broad-banded collinear antenna
FREQUENCY	Bands within 137 - 175 MHz
IMPEDANCE	Nom. 50 Ω
RADIATION	Omnidirectional
POLARIZATION	Vertical

GAIN	5 dBi 3 dBd
HALF POWER BEAMWIDTH	30°
BANDWIDTH	9 MHz
SWR	≤ 1.5
MAX. POWER	150 W
ANTISTATIC PROTECTION	All metal parts DC-grounded (connector shows a DC-short)
MECHANICAL	
TEMP. RANGE	-30°C → +70°C
CONNECTOR	N-female
WIND SURFACE	0.0651 m ²
WIND LOAD	82 N @ 160 km/h
COLOUR	Marine white
MATERIALS	Shroud: Polyurethane-coated glass fibre Mounting bracket: Seawater resistant aluminium, epoxy-coated Clamps: Stainless steel
TOTAL HEIGHT	Approx. 2.8 m
DIA. IN TOP END	15 mm
DIA. IN BOTTOM END	23 mm
WEIGHT	Approx. 1.4 kg
MOUNTING	On 16 to 54 mm dia. mast tube

TYPICAL GAIN AND SWR CURVES

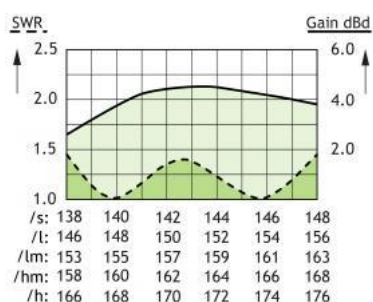

TYPICAL RADIATION PATTERN (E-PLANE)

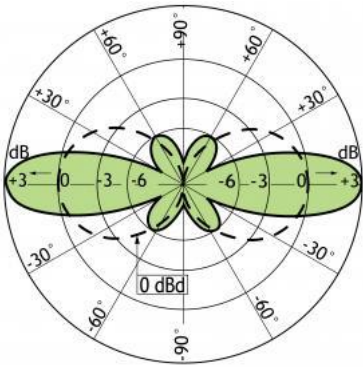

TYPICAL RADIATION PATTERN (H-PLANE)



MULTI-PURPOSE MOUNTING BRACKET

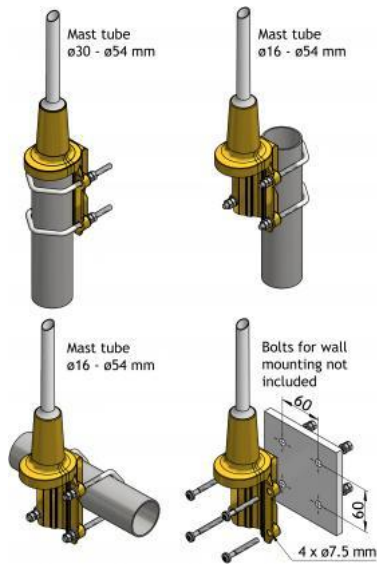

PLEASE NOTE

The antenna is delivered with a DC-connection between the antenna element and the mounting bracket.



CXL 2-3C/...

Sturdy, 3 dBd Gain Base Station Antenna for the 160 MHz Band

- CXL 2-3C/... is a sturdy, 3 dBd, vertically polarized, omnidirectional base station antenna, which covers the 160 MHz band in 4 models.
- The antenna is provided with our "C" mast bracket, which is a universal, epoxy-coated mounting bracket made of non-corrosive aluminium. The accompanying U-bolts and fittings are made of stainless steel.

DESCRIPTION

- The antenna can be mounted on 27 to 65 mm dia. mast tubes and it is possible to lead the cable either along the inside or on the outside of the mast tube.
- The phasing of the radiating elements is carefully adjusted to yield maximum gain in the horizontal plane, with the level of the sidelobes reduced to a minimum. Special emphasis has been laid on obtaining a large bandwidth both in relation to SWR and gain.
- The broad-banded antenna element is completely enclosed in a glass fibre shroud, which will ensure performance undisturbed by corrosive environments.
- To substantially reduce noise caused by atmospherical discharges, all metal parts in the antenna are DC-grounded. Consequently, the antenna shows a DC-short across the coaxial cable.
- This antenna is constructed to ensure long dependable service in all climates.

ORDERING DESIGNATIONS

TYPE	PRODUCT NO.	FREQUENCY
CXL 2-3C/s	100000096	137 - 150 MHz
CXL 2-3C/l	100000097	144 - 157 MHz
CXL 2-3C/m	100000098	153 - 166 MHz
CXL 2-3C/h	100000095	162 - 175 MHz

SPECIFICATIONS

ELECTRICAL	
MODEL	CXL 2-3C/...
ANTENNA TYPE	Collinear, broad-banded
FREQUENCY	137 - 175 MHz covered by 4 models. See model survey
IMPEDANCE	Nom. 50 Ω
RADIATION	Omnidirectional
POLARIZATION	Vertical
GAIN	5 dBi 3 dBd
HALF POWER BEAMWIDTH	30°

BANDWIDTH	13 MHz
SWR	≤ 1.5
MAX. POWER	400 W
ANTISTATIC PROTECTION	All metal parts DC-grounded (connector shows a DC-short)
MECHANICAL	
CONNECTOR	N-female
WIND SURFACE	0.143 m ²
WIND LOAD	181 N @ 160 km/h
COLOUR	Marine white
MATERIALS	Radome : Polyurethane-coated glass fibre Mounting bracket : Seawater resistant aluminium, epoxy-coated
TOTAL HEIGHT	Approx. 2.95 m (Dep. on frequency)
WEIGHT	Approx. 4.2 kg
MOUNTING	On 27 - 65 mm dia. mast tube

TYPICAL GAIN AND SWR CURVES

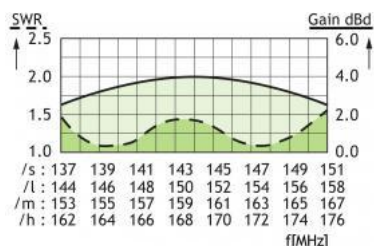

TYPICAL RADIATION PATTERN (E-PLANE)

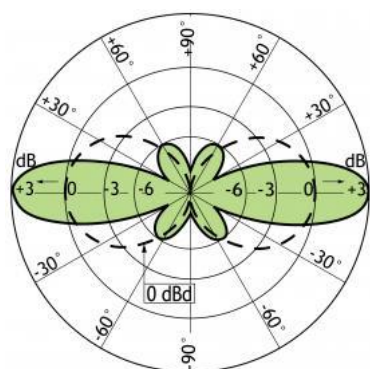

TYPICAL RADIATION PATTERN (H-PLANE)



MULTI-PURPOSE MOUNTING BRACKET

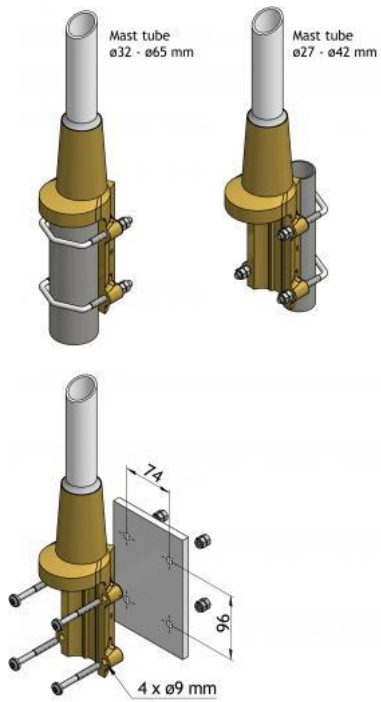



CXL 2-3

3 dBd Collinear Antenna for the Base Station and Maritime VHF Band

- This antenna is especially developed for the base station and maritime VHF band and it is used when more gain is required than obtainable with standard $\frac{1}{2} \lambda$ dipoles.
- The 1" revolving nut mounting system is standard throughout the maritime sector, and several different mounting brackets are available, making it possible to install the antenna either on the masthead, side mounted on the mast or mounted on the cross-beam. Also, the antenna can be mounted on deck or rooftop by means of the FLG. (See accessories).

DESCRIPTION

- The higher the antenna is mounted, the better coverage. Avoid mounting the antenna parallel with or in the neighbourhood of other metal parts, such as masts, supporting wires etc. The antenna needs no ground-plane, radials nor other auxiliary arrangements.
- CXL 2-3 is broad-banded, having a good SWR on the RX-frequencies as well as on the TX-frequencies. All metal parts are at ground potential and consequently, the antenna shows a DC-short across the coaxial cable.
- A conical glass fibre tube completely encloses the carefully designed radiating element to ensure long dependable service in all climates.

ORDERING DESIGNATIONS

TYPE	PRODUCT NO.
CXL 2-3	110000130

SPECIFICATIONS

ELECTRICAL	
MODEL	CXL 2-3
ANTENNA TYPE	Omnidirectional coaxial collinear
FREQUENCY	156 - 162 MHz
IMPEDANCE	Nom. 50 Ω
POLARIZATION	Vertical
GAIN	5 dBi 3 dBd
BANDWIDTH	6 MHz
SWR	≤ 1.5
MAX. POWER	150 W
ANTISTATIC PROTECTION	All metal parts DC-grounded (Connector shows a DC-short)
MECHANICAL	

TEMP. RANGE	-30°C → +70°C
CONNECTOR	UHF-female
WIND SURFACE	0.0527 m ²
WIND LOAD	67 N @ 160 km/h
COLOUR	Marine white
MATERIALS	Shroud: Polyurethane-coated glass fibre Mounting bracket: Chromed brass
TOTAL HEIGHT	Approx. 2.60 m
DIA. IN TOP END	15 mm
DIA. IN BOTTOM	23 mm
WEIGHT	Approx. 1 kg
MOUNTING	On 1" RG (G1" - 11) threaded water pipe or on optional mounting brackets (see below)

ACCESSORIES (to be ordered separately)

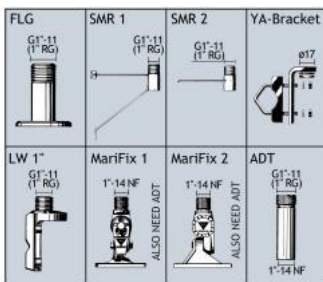

TYPICAL GAIN AND SWR CURVES

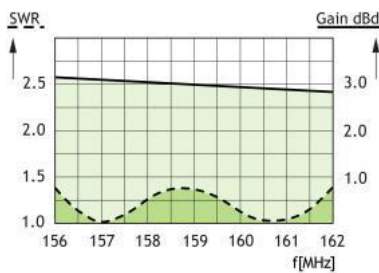

TYPICAL RADIATION PATTERN (E-PLANE)

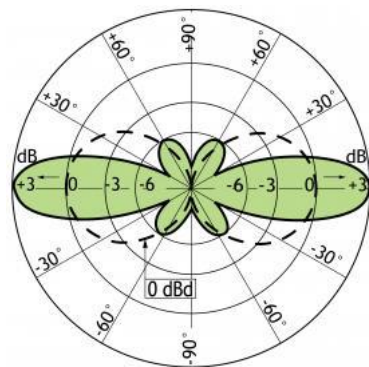

TYPICAL RADIATION PATTERN (H-PLANE)





CXL 1800-6/DECT

6 dBd Omdirectional Base Station and Marine Antenna for the DECT Band

- Vertically polarized, omnidirectional base station and marine antenna.
- Approximately 6 dBd gain.

DESCRIPTION

- The CXL 1800-6/DECT is especially suitable for the DECT band.
- To substantially reduce noise caused by atmospherical discharges, alle metal parts in the antenna are DC-grounded. Consequently, the antenna shows a DC-short across the coaxial cable.
- Simple mounting using the 1" revolving nut system.
- Wide variety of accessory mounting brackets available.

ORDERING DESIGNATIONS

TYPE	PRODUCT NO.
CXL 1800-6/DECT	100000189

SPECIFICATIONS

ELECTRICAL	
MODEL	1800-6/DECT
ANTENNA TYPE	Coaxial, collinear antenna
FREQUENCY	1880 - 1900 MHz (DECT)
IMPEDANCE	Nom. 50 Ω
POLARIZATION	Vertical
GAIN	8 dBi 6 dBd
BANDWIDTH	≤ 20 MHz @ SWR ≤ 1.5
SWR	≤ 1.5
MAX. POWER	100 W
ANTISTATIC PROTECTION	All metal parts DC-grounded (Connector shows a DC-short)
MECHANICAL	
TEMP. RANGE	-30°C \rightarrow +70°C
CONNECTOR	N-female

WIND SURFACE	Approx. 0.03 m ²
WIND LOAD	Approx. 38 N @ 160 km/h
COLOUR	Marine white
MATERIALS	Shroud: Polyurethane-coated glass fibre Mounting bracket: Chromed brass
TOTAL HEIGHT	Approx. 1.15 m
DIA. IN TOP END	21 mm
DIA. IN BOTTOM END	23 mm
WEIGHT	Approx. 700 g
MOUNTING	On 1" RG (G1"-11) threaded water pipe or on optional mounting brackets (see below)

ACCESSORIES (to be ordered separately)

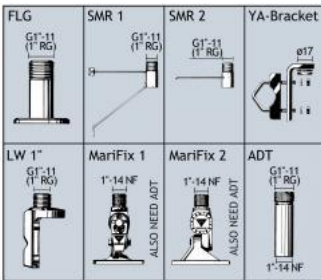

TYPICAL GAIN AND SWR CURVES

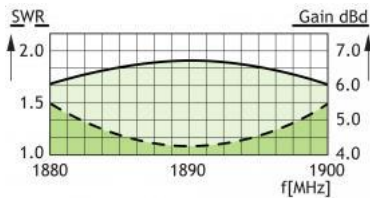

TYPICAL RADIATION PATTERN (E-PLANE)

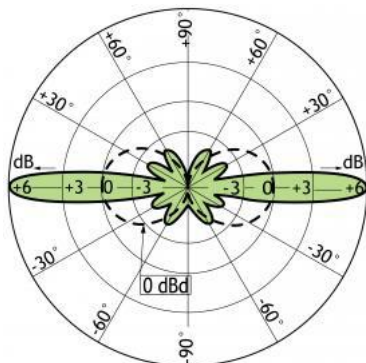

TYPICAL RADIATION PATTERN (H-PLANE)





CXL 2-2C

Unity Gain, Broad.Banded Base Station Antenna for the 160 MHz Band

- CXL 2-2C is a 0 dBd gain, omnidirectional base station antenna.
- The antenna covers the complete band: 144 - 175 MHz.

DESCRIPTION

- CXL 2-2C is designed for fixation on supporting tubes with outer diameter between 27 mm and 65 mm.
- The construction of the mount makes it possible to lead the cable either inside or along the outside of the mast tube.
- A glass fibre tube completely encloses the carefully designed radiating element to ensure long dependable service in all climates.
- Atmospheric discharges are immediately led to ground as all metal parts are DC-grounded (consequently, the antenna shows a DC-short across the coaxial cable).
- This antenna is used where reliability is of utmost importance. A long lifetime has been taken into consideration when designing this antenna - it is sturdy and strong.

ORDERING DESIGNATIONS

TYPE	PRODUCT NO.
CXL 2-2C	100000087

SPECIFICATIONS

ELECTRICAL	
MODEL	CXL 2-2C
ANTENNA TYPE	Coaxial, broad-band dipole
FREQUENCY	Covering: 144 - 175 MHz
IMPEDANCE	Nom. 50 Ω
RADIATION	Omnidirectional
POLARIZATION	Vertical
GAIN	2 dBi 0 dBd
BANDWIDTH	31 MHz
SWR	≤ 1.5
MAX. POWER	600 W
ANTISTATIC PROTECTION	All metal parts DC-grounded (Connector shows a DC-short)
MECHANICAL	

CONNECTOR	N-female
WIND SURFACE	0.091 m ²
WIND LOAD	115 N @ 160 km/h
COLOUR	Marine white
MATERIALS	Radome : Polyurethane-coated glass fibre Mast clamp : Seawater resistant aluminium, epoxy-coated
TOTAL HEIGHT	Approx. 1.75 m
WEIGHT	Approx. 3.0 kg
MOUNTING	On 27 - 65 mm dia. mast tube

TYPICAL GAIN AND SWR CURVES

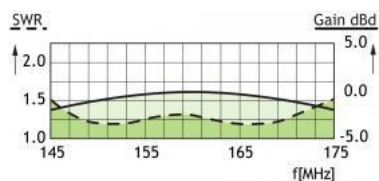

TYPICAL RADIATION PATTERN (E-PLANE)

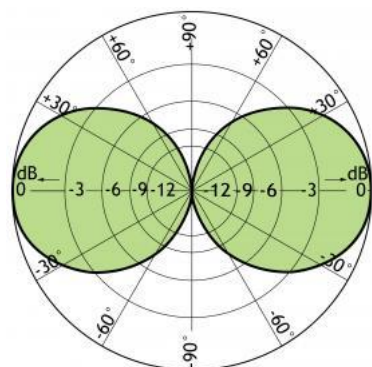

TYPICAL RADIATION PATTERN (H-PLANE)



MULTI-PURPOSE MOUNTING BRACKET

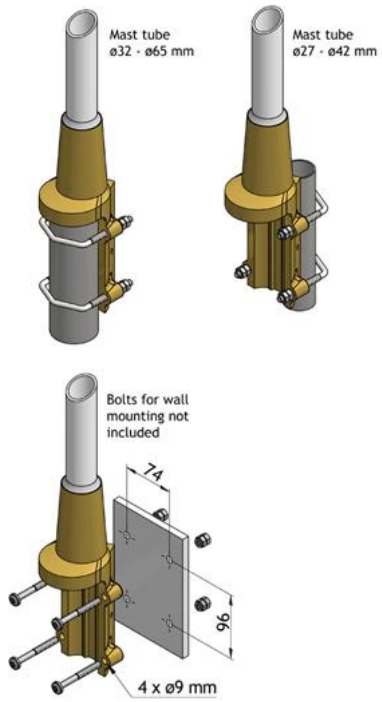



CXL 2-1LW/...

Universal, Unity-Gain Base Station and Marine Antenna for the 160 MHz Band

- This multi-purpose, omnidirectional, 0 dBd, rod-type base station and marine antenna covers the 160 MHz band in three models with 10 MHz overlap and can be used in a wide variety of applications.

DESCRIPTION

- The broad-banded $\frac{1}{2} \lambda$ dipole antenna element is sealed in a high-quality conical glass fibre tube with low wind-load, which will ensure undisturbed performance by corrosive environments.
- Provided with the sturdy "LW" mast mount - a lightweight, multipurpose, epoxy-coated mounting bracket made of non-corrosive aluminium.
- The accompanying U-bolts and fittings are made of stainless steel.
- To be mounted on vertical or horizontal mast tubes, 16 to 54 mm in outer diameter.
- The cable can be led either on the outside or along the inside of the mast tube.
- Large bandwidth with respect to both SWR and gain.
- CXL 2-1LW/... is DC-grounded to substantially reduce noise caused by atmospherical discharges and consequently shows a DC-short across the coaxial cable.
- The CXL 2-1LW/... is a vibration-proof, lightweight, slim-line, corrosion-resistant, modern style base station and marine antenna.
- For extreme marine environments, it is recommended to use the CXL 150-1LW-SS-R/....

ORDERING DESIGNATIONS

TYPE	PRODUCT NO.	FREQUENCY
CXL 2-1LW/s	110000296	138 - 156 MHz
CXL 2-1LW/l	110000082	146 - 165 MHz
CXL 2-1LW/h	110000080	155 - 175 MHz

SPECIFICATIONS

ELECTRICAL	
MODEL	CXL 2-1LW/...
ANTENNA TYPE	$\frac{1}{2} \lambda$ coaxial dipol, broad-banded
FREQUENCY	CXL 2-1LW/s: 138 - 156 MHz CXL 2-1LW/l: 146 - 165 MHz CXL 2-1LW/h: 155 - 175 MHz
IMPEDANCE	Nom. 50 Ω
RADIATION	Omnidirectional
POLARIZATION	Vertical

GAIN	2 dBi 0 dBd
BANDWIDTH	18 - 21 MHz depending on model
SWR	CXL 2-1/s: 138 - 156 MHz ≤ 1.5 CXL 2-1/l: 146 - 163 MHz ≤ 1.5 146 - 165 MHz ≤ 1.75 CXL 2-1/h: 156 - 175 MHz ≤ 1.5 155 - 175 MHz ≤ 1.75
MAX. POWER	150 W
ANTISTATIC PROTECTION	All metal parts DC-grounded (Connector shows a DC-short)
MECHANICAL	
TEMP. RANGE	-30°C → +70°C
CONNECTOR	N-female
WIND SURFACE	0.0172 m ²
WIND LOAD	22 N @ 160 km/h
MAX WIND SPEED	200 km/h
COLOUR	Marine white
MATERIALS	Shroud: Polyurethane-coated glass fibre Mounting bracket: Seawater resistant aluminium, epoxy-coated Clamps: Stainless steel
TOTAL HEIGHT	Approx. 1.3 m (Dep. on frequency)
DIA. IN TOP END	8 mm
DIA. IN BOTTOM END	16 mm
WEIGHT	Approx. 760 g
MOUNTING	On 16 to 54 mm dia. mast tube

TYPICAL GAIN AND SWR CURVES

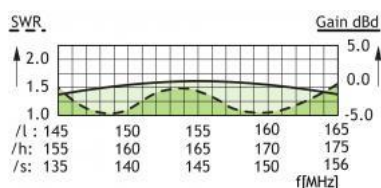

TYPICAL RADIATION PATTERN (E-PLANE)

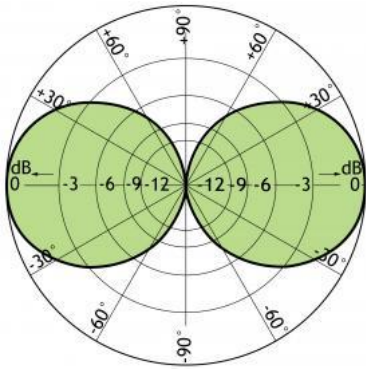

TYPICAL RADIATION PATTERN (H-PLANE)

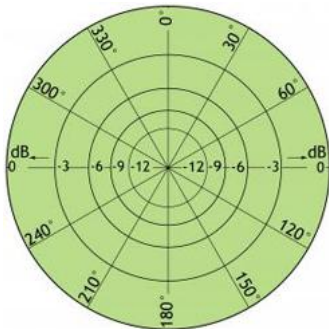

MULTI-PURPOSE MOUNTING BRACKET

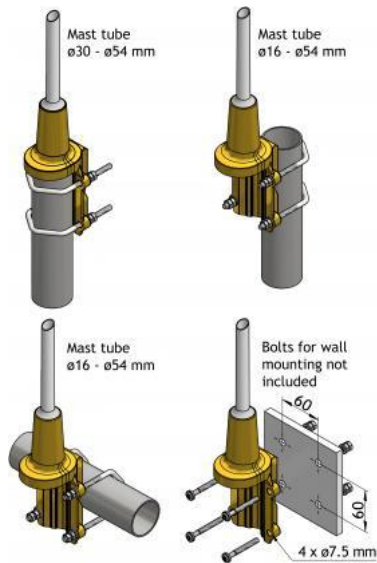

PLEASE NOTE

The antenna is delivered with a DC-connection between the antenna element and the mounting bracket.



CXL 2-1/...

Base Station and Marine VHF Antenna

- This base station and maritime VHF antenna is developed for use on board ships as well as on masts and thanks to the 1" revolving nut mounting system it can be mounted in the mast, in the auxiliary mast as well as on the cross-beam. By means of Procom's flange mount it can also be mounted on deck or rooftop.

DESCRIPTION

- Bear in mind that the higher the antenna is mounted the better coverage.
- Avoid mounting the antenna parallel with and in the neighbourhood of other metal parts, such as mast, supporting wires etc. Free mounting and as high as possible is most preferable, otherwise the SWR and the radiation diagram will be influenced.
- The antenna is a $\frac{1}{2} \lambda$ design and this means that it needs neither loading coils, ground-plane, radials nor other auxiliary arrangements.
- CXL 2-1/... can, without problems, operate with duplex radioes and on the semi-duplex channels, owing to the fact that it is broad-banded (see SWR diagram). In other words, CXL 2-1/... has a shipshape SWR on the RX-frequencies, which is just as important as it is for the TX-frequencies.
- Furthermore, the antenna is a grounded radiator antenna and therefore it shows a DC-short across the coaxial cable.
- A conical glass fibre tube completely encloses the carefully designed radiating element to assure long dependable service in all climates.

ORDERING DESIGNATIONS

TYPE	PRODUCT NO.	FREQUENCY	CONNECTOR
CXL 2-1/s CXL 2-1/l CXL 2-1/h	110000297 110000119 110000123	138 - 156 MHz 146 - 165 MHz 155 - 175 MHz	"UHF"-female
CXL 2-1/s-N CXL 2-1/l-N CXL 2-1/h-N	110000298 110000121 110000124	138 - 156 MHz 146 - 165 MHz 155 - 175 MHz	"N"-female
CXL 2-1/s-TNC CXL 2-1/l-TNC CXL 2-1/h-TNC	110000299 110000118 110000126	138 - 156 MHz 146 - 165 MHz 155 - 175 MHz	"TNC"-female

SPECIFICATIONS

ELECTRICAL	
MODEL	CXL 2-1/...
ANTENNA TYPE	$\frac{1}{2} \lambda$ coaxial dipol, broad-banded
FREQUENCY	CXL 2-1/s: 138 - 156 MHz CXL 2-1/l: 146 - 165 MHz CXL 2-1/h: 155 - 175 MHz
IMPEDANCE	Nom. 50 Ω

RADIATION	Omnidirectional
POLARIZATION	Vertical
GAIN	2 dBi 0 dBd
BANDWIDTH	18 - 21 MHz depending on model
SWR	CXL 2-1/s: 138 - 156 MHz ≤ 1.5 CXL 2-1/l: 146 - 163 MHz ≤ 1.5 146 - 165 MHz ≤ 1.75 CXL 2-1/h: 156 - 174 MHz ≤ 1.5 155 - 175 MHz ≤ 1.75
MAX. POWER	150 W
ANTISTATIC PROTECTION	All metal parts DC-grounded (Connector shows a DC-short)
MECHANICAL	
TEMP. RANGE	-30°C → +70°C
CONNECTOR	UHF-female (standard)
WIND SURFACE	0.018 m ²
WIND LOAD	25 N @ 160 km/h
MAX. WIND SPEED	Tested to 200 km/h
IP RATING	IP 66
COLOUR	Marine white
MATERIALS	Shroud: Polyurethane-coated glass fibre Mounting bracket: Chromed brass
TOTAL HEIGHT	Approx. 1.21 m
DIA. IN TOP END	8 mm
DIA. IN BOTTOM END	16 mm
WEIGHT	Approx. 300 g
MOUNTING	On 1" RG (G1" - 11) threaded water pipe or on optional mounting brackets (see below)

ACCESSORIES (to be ordered separately)

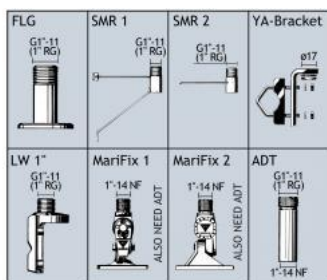

TYPICAL GAIN AND SWR CURVES

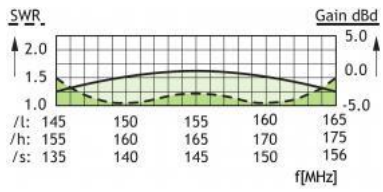

TYPICAL RADIATION PATTERN (E-PLANE)

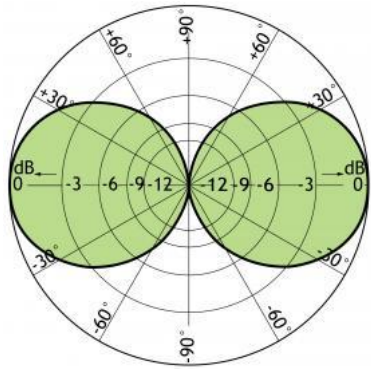

TYPICAL RADIATION PATTERN (H-PLANE)

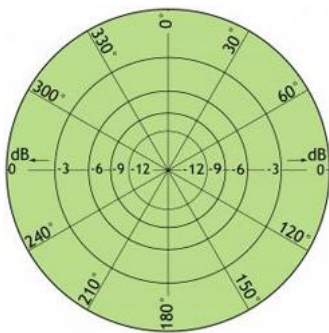



CXL 108-185C

0 dBi, Broad-Band Base Station and Marine Antenna for 108 - 185 MHz

- CXL 108-185C is a 0 dBi gain, omnidirectional base station and marine antenna.
- The antenna is extremely broad-banded and covers the complete band: 108 - 185 MHz.

DESCRIPTION

- CXL 108-185C is designed for fixation on supporting tubes with outer diameter between 27 mm and 65 mm.
- The construction of the mount makes it possible to lead the cable either inside or along the outside of the mast tube.
- A glass fibre tube completely encloses the carefully designed radiating element to ensure long dependable service in all climates.
- Atmospheric discharges are immediately led to ground as all metal parts are DC-grounded (consequently, the antenna shows a DC-short across the coaxial cable).
- This antenna is used where reliability is of utmost importance. A long lifetime has been taken into consideration when designing this antenna - it is sturdy and strong

ORDERING DESIGNATIONS

TYPE	PRODUCT NO.
CXL 108-185C	100000513

SPECIFICATIONS

ELECTRICAL	
MODEL	CXL 108-185C
ANTENNA TYPE	Coaxial, broad-band dipole
FREQUENCY	Covering: 108 - 185 MHz
IMPEDANCE	Nom. 50 Ω
RADIATION	Omnidirectional
POLARIZATION	Vertical
GAIN	0 dBi (see gain curve)
BANDWIDTH	77 MHz
SWR	≤ 2.5
MAX. POWER	40 W
ANTISTATIC PROTECTION	All metal parts DC-grounded (Connector shows a DC-short)

MECHANICAL	
TEMP. RANGE	-30° C → +70° C
CONNECTOR	N-female
WIND SURFACE	0.062 m ² / 0.67 feet ²
WIND LOAD	73 N @ 160 km/h / 99.42 mph.
MAX. WIND SPEED	200 km/h / 125 mph.
COLOUR	Marine white
MATERIALS	Radome : Polyurethane-coated glass fibre Mounting bracket: Seawater resistant aluminium, epoxy-coated
TOTAL HEIGHT	Approx. 1.64 m / 64.57 in.
WEIGHT	Approx. 3.5 kg / 7.72 lb.
MOUNTING	On 27 - 65 mm / 1.06 - 2.56 in. dia. mast tube

TYPICAL SWR CURVE



TYPICAL RADIATION PATTERN FOR 120 MHz (E-PLANE)

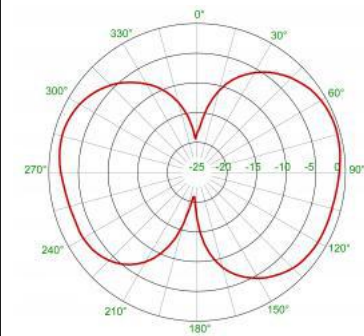

TYPICAL GAIN CURVE

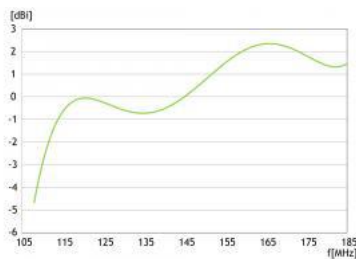

TYPICAL RADIATION PATTERN FOR 140 MHz (E-PLANE)

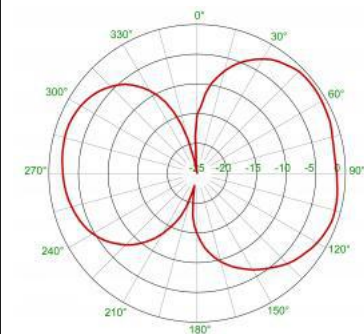

TYPICAL RADIATION PATTERN FOR 144 MHz (H-PLANE)

TYPICAL RADIATION PATTERN FOR 178 MHz (E-PLANE)

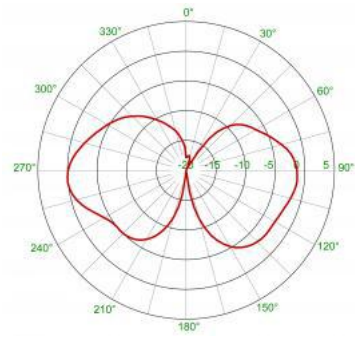
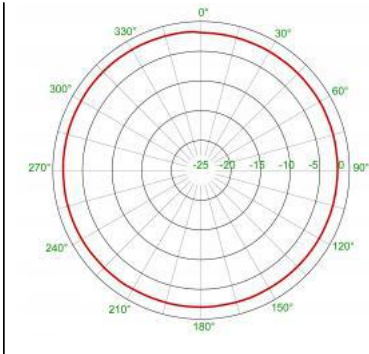

MULTI-PURPOSE MOUNTING BRACKET

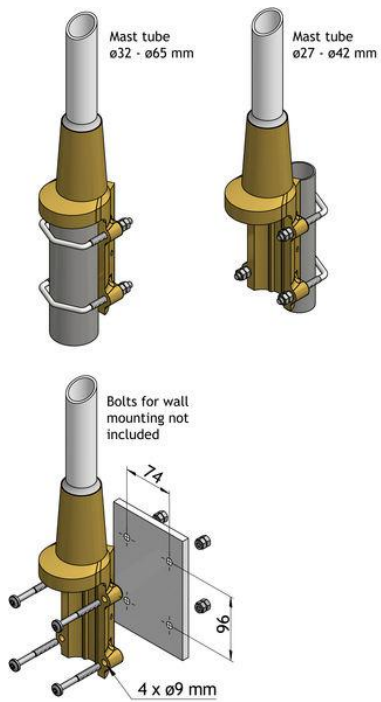

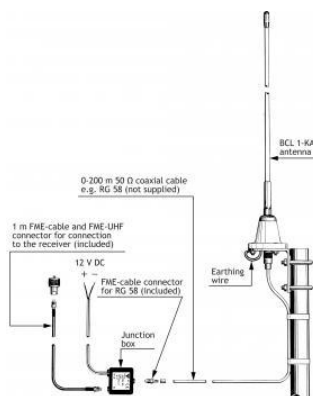

BCL 1-KA

Active Receiving Antenna for 10 kHz - 110 MHz

- This receiving antenna consists of a high-capacitance antenna element combined with an amplifier which is built into the antenna mount.
- The amplifier provides excellent impedance matching between the high-impedance antenna element and the 50 Ω downlead cable over an extremely wide bandwidth.

DESCRIPTION

- The amplifier is supplied with DC-power through the downlead 50 Ω coaxial cable by means of the supplied junction box which can be mounted in close vicinity to the receiving station. The junction box separates DC- and RF-signals and can advantageously be fed from the same DC-power supply as the receiver (if 12 V).
- The sensitivity of the amplifier is optimized so that noise generated in the antenna and the receiver is always less than noise picked up by the antenna. The amplifier is protected against RF-overload and violent discharges and the large dynamic range ensures excellent cross and intermodulation properties.
- The earthing wire (see drawing) ensures a low loss connection to ground for RF-signals and thereby also prevents noise pick-up from the ship's installations running on the outside of the coaxial cable. As the earthing wire is AC-coupled, electrolytic corrosion is effectively prevented.
- The junction box is protected against accidental polarity reversal and it is filtered to avoid interference pick-up.
- The junction box is provided with FME-connectors for the antenna and the receiver ports. 1 m FME-cable and an FME-UHF connector is included for connecting the box to the receiver as well as an FME-crimp connector for the downlead cable (RG 58).
- The antenna is designed to withstand the roughest of weather and climate conditions and it is perfectly suited also for marine purposes.
- The BCL 1-KA is supplied with the "SM-MA" mast mounting bracket.

ORDERING DESIGNATIONS

TYPE	PRODUCT NO.
BCL 1-KA	110000108

SPECIFICATIONS

ELECTRICAL	
MODEL	BCL 1-KA
ANTENNA TYPE	Broadband active receiving antenna
FREQUENCY	10 kHz - 110 MHz
IMPEDANCE	Nom. 50 Ω
POLARIZATION	Vertical

HORIZ. COVERAGE	Omni-directional
SUPPLY VOLTAGE	12 V DC (9 – 14 V)
CURRENT CONSUMP.	Approx. 60 mA
MAX. INTENSITY OF RECEIVED FIELD	Distortion due to amplifier voltage limitation occurs at field intensities exceeding 1.5 V/m
AERIAL PROTECTION	Spark gap
MECHANICAL	
TEMP. RANGE	-30° C → +60° C
CONNECTOR, ANT.	UHF (for PL 259)
CONNECTORS, JUNCTION BOX	Antenna: FME-connector (M) RX: FME-connector (M)
CABLE/CONNECTOR	1 m FME-cable and FME-UHF included. FME-cable connector for RG 58 downlead cable included
WIND SURFACE	0.0259 m ²
WIND LOAD	28.8 N @ 150 km/h
COLOUR	Marine white
MATERIALS	Shroud: Glass fibre and chromed brass MA housing: Lexan and chromed brass
TOTAL HEIGHT	Approx. 0.92 m (1.01 m incl. mounting bracket)
DIA. IN TOP END	7 mm
DIA. IN BOTTOM END	10 mm
WEIGHT	Approx. 600 g (800 g incl. mounting bracket)
MOUNTING	On 30 - 44 mm dia. mast tube or on a flat surface

FME-SYSTEM ACCESSORIES

FME-CABLES	
TYPE	PRODUCT NO.
1 m FME	130000437
2 m FME	130000447
3 m FME	130000457
4 m FME	130000466
5 m FME	130000474
6 m FME	130000483
4 m FME-white	110000064
6 m FME-white	110000066
12 m FME-white	110000068
18 m FME-white	110000069
FME-CONNECTORS	
TYPE	PRODUCT NO.

FME-FME	130000583
FME-P (Prolongation)	130000565
FME-N	130000571
FME-FSMA (Female-SMA)	130000578
FME-BNC	130000566
FME-TNC	130000569
FME-UHF	130000572
FME-MUHF (Mini-UHF)	130000573
FME-EMUHF (Elbow-MUHF)	130000582
FME-EBNC (Elbow-BNC)	130000580
FME-ETNC (Elbow-TNC)	130000581
FME-SMA	130000577

For further information about other types of FME-cables and FME-connectors, please compare the cable and connector data sheets under accessories in our catalogue.

INSTALLATION DETAILS - USING SM-MA MOUNTING BRACKET

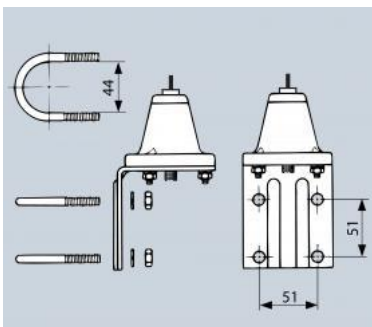

MOUNTING ON FLAT SURFACES

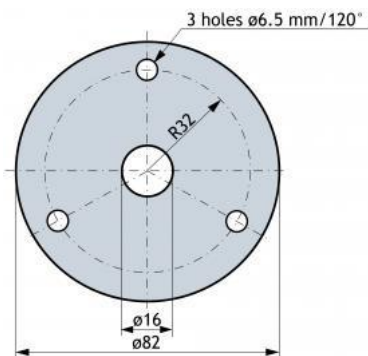

APPLICATION INFORMATION

The BCL 1-KA active receiving antenna is especially suitable for receiving of broadcast radio stations in the long wave, medium wave, short wave and FM (88 -108 MHz) radio bands.

However, as the whole frequency range from 10 kHz to 110 MHz is covered, the BCL 1-KA is also suitable as general purpose receiving antenna throughout the whole range.

Several advantages can be gained by using an active antenna instead of an ordinary wire antenna, especially in the lower frequency ranges. Firstly, the small physical size makes the active antenna much easier to install. Secondly, a wire antenna requires a matching unit which typically has narrow bandwidth, making retuning necessary when changing listening frequency.

The active wideband antenna BCL 1-KA is optimized throughout the whole covered frequency range. Thus, no tuning is required, making change of listening frequency much easier.

Considering that the active antenna yields signal to noise ratios and signal strengths normally only obtainable with much longer wire antennas, the BCL 1-KA makes a good choice, especially also with respect to economy.

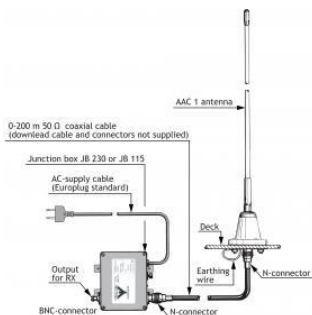

AAC 1/...

Active Receiving Antenna for 10 kHz - 110 MHz for Communication Purposes

- This active receiving antenna has been designed for professional use and special emphasis has been placed on obtaining a large dynamic range with excellent cross and intermodulation properties, a low noise figure and a secure protection against RF-overload and violent nearby discharges.

DESCRIPTION

- The AAC 1/... can be used either where superb listening quality is required or where a high RF-density environment exists, as for instance in connection with MF and HF duplex operation onboard ships, where nearby transmitting antennas may cause excessive field strengths. For complete safety the antenna should, however, not be mounted closer than 15 metres from transmitting antennas.
- The antenna consists of a high-capacitance glass fibre antenna element and an amplifier built into the antenna mount. The amplifier provides the necessary impedance matching between the high-impedance antenna element and the 50 Ω download cable over an extremely wide bandwidth.
- The necessary supply voltage (12 - 15 V DC) for the amplifier is delivered through the download coaxial cable from the junction box with mains power supply, type JB 230 (230 VAC) or JB 115 (115 VAC), which separates DC and RF-signals. Up to 200 m of RG 213/U coaxial cable can be used between antenna and junction box with only minor degrading effects.
- The earthing wire (see drawing) ensures a low loss connection to ground for RF-signals, and thereby also prevents noise pick-up from the ship's installations running on the outside of the coaxial cable. As the earthing wire is AC-coupled, electrolytic corrosion is effectively prevented.
- By careful choice of materials, the AAC 1/... is designed to withstand the roughest of climate conditions, ensuring many years of trouble-free service.
- Extended amplifier frequency range makes it possible also to receive FM-radio (88 - 108 MHz).

ORDERING DESIGNATIONS

TYPE	PRODUCT NO.
AAC 1/JB 230	100000160
AAC 1/JB 115	100000438
Junction box JB 230	110000009
Junction box JB 115	110000264

ANTENNA SPECIFICATIONS

ELECTRICAL	
MODEL	AAC 1/...
ANTENNA TYPE	Broadband active receiving antenna for communication purposes
FREQUENCY	10 kHz - 110 MHz
IMPEDANCE	Nom. 50 Ω
POLARIZATION	Vertical

HORIZONTAL COVER.	Omni-directional
ANTENNA FACTOR	Typ. 0.25 mV output in 50 Ω by a field strength of 1 mV/m
1 dB COMPRESSION POINT	Typ. occurring at a field strength of 1.5 V/m
1 dB QUIETING	Typ. occurring at a field strength of 1 V/m from an interfering signal
CROSS MODULATION	40 dB cross modulation attenuation typically occurring at a field strength of 0.7 V/m from an interfering source
INTERMODULATION	OIP ₂ > 40 dBm OIP ₃ > 27 dBm
MAX. ALLOWED FIELD STRENGTH	90 V/m
AMPLIFIER PROTECTION	Spark gap
OPERATING VOLTAGE	12 - 15 V DC (with JB 230 or JB 115)
CURRENT CONSUMP.	Approx. 60 mA
MECHANICAL	
TEMP. RANGE	-30° C → +60° C
CONNECTOR	N-female
WIND SURFACE	0.0259 m ²
WIND LOAD	28.8 N @ 150 km/h
COLOUR	Marine white
MATERIALS	Shroud: Glass fibre and chromed brass MA housing: Lexan amd chromed brass
TOTAL HEIGHT	Approx. 0.92 m / 36.22 in.
DIA. IN TOP END	7 mm / 0.28 in.
DIA. IN BOTTOM END	10 mm / 0.39 in.
WEIGHT	Approx. 600 g / 1.32 lb.
MOUNTING	On flat surfaces such as deck or roof or on 30 - 44 mm mast tube using accessory item "SM-MAS" (not included)

JUNCTION BOX / POWER SUPPLY

DETAILS	
MODELS	JB 230 (230 V) JB 115 (115 V)
SUPPLY VOLTAGE	230 V or 115 V AC, 50 - 60 Hz (please refer to ordering designations)
DC-VOLTAGE FOR ANTENNA	15 V unloaded, approx. 12 - 15 V with antenna
POWER CONSUMPTION	Approx. 7.5 W
TEMP. RANGE	-30° C → +60° C
CONNECTORS	In: N-female Out: BNC-female
"ON" INDICATOR	Red LED

FUSE	5 x 20 mm 50 mA/250 V Antisurge (JB 230) 100 mA/250 V Antisurge (JB 115)
SUPPLY CABLE	1.5 m, unterminated
MATERIAL	Aluminium
SURFACE TREATMENT	Light-grey vinyl painted
WEIGHT	Approx. 650 g / 1.43 lb.
DIMENSIONS (W x D x H)	120 x 130 x 59 mm / 4.72 x 5.12 x 2.32 in. (connectors included)

BOX INSTALLATION DETAILS

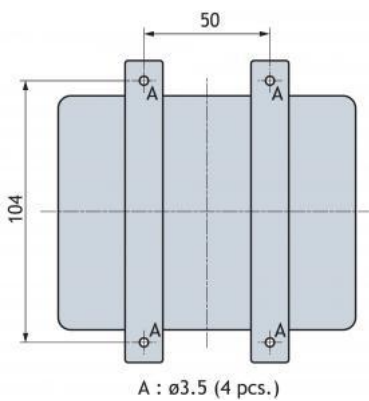

MOUNTING ON FLAT SURFACES

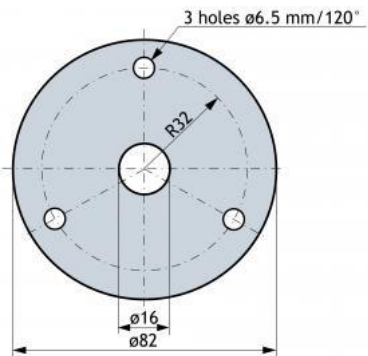



CXL VHF/GSM

2-Band Marine Antenna Covering Marine VHF and 900 MHz Cellular (GSM, NMT-900)

- Covers 155 – 162 MHz (marine VHF) and 890 – 960 MHz (GSM and NMT-900) with 0 dBd gain on both bands.
- Mounting using standard marine 1” revolving nut system.

Description

- The existing antenna can easily be replaced – the downlead cable may be reused.
- Saves space and weight in the masthead.
- Performs much better than two antennas (often mounted too close to each other – thereby destroying each other’s performance).
- Only one downlead cable necessary – saves additional weight. RG 213 recommended for lowest cable loss on both bands.
- Mount the antenna as high as possible and unobstructed by metal objects.
- Optional splitting filter (diplexer) type DIPX 225/330 available to connect the two radio telephones to the downlead cable.
- Wide range of accessory mounting brackets available (See accessories tab).

ORDERING DESIGNATIONS

TYPE NO.	PRODUCT NO.
CXL VHF/GSM	110000127

SPECIFICATIONS

ELETRICAL	
MODEL	CXL VHF/GSM
ANTENNA TYPE	Dual-frequency coaxial antenna
FREQUENCY	Marine VHF: 155 – 162 MHz GSM/NMT: 890 – 960 MHz
IMPEDANCE	Nom. 50 Ω
RADIATION	Omnidirectional
POLARIZATION	Vertical
GAIN	Marine VHF: 2 dBi 0 dBd GSM/NMT: 2 dBi 0 dBd
SWR (Both Bands)	TX: ≤ 1.5 RX: ≤ 2.5
MAX. POWER	100 W
ANTISTATIC PROTECTION	All metal parts DC-grounded (Shows a DC-short at the connector)

MECHANICAL	
TEMP. RANGE	-30°C → +70°C
MATERIALS	Shroud: Polyurethane coated glass fibre Mounting bracket: Chromed brass
CONNECTOR	N-female
WIND SURFACE	Approx. 0.013 m ²
WIND LOAD	Approx. 15 N @ 150 km/h
COLOUR	Marine white
TOTAL HEIGHT	Approx. 1.1 m
DIA. IN TOP END	8 mm
DIA. IN BOTTOM END	16 mm
WEIGHT	Approx. 400 g
MOUNTING	On 1" RG (G1"-11) threaded pipe or on optional mounting brackets (see below). Revolving nut enclosed

FME-SYSTEM ACCESSORIES

FME-CABLES	
TYPE	PRODUCT NO.
1 m FME	130000437
2 m FME	130000447
3 m FME	130000457
4 m FME	130000466
5 m FME	130000474
6 m FME	130000483
4 m FME-white	110000064
6 m FME-white	110000066
12 m FME-white	110000068
18 m FME-white	110000069
FME-CONNECTORS	
TYPE	PRODUCT NO.
FME-FME	130000583
FME-P (Prolongation)	130000565
FME-N	130000571
FME-FSMA (Female-SMA)	130000578

FME-BNC	130000566
FME-TNC	130000569
FME-UHF	130000572
FME-MUHF (Mini-UHF)	130000573
FME-EMUHF (Elbow-MUHF)	130000582
FME-EBNC (Elbow-BNC)	130000580
FME-ETNC (Elbow-TNC)	130000581
FME-SMA	130000577

For further information about other types of FME-cables and FME-connectors, please compare the cable and connector data sheets under accessories.



ACCESSORIES

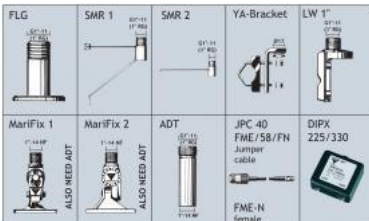

(To be ordered separately)



CXL 900-1/...

Unity Gain Base Station and Marine 900 MHz Antenna for Mounting on Threaded 1

- The CXL 900-1/... is a 0 dBd, vertically polarized, omnidirectional rod-type base station and marine antenna which covers the 900 MHz band in three models.
- The 1" revolving nut mounting system is standard throughout the base station or maritime sector, and several different mounting brackets are available, making it possible to install the antenna either on the masthead using FLG or SMR 2, side mounted on the mast (SMR 1) or mounted on a cross-beam (FLG). Also, the antenna can be mounted on deck or rooftop by means of the FLG.

DESCRIPTION

- CXL 900-1/... is especially suitable for use in connection with 900 MHz CELLULAR systems - as for instance the Nordic Mobile Telephone system NMT 900 - making it possible to extend the normally land-based cellular telephone system for maritime mobile service as well.
- The higher the antenna is mounted, the better coverage. Avoid mounting the antenna parallel with or in the neighbourhood of other metal parts, such as masts, supporting wires etc., otherwise the SWR and the radiation pattern may be strongly influenced.
- To substantially reduce noise caused by atmospheric discharges, all metal parts in the antenna are DC-grounded. Consequently, the antenna shows a DC-short across the coaxial cable.
- A conical glass fibre tube completely encloses the carefully designed radiating element to ensure long dependable service in all climates.

ORDERING DESIGNATIONS

TYPE	PRODUCT NO.	FREQUENCY
CXL 900-1/l	110000146	824 - 894 MHz
CXL 900-1/m	110000145	870 - 950 MHz
CXL 900-1/h	110000144	890 - 960 MHz

SPECIFICATIONS

ELECTRICAL	
MODEL	CXL 900-1/...
ANTENNA TYPE	$\frac{1}{2} \lambda$ coaxial dipole, broad-banded
FREQUENCY	Models within 824 - 960 MHz
IMPEDANCE	Nom. 50 Ω
POLARIZATION	Vertical
GAIN	2 dBi 0 dBd
BANDWIDTH	70 - 80 MHz
SWR	≤ 1.5
MAX. POWER	100 W
MECHANICAL	

TEMP. RANGE	-30°C → +70°C
CONNECTOR	N-female
WIND SURFACE	Approx. 0.0070 m ²
WIND LOAD	Approx. 9 N @ 160 km/h
COLOUR	Marine white
MATERIALS	Shroud: Polyurethane-coated glass fibre Mounting bracket: Chromed brass
TOTAL HEIGHT	Approx. 420 mm
DIA. IN TOP END	12 mm
DIA. IN BOTTOM END	16 mm
WEIGHT	Approx. 350 g
MOUNTING	On 1" RG (G1"-11) threaded water pipe or on optional mounting brackets (see below)

ACCESSORIES (to be ordered separately)

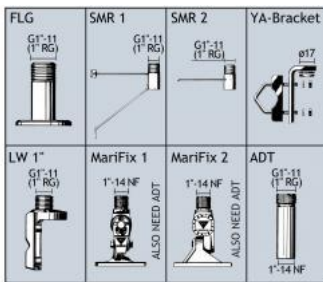

TYPICAL GAIN AND SWR CURVES

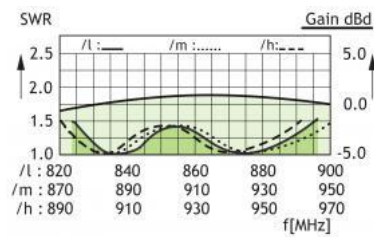

TYPICAL RADIATION PATTERN (E-PLANE)

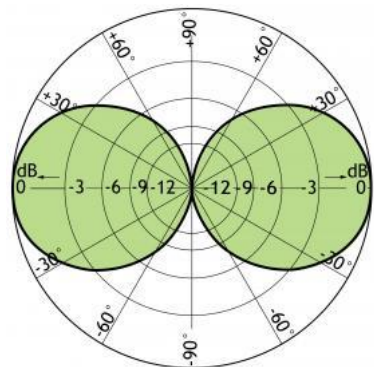

TYPICAL RADIATION PATTERN (H-PLANE)

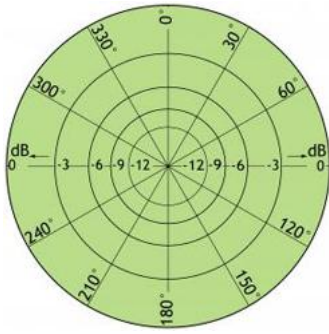

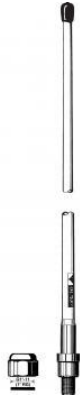

CXL 900-3/...

3 dBd Gain, Base Station and Marine 900 MHz Antenna for Mounting on Threaded 1" Water Pipe

- CXL 900-3/... is a 3 dBd, vertically polarized, omnidirectional rod-type base station and marine antenna which covers the 900 MHz band in four models.
- The 1" revolving nut mounting system is standard throughout the base station or maritime sector, and several different mounting brackets are available, making it possible to install the antenna either on the masthead using FLG or SMR 2, side-mounted on the mast (SMR 1), or mounted on a cross-beam (FLG). Also, the antenna can be mounted on deck or rooftop by means of the FLG. (See below).

Description

- CXL 900-3/... is especially suitable for use in connection with 900 MHz CELLULAR systems - making it possible to extend the normally land-based cellular telephone system for maritime mobile service as well.
- The phasing of the radiating elements is adjusted to yield maximum gain in the horizontal plane, with the level of the sidelobes reduced to a minimum.
- The higher the antenna is mounted, the better coverage. Avoid mounting the antenna parallel to or in the neighbourhood of other metal parts, such as masts, supporting wires etc., otherwise the SWR and the radiation pattern may be strongly influenced.
- To substantially reduce noise caused by atmospherical discharges, all metal parts in the antenna are DC-grounded. Consequently, the antenna shows a DC-short across the coaxial cable.
- A conical glass fibre tube completely encloses the carefully designed radiating element to ensure long dependable service in all climates.

ORDERING DESIGNATIONS

TYPE	PRODUCT NO.	FREQUENCY
CXL 900-3/II	110000363	750 - 830 MHz
CXL 900-3/I	110000149	824 - 894 MHz
CXL 900-3/m	110000150	870 - 950 MHz
CXL 900-3/h	110000148	890 - 960 MHz

SPECIFICATIONS

ELECTRICAL	
MODEL	CXL 900-3/...
ANTENNA TYPE	Collinear, broad-banded
FREQUENCY	Models within 750 - 960 MHz
IMPEDANCE	Nom. 50 Ω
POLARIZATION	Vertical
GAIN	5 dBi 3 dBd
BAND WIDTH	70 - 80 MHz
SWR	≤ 1.5

MAX. POWER	100 W
MECHANICAL	
TEMP. RANGE	-30°C → +70°C
CONNECTOR	N-female
WIND SURFACE	Approx. 0.0096 m ²
WIND LOAD	12 N @ 160 km/h
COLOUR	Marine white
MATERIALS	Shroud: Polyurethane-coated glass fibre Mounting bracket: Chromed brass
TOTAL HEIGHT	Approx. 630 mm
DIA. IN TOP END	12 mm
DIA. IN BOTTOM END	16 mm
WEIGHT	Approx. 380 g
MOUNTING	On 1" RG (G1"-11) threaded water pipe or on optional mounting brackets (see below)

ACCESSORIES (to be ordered separately)

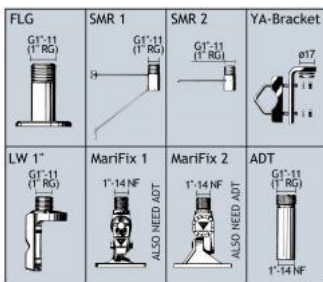

TYPICAL GAIN AND SWR CURVES

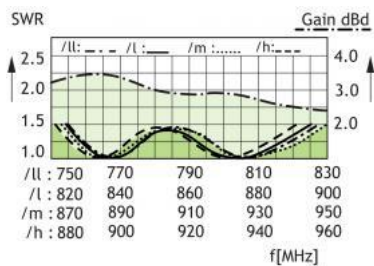

TYPICAL RADIATION PATTERN (E-PLANE)

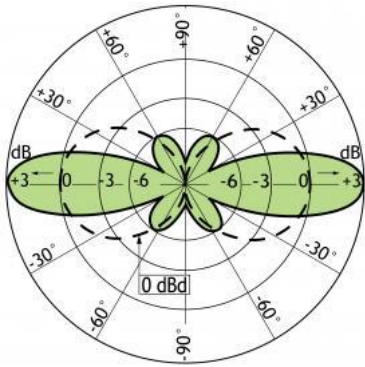

TYPICAL RADIATION PATTERN (H-PLANE)



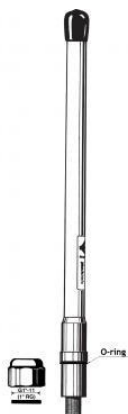

CXL 900/1800/1900/UMTS

Quadruple-Band Base Station and Marine Antenna for the 900 MHz, 1800 MHz, 1900 MHz and the 2000 MHz Bands

- Quadruple-Band base station and marine antenna – four bands with only one antenna.
- Covering both GSM/NMT-900, DCS-1800/PCN (GSM 900/1800) PCS-1900 and UMTS.

Description

- Particularly suitable for use with triple-band mobile phones.
- Unity gain on all bands.
- Simple mounting using the 1" revolving nut system.
- Wide variety of accessory mounting brackets available.

ORDERING DESIGNATIONS

TYPE	PRODUCT NO.
CXL 900/1800/1900/UMTS	110000230

SPECIFICATIONS

ELECTRICAL	
MODEL	CXL 900/1800/1900/UMTS
ANTENNA TYPE	Quadruple-Band base station and marine antenna
FREQUENCY	800-960 MHz/1710-1880 MHz/1850-1990 MHz/ 1900-2200 MHz (GSM 900/DCS-1800/PCS-1900/UMTS)
IMPEDANCE	Nom. 50 Ω
POLARIZATION	Vertical
GAIN	Approx. 0 dBi
SWR	GSM @ ≤ 2.0 DCS-1800 @ ≤ 2.0 PCS-1900 @ ≤ 3.0 UMTS @ ≤ 3.0
MAX. POWER	100 W
MECHANICAL	
TEMP. RANGE	-30°C → +70°C
CONNECTOR	N-female
WIND SURFACE	Approx. 0.013 m ²

WIND LOAD	Approx. 17 N @ 160 km/h
MAX WIND SPEED	200 km/h
COLOUR	Marine white
MATERIALS	Shroud: Polyurethane-coated glass fibre Mounting bracket: Chromed brass
TOTAL HEIGHT	Approx. 450 mm
DIA. IN TOP END	21 mm
DIA. IN BOTTOM END	23 mm
WEIGHT	Approx. 300 g
MOUNTING	On 1" RG (G1" - 11) threaded water pipe or on optional mounting brackets (see below)

ACCESSORIES (to be ordered separately)

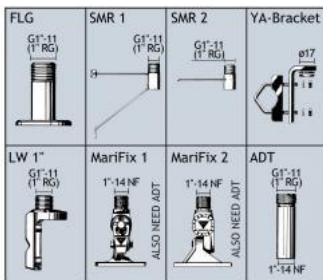

TYPICAL RADIATION PATTERN (E-PLANE)

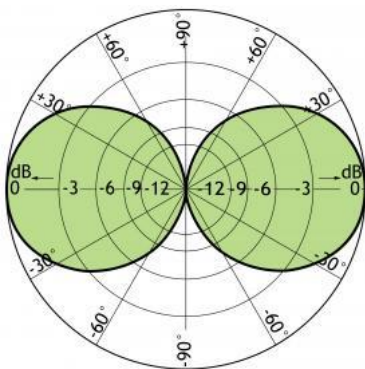

TYPICAL RADIATION PATTERN (H-PLANE)

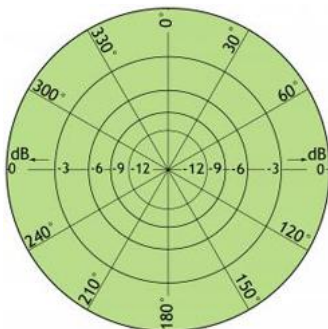



CXL 70-3LW/...

Lightweight, Medium Duty, 3 dBd Base Station and Marine Antenna for the 450 MHz Band

- CXL 70-3LW/... is a 3 dBd, vertically polarised, omnidirectional base station and marine antenna, which covers the UHF band in 4 models with up to 10 MHz overlap.
- The antenna meets the demand for a medium duty, cost-effective antenna to be chosen, when the exceptional mechanical capabilities of our extremely rugged heavy-duty model CXL 70-3C/... are not needed.

DESCRIPTION

- The carefully designed radiating element is sealed in a high-quality, conical glass fibre tube with low wind-load, which will ensure performance undisturbed by corrosive environments.
- Provided with the sturdy "LW" mast mount - a lightweight, multipurpose, epoxy-coated mounting bracket made of non-corrosive aluminium.
- The accompanying U-bolts and fittings are made of stainless steel.
- To be mounted on vertical or horizontal mast tubes, 16 to 54 mm in outer diameter.
- The cable can be led either on the outside or along the inside of the mast tube.
- Large bandwidth with respect to both SWR and gain.
- To substantially reduce noise caused by atmospherical discharges, all metal parts in the antenna are DC-grounded. Consequently, the antenna shows a DC-short across the coaxial cable.
- The CXL 70-3LW/... is a vibration-proof, lightweight, slim-line, corrosion resistant, modern style base station and marine antenna.

ORDERING DESIGNATIONS

TYPE	PRODUCT NO.	FREQUENCY
CXL 70-3LW/s	110000092	380 - 410 MHz
CXL 70-3LW/f	110000088	406 - 430 MHz
CXL 70-3LW/l	110000091	420 - 450 MHz
CXL 70-3LW/h	110000089	440 - 470 MHz

SPECIFICATIONS

ELECTRICAL	
MODEL	CXL 70-3LW/...
ANTENNA TYPE	Collinear, broad-banded
FREQUENCY	30 MHz wide frequency segments within 380 - 470 MHz. See model survey.
IMPEDANCE	Nom. 50 Ω
RADIATION	Omnidirectional
POLARIZATION	Vertical
GAIN	5 dBi 3 dBd

HALFPOWER BEAMWIDTH	30°
BANDWIDTH	30 MHz
SWR	≤ 1.5
MAX. POWER	150 W
ANTISTATIC PROTECTION	All metal parts DC-grounded (Connector shows a DC-short)
MECHANICAL	
TEMP. RANGE	-35°C → +70°C
CONNECTOR	N-female
WIND SURFACE	0.026 m ²
WIND LOAD	33 N @ 160 km/h
COLOUR	Marine white
MATERIALS	Shroud: Polyurethane-coated glass fibre Mounting bracket: Seawater resistant aluminium, epoxy-coated Clamps: Stainless steel
TOTAL HEIGHT	Approx. 1.4 m (dep. on freq.)
DIA. IN TOP END	16 mm
DIA. IN BOTTOM END	23 mm
WEIGHT	Approx. 1.3 kg
MOUNTING	On 16 to 54 mm dia. mast tube

TYPICAL GAIN AND SWR CURVES

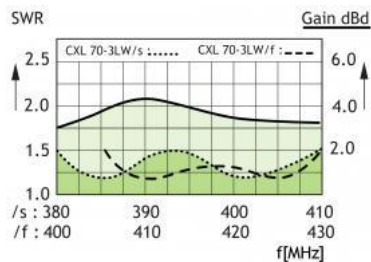

TYPICAL GAIN AND SWR CURVES

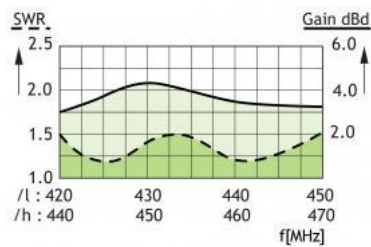

TYPICAL RADIATION PATTERN (E-PLANE)

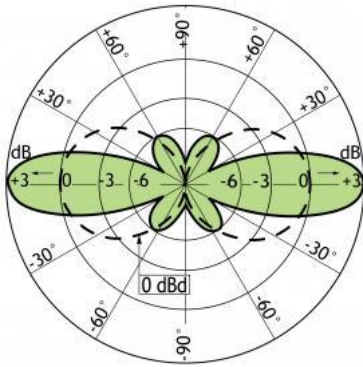

TYPICAL RADIATION PATTERN (H-PLANE)

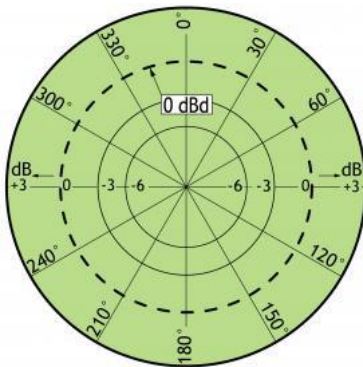

MULTI-PURPOSE MOUNTING BRACKET

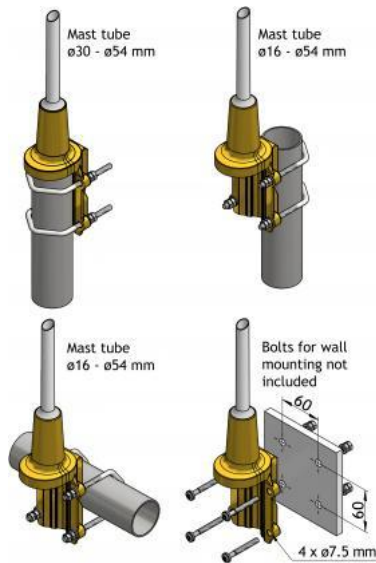

PLEASE NOTE

The antenna is delivered with a DC-connection between the antenna element and the mounting bracket.



CXL 450-6HD/T-X/...

Sturdy, 6 dBd, Omnidirectional lightning protected Base Station Antenna for 450 MHz Bands

- CXL 450-6HD/T-X/... is a 6 dBd, vertically polarized, omnidirectional base station antenna for 450 MHz bands with three models.
- The antenna has been approved to withstand lightning.

DESCRIPTION

- The antenna is provided with our sturdy type "HD" mast mount - a heavy-duty, multipurpose mounting bracket made of non-corrosive aluminium. The accompanying U-bolts and fittings are made of stainless steel.
- The antenna can be mounted on mast tubes of 58 to 105 mm in outer diameter. Furthermore, the construction of the mount makes it possible to lead the cable either along the inside or on the outside of the mast tube.
- The antenna element is sealed in a high-quality, cylindrical glass fibre tube, ensuring undisturbed performance in all climates.
- To substantially reduce noise caused by atmospherical discharges, all metal parts in the antenna are DC-grounded. Consequently, the antenna shows a DC-short across the coaxial cable.
- CXL 450-6HD/T-X/... is a vibration-proof, slim-line, corrosion-resistant, modern style base station antenna.
- The centre fed dipole design and feed network gives a stable radiation pattern across a wide bandwidth, and allows tilted beam designs to be effectively employed without large pattern distortions.

ORDERING DESIGNATIONS

TYPE	PRODUCT NO.	FREQUENCY	TILT
CXL 450-6HD/T-0/l	100000653	340 - 370 MHz	0°
CXL 450-6HD/T-0/m	100000654	380 - 430 MHz	0°
CXL 450-6HD/T-0/h	100000655	420 - 470 MHz	0°
CXL 450-6HD/T-6/l	100000656	340 - 370 MHz	6°
CXL 450-6HD/T-6/m	100000657	380 - 430 MHz	6°
CXL 450-6HD/T-6/h	100000658	420 - 470 MHz	6°
CXL 450-6HD/T-8/l	100000659	340 - 370 MHz	8°
CXL 450-6HD/T-8/m	100000660	380 - 430 MHz	8°
CXL 450-6HD/T-8/h	100000661	420 - 470 MHz	8°
CXL 450-6HD/T-12/l	100000662	340 - 370 MHz	12°
CXL 450-6HD/T-12/m	100000663	380 - 430 MHz	12°
CXL 450-6HD/T-12/h	100000664	420 - 470 MHz	12°

SPECIFICATIONS

ELECTRICAL	
MODEL	CXL 450-6HD/T-X/...

ANTENNA TYPE	Medium-gain collinear
FREQUENCY	340 - 470 MHz
IMPEDANCE	Nom. 50 Ω
RADIATION	Omnidirectional
POLARIZATION	Vertical
GAIN	8 dBi 6 dBd
HALF POWER BEAMWIDTH	16°
SWR	≤ 1.5
MAX. POWER	300 W
ANTISTATIC PROTECTION	All metal parts DC-grounded (Connector shows a DC-short)
AVAILABLE BEAMTILTS	0, 6, 8 and 12°
PIM	-153 dBc @ 2x43 dBm
MECHANICAL	
TEMP. RANGE	-30°C to +70°C
CONNECTOR	7/16 DIN female
WIND SURFACE	0.166 m ²
WIND LOAD	236.7 N @ 160 km/h
WIND VELOCITY	Tested to 200 km/h
COLOUR	Marine white
MATERIALS	Radome: Polyurethane-coated glass fibre Mounting bracket: Seawater resistant aluminium, polyester-coated
TOTAL HEIGHT	Approx. 2.92 m, 115 Inch
WEIGHT	Approx. 8.5 kg, 19 lb
MOUNTING	On 58 - 105 mm dia. mast tube

MULTI-PURPOSE MOUNTING BRACKET

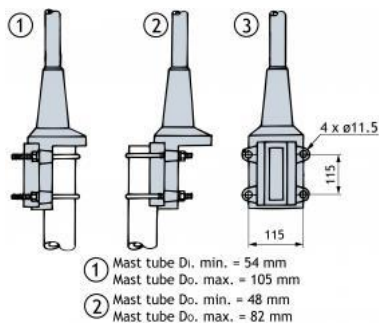



CXL 70-3C/...

Collinear, 3 dBd Base Station and Marine Antenna for the 450 MHz Band

- CXL 70-3C/... is a 3 dBd, vertically polarized, omnidirectional base station and marine antenna, which covers the 380 – 470 MHz band in 4 models with up to 10 MHz overlap.
- The antenna is provided with our “C” universal fixation bracket made of epoxy-coated, seawater resistant aluminium. The accompanying U-bolts and fittings are made of stainless steel.

DESCRIPTION

- CXL 70-3C/... can be mounted on 27 to 65 mm dia. mast tubes, and it is possible to lead the cable either along the inside or on the outside of the mast tube.
- The carefully designed radiating element is sealed in a high-quality, conical glass fibre tube with low wind-load, which will ensure performance undisturbed by corrosive environments.
- To substantially reduce noise caused by atmospherical discharges, all metal parts in the antenna are DC-grounded. Consequently, the antenna shows a DC-short across the coaxial cable.
- The exceptional mechanical capabilities of this antenna ensures long dependable service in all environments.

ORDERING DESIGNATIONS

TYPE	PRODUCT NO.	FREQUENCY
CXL 70-3C/s	100000113	380 – 410 MHz
CXL 70-3C/f	100000109	406 – 430 MHz
CXL 70-3C/l	100000112	420 – 450 MHz
CXL 70-3C/h	100000110	440 – 470 MHz

SPECIFICATIONS

ELECTRICAL	
MODEL	CXL 70-3C/...
ANTENNA TYPE	Collinear, broad-banded
FREQUENCY	30 MHz wide frequency segments within 380 – 470 MHz. See model survey.
IMPEDANCE	Nom. 50 Ω
RADIATION	Omnidirectional
POLARIZATION	Vertical
GAIN	5 dBi 3 dBd
HALF POWER BEAMWIDTH	30°
BANDWIDTH	30 MHz

SWR	≤ 1.5
MAX. POWER	150 W
ANTISTATIC PROTECTION	All metal parts DC-grounded (Connector shows a DC-short)
MECHANICAL	
TEMP. RANGE	-30°C → +70°C
CONNECTOR	N-female
WIND SURFACE	0.032 m ²
WIND LOAD	40 N @ 160 km/h
COLOUR	Marine white
MATERIALS	Shroud: Polyurethane-coated glass fibre Mounting bracket: Seawater resistant aluminium, epoxy-coated Clamps: Stainless steel
TOTAL HEIGHT	Approx. 1.45 m (dep. on freq.)
DIA. IN TOP END	16 mm
DIA. IN BOTTOM END	25 mm
WEIGHT	Approx. 2.4 kg
MOUNTING	On 27 - 65 mm dia. mast tube

TYPICAL GAIN AND SWR CURVES

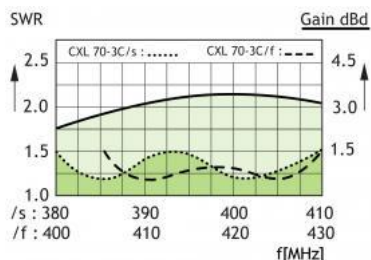

TYPICAL GAIN AND SWR CURVES

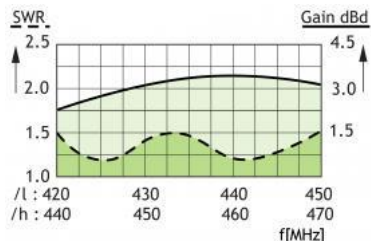

TYPICAL RADIATION PATTERN (E-PLANE)

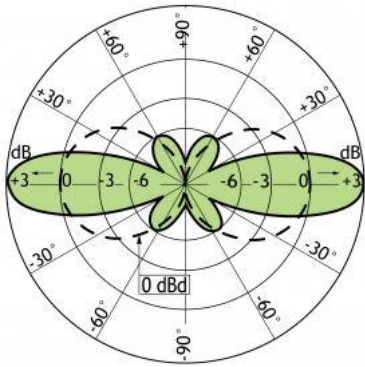

TYPICAL RADIATION PATTERN (H-PLANE)



MULTI-PURPOSE MOUNTING BRACKET

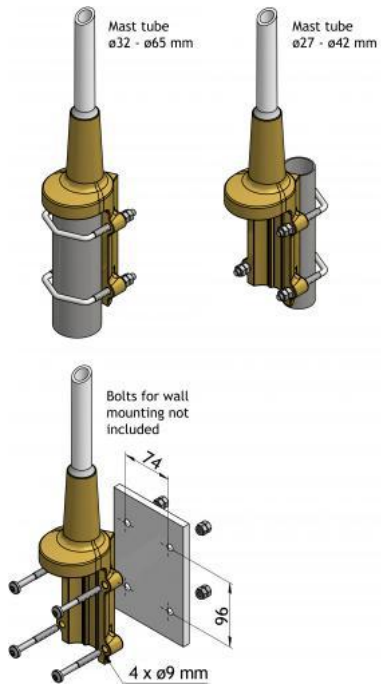



G-CXL 2-2C

Universal, Unity-Gain Base Station and Marine Antenna for the 160 MHz Band. Designed for defense units.

- G-CXL 2-2C is a 0 dBd gain, omnidirectional base station antenna. The antenna covers the complete band: 144 - 175 MHz.
- G-CXL 2-2C is designed for fixation on supporting tubes with outer diameter between 27 mm and 65 mm.

DESCRIPTION

- The construction of the mount makes it possible to lead the cable either inside or along the outside of the mast tube.
- A glass fibre tube completely encloses the carefully designed radiating element to ensure long dependable service in all climates.
- Atmospheric discharges are immediately led to ground as all metal parts are DC-grounded (consequently, the antenna shows a DC-short across the coaxial cable).
- This antenna is used where reliability is of utmost importance. A long lifetime has been taken into consideration when designing this antenna - it is sturdy and strong.

ORDERING DESIGNATIONS

TYPE	PRODUCT NO.
G-CXL 2-2C	100000267

SPECIFICATIONS

ELECTRICAL	
MODEL	G-CXL 2-2C
ANTENNA TYPE	Coaxial, broad-band dipole
FREQUENCY	Covering: 144 - 175 MHz
IMPEDANCE	Nom. 50 Ω
RADIATION	Omnidirectional
POLARIZATION	Vertical
GAIN	2 dBi 0 dBd
BANDWIDTH	31 MHz
SWR	≤ 1.5
MAX. POWER	600 W
ANTISTATIC PROTECTION	All metal parts DC-grounded (Connector shows a DC-short)
MECHANICAL	
CONNECTOR	N-female
WIND SURFACE	0.091 m ²

WIND LOAD	115 N @ 160 km/h
COLOUR	Green
MATERIALS	Shroud: Polyurethane-coated glass fibre Mast clamp : Seawater resistant aluminium, black
TOTAL HEIGHT	Approx. 1.75 m
WEIGHT	Approx. 3.0 kg
MOUNTING	On 27 - 65 mm dia. mast tube

TYPICAL GAIN AND SWR CURVES

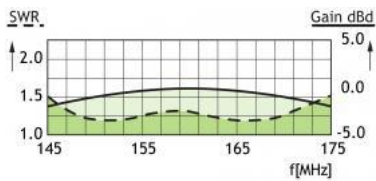

TYPICAL RADIATION PATTERN (E-PLANE)

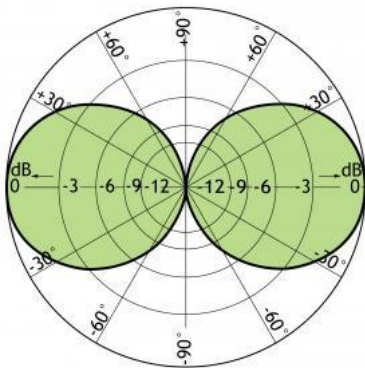

TYPICAL RADIATION PATTERN (H-PLANE)

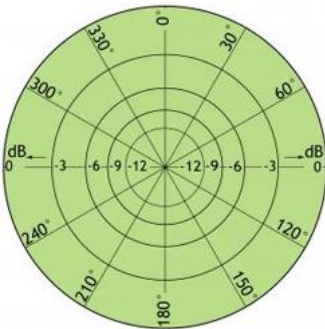

MULTI-PURPOSE MOUNTING BRACKET

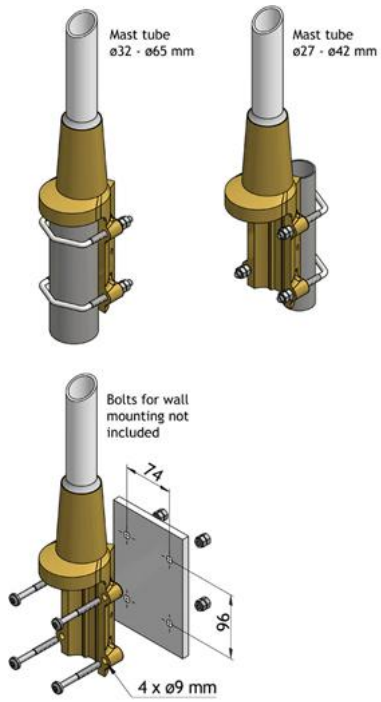

PLEASE NOTE

The antenna is delivered with a DC-connection between the antenna element and the mounting bracket.



G-CXL 2-1LW/...

Universal, Unity-Gain Base Station and Marine Antenna for the 160 MHz Band. Designed for defense units.

- This multi-purpose, omnidirectional, 0 dBd, rod-type base station and marine antenna covers the 160 MHz band in two models with 10 MHz overlap and can be used in a wide variety of applications.
- The broad-banded $\frac{1}{2} \lambda$ dipole antenna element is sealed in a high-quality conical glass fibre tube with low wind-load, which will ensure undisturbed performance by corrosive environments.

DESCRIPTION

- Provided with the sturdy "LW" mast mount - a lightweight, multipurpose, epoxy-coated mounting bracket made of non-corrosive aluminium.
- The cable can be led either on the outside or along the inside of the mast tube.
- Large bandwidth with respect to both SWR and gain.
- G-CXL 2-1LW/... is DC-grounded to substantially reduce noise caused by atmospherical discharges and consequently shows a DC-short across the coaxial cable.

ORDERING DESIGNATIONS

TYPE	PRODUCT NO.	FREQUENCY
G-CXL 2-1LW/l	110000185	146 - 165 MHz
G-CXL 2-1LW/h	110000186	155 - 175 MHz

SPECIFICATIONS

ELECTRICAL	
MODEL	G-CXL 2-1LW/...
ANTENNA TYPE	$\frac{1}{2} \lambda$ coaxial dipol, broad-banded
FREQUENCY	G-CXL 2-1LW/l: 146 - 165 MHz G-CXL 2-1LW/h: 155 - 175 MHz
IMPEDANCE	Nom. 50 Ω
RADIATION	Omnidirectional
POLARISATION	Vertical
GAIN	2 dBi 0 dBd
BANDWIDTH	20 MHz
SWR	CXL 2-1/l: 146 - 163 MHz \leq 1.5 146 - 165 MHz \leq 1.75 CXL 2-1/h: 156 - 174 MHz \leq 1.5 155 - 175 MHz \leq 1.75
MAX. POWER	150 W
ANTISTATIC PROTECTION	All metal parts DC-grounded (Connector shows a DC-short)

MECHANICAL	
TEMP. RANGE	-30°C → +70°C
CONNECTOR	N-female
WIND SURFACE	0.019 m ²
WIND LOAD	27 N @ 160 km/h
MAX. WIND SPEED	Tested to 200 km/h
IP RATING	IP 66
COLOUR	Green
MATERIALS	Shroud: Polyurethane-coated glass fibre Mounting bracket: Seawater resistant aluminium, epoxy-coated Clamps: Stainless steel
TOTAL HEIGHT	Approx. 1.28 m (Dep. on frequency)
DIA. IN TOP END	8 mm
DIA. IN BOTTOM END	16 mm
WEIGHT	Approx. 760 g
MOUNTING	On 16 to 54 mm dia. mast tube

TYPICAL GAIN AND SWR CURVES

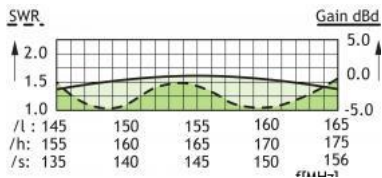

TYPICAL RADIATION PATTERN (E-PLANE)

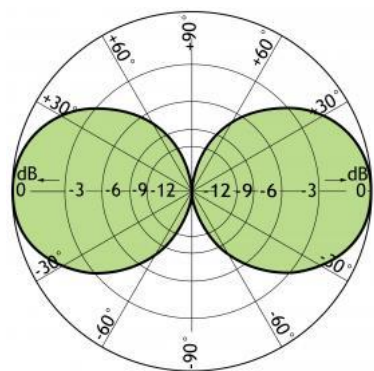

TYPICAL RADIATION PATTERN (H-PLANE)



MULTI-PURPOSE MOUNTING BRACKET

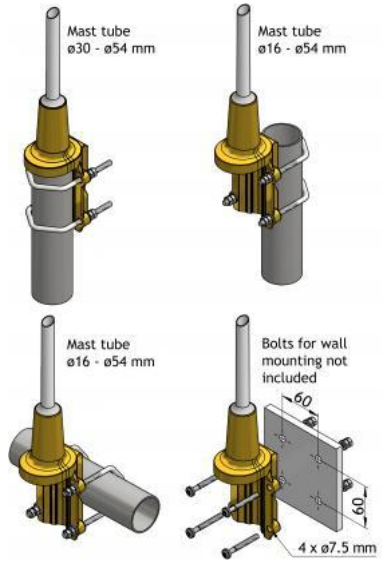



CXL 5700-6

6 dBd Omnidirectional Base Station and Marine Antenna for the 5700 MHz Band

- Vertically polarized, omnidirectional base station and marine antenna.
- Approximately 6 dBd gain.

DESCRIPTION

- Wide variety of accessory mounting brackets available.
- Highly suitable for duplex operation with large spacing between the TX and the RX frequencies.
- The antenna element is sealed in a high-quality, conical glass fibre tube.
- The CXL 5700-6 is a vibration-proof, lightweight, slim-line, corrosion resistant, modern style base station and marine antenna.

ORDERING DESIGNATIONS

TYPE	PRODUCT NO.
CXL 5700-6	100000291

SPECIFICATIONS

ELECTRICAL	
MODEL	CXL 5700-6
ANTENNA TYPE	Coaxial, collinear antenna, broad-banded with 3 - 5° electrical downtilt
FREQUENCY	5450 - 5750 MHz
IMPEDANCE	Nom. 50 Ω
POLARIZATION	Vertical
GAIN	8 dBi 6 dBd
BANDWIDTH	≥ 300 MHz @ SWR ≤ 2.0
SWR	≤ 2.0
MAX. POWER	100 W
ANTISTATIC PROTECTION	All metal parts DC-grounded (Connector shows a DC-short)
MECHANICAL	
TEMP. RANGE	-30°C → +70°C

CONNECTOR	N-female
WIND SURFACE	Approx. 0.007 m ²
WIND LOAD	Approx. 10 N @ 160 km/h
COLOUR	Marine white
MATERIALS	Shroud: Polyurethane-coated glass fibre Mounting bracket: Chromed brass
TOTAL HEIGHT	Approx. 378 mm
DIA. AT TOP END	13 mm
DIA. AT BOTTOM END	16 mm
WEIGHT	Approx. 200 g
MOUNTING	On 1" RG (G1"-11) threaded water pipe or on optional mounting brackets

ACCESSORIES (to be ordered separately)

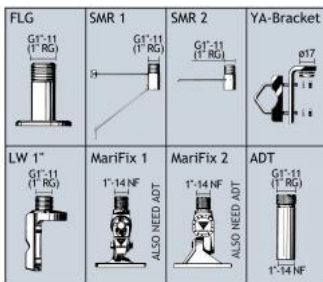

TYPICAL GAIN AND SWR CURVES

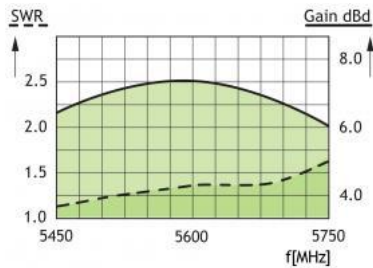

TYPICAL RADIATION PATTERN (E-PLANE)

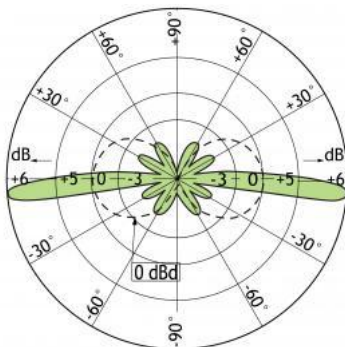

TYPICAL RADIATION PATTERN (H-PLANE)

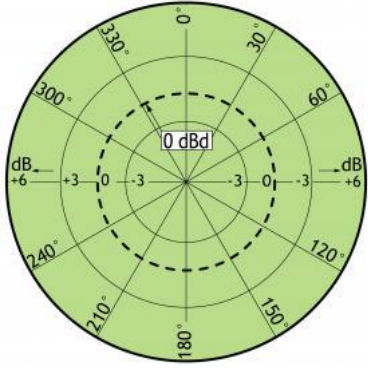



CXL 5700-3

3 dBd Omnidirectional Base Station and Marine Antenna for the 5700 MHz Band

- Vertically polarized, omnidirectional base station and marine antenna.
- Approximately 3 dBd gain.

DESCRIPTION

- Simple mounting using the 1" revolving nut system.
- Wide variety of accessory mounting brackets available.
- Large bandwidth with respect to both SWR and gain.
- Highly suitable for duplex operation with large spacing between the TX and the RX frequencies.
- The antenna element is sealed in a high-quality, conical glass fibre tube.
- All metal parts in the antenna are DC-grounded to reduce the noise caused by atmospherical discharge. Consequently, the antenna shows a DC-short across the coaxial cable.
- The CXL 5700-3 is a vibration-proof, lightweight, slim-line, corrosion resistant, modern style base station and marine antenna.

ORDERING DESIGNATIONS

TYPE	PRODUCT NO.
CXL 5700-3	100000199

SPECIFICATIONS

ELECTRICAL	
MODEL	CXL 5700-3
ANTENNA TYPE	Coaxial, collinear antenna, broad-banded
FREQUENCY	5450 - 5900 MHz
IMPEDANCE	Nom. 50 Ω
POLARIZATION	Vertical
GAIN	5 dBi 3 dBd
BANDWIDTH	≥ 450 MHz @ SWR ≤ 2.0
SWR	≤ 1.5
MAX. POWER	100 W
ANTISTATIC PROTECTION	All metal parts DC-grounded (Connector shows a DC-short)
MECHANICAL	

TEMP. RANGE	-30°C → +70°C
CONNECTOR	N-female
WIND SURFACE	Approx. 0.005 m ²
WIND LOAD	Approx. 6 N @ 160 km/h
COLOUR	Marine white
MATERIALS	Shroud: Polyurethane-coated glass fibre Mounting bracket: Chromed brass
TOTAL HEIGHT	Approx. 230 mm
DIA. IN TOP END	14 mm
DIA. IN BOTTOM END	16 mm
WEIGHT	Approx. 200 g
MOUNTING	On 1" RG (G1"-11) threaded water pipe or on optional mounting brackets

ACCESSORIES (to be ordered separately)

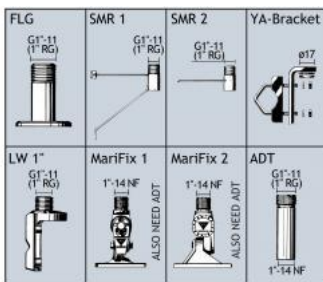

TYPICAL GAIN AND SWR CURVES

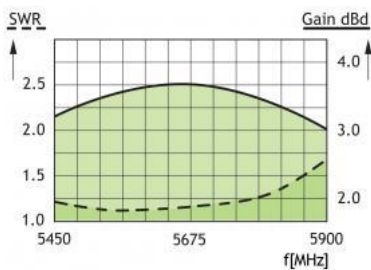

TYPICAL RADIATION PATTERN (E-PLANE)

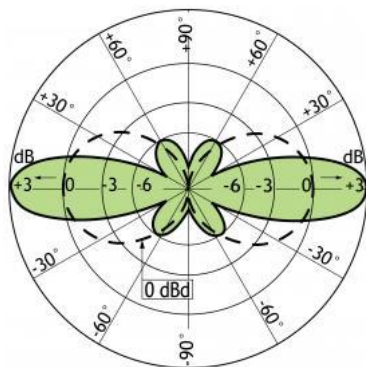

TYPICAL RADIATION PATTERN (H-PLANE)





CXL 5200-6LW

6 dBd Omnidirectional Base Station and Marine Antenna for the 5200 MHz Band

- Vertically polarized, omnidirectional base station and marine antenna.
- Approximately 6 dBd gain.

DESCRIPTION

- Highly suitable for duplex operation with large spacing between the TX and the RX frequencies.
- The antenna element is sealed in a high-quality, conical glass fibre tube.
- All metal parts in the antenna are DC-grounded to reduce the noise caused by atmospherical discharge. Consequently, the antenna shows a DC-short across the coaxial cable.
- The CXL 5200-6LW is a vibration-proof, lightweight, slim-line, corrosion resistant, modern style base station and marine antenna.

ORDERING DESIGNATIONS

TYPE	PRODUCT NO.
CXL 5200-6LW	100000296

SPECIFICATIONS

ELECTRICAL	
MODEL	CXL 5200-6LW
ANTENNA TYPE	Coaxial, collinear antenna, broad-banded
FREQUENCY	5150 - 5250 MHz
IMPEDANCE	Nom. 50 Ω
POLARIZATION	Vertical
GAIN	8 dBi 6 dBd
BANDWIDTH	≥ 100 MHz @ SWR ≤ 1.5
SWR	≤ 1.5
MAX. POWER	35 W
ANTISTATIC PROTECTION	All metal parts DC-grounded (Connector shows a DC-short)

MECHANICAL	
TEMP. RANGE	-30°C → +70°C
CONNECTOR	N-female
WIND SURFACE	Approx. 0.009 m ²
WIND LOAD	Approx. 12 N @ 160 km/h
COLOUR	Marine white
MATERIALS	Shroud: Polyurethane-coated glass fibre Mounting bracket: Chromed brass
TOTAL HEIGHT	Approx. 530 mm
DIA. AT TOP END	13 mm
DIA. AT BOTTOM END	16 mm
WEIGHT	Approx. 520 g
MOUNTING	On 16 to 54 mm dia. mast tube

TYPICAL GAIN AND SWR CURVES

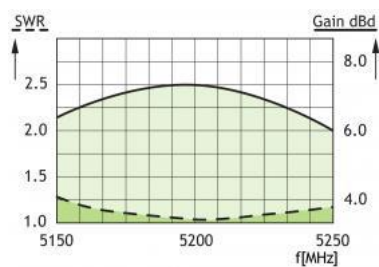

TYPICAL RADIATION PATTERN (E-PLANE)

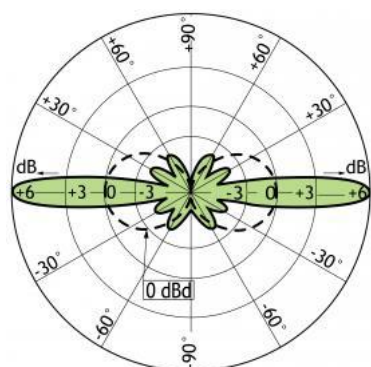

TYPICAL RADIATION PATTERN (H-PLANE)

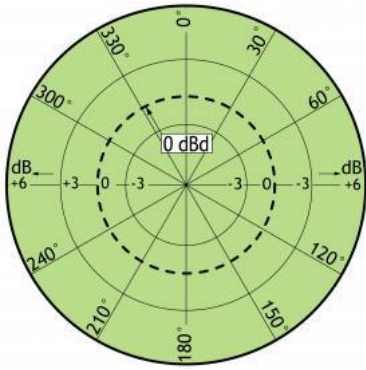

MULTI-PURPOSE MOUNTING BRACKET

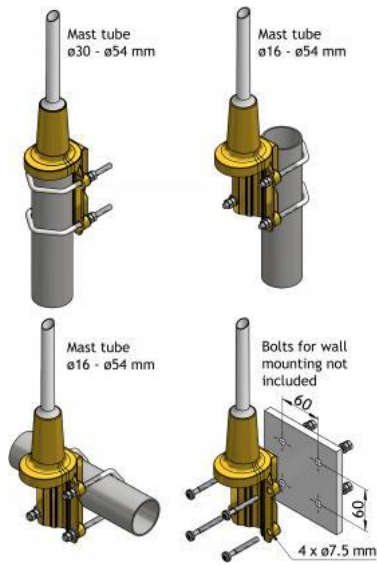



CXL 5700-1/...

Unity Gain Base Station and Marine 5700 MHz Antenna for Mounting on Threaded 1

- The CXL 5700-1/... is a 0 dBd, vertically polarized, omnidirectional rod-type base station and marine antenna for the 5700 MHz band.

DESCRIPTION

- The 1" revolving nut mounting system is standard throughout the marine sector, and several different mounting brackets are available, making it possible to install the antenna either on the masthead using FLG or SMR 2, side-mounted on the mast (SMR 1) or mounted on a cross-beam (FLG). Also, the antenna can be mounted on deck or rooftop by means of the FLG.
- The higher the antenna is mounted, the better coverage. Avoid mounting the antenna parallel to or in the neighbourhood of other metal parts, such as masts, supporting wires etc., otherwise the SWR and the radiation pattern may be strongly influenced.
- A conical glass fibre tube completely encloses the carefully designed radiating element to ensure long dependable service in all climates.

ORDERING DESIGNATIONS

TYPE	FREQUENCY	PRODUCT NO.
CXL 5700-1/l	5150 - 5350 MHz	100000285
CXL 5700-1/m	5300 - 5500 MHz	100000286
CXL 5700-1/h	5450 - 5900 MHz	100000198

SPECIFICATIONS

ELECTRICAL	
MODEL	CXL 5700-1/...
ANTENNA TYPE	$\frac{1}{2} \lambda$ coaxial dipole, broad-banded
FREQUENCY	Models within 5150 - 5900 MHz
IMPEDANCE	Nom. 50 Ω
POLARIZATION	Vertical
GAIN	2 dBi 0 dBd
BANDWIDTH	≥ 300 MHz @ SWR ≤ 2.0
SWR	≤ 2.0 , typ. ≤ 1.5

MAX. POWER	100 W
MECHANICAL	
CONNECTOR	N-female
WIND SURFACE	Approx. 0.006 m ²
WIND LOAD	Approx. 8 N @ 160 km/h
COLOUR	Marine white
MATERIALS	Shroud: Polyurethane-coated glass fibre Mounting bracket: Chromed brass
TOTAL HEIGHT	Approx. 230 mm
DIA. IN TOP END	14 mm
DIA. IN BOTTOM END	16 mm
WEIGHT	Approx. 180 g
MOUNTING	On 1" RG (G1"-11) threaded water pipe or on optional mounting brackets (see below)
ENVIRONMENTAL	
TEMP. RANGE	-30°C → +70°C

ACCESSORIES (to be ordered separately)

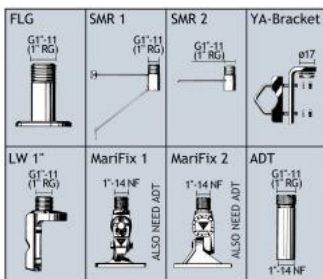

TYPICAL GAIN AND SWR CURVES

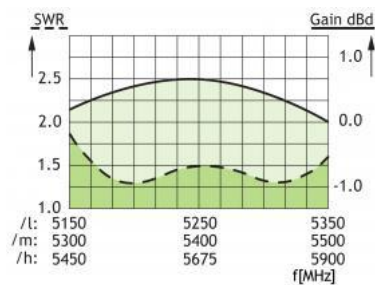

TYPICAL RADIATION PATTERN (E-PLANE)

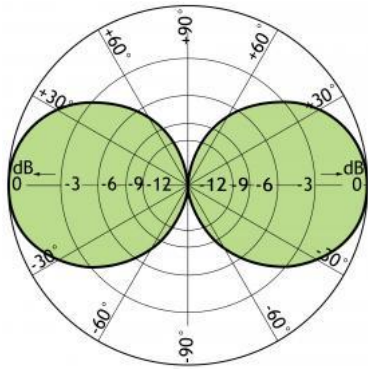

TYPICAL RADIATION PATTERN (H-PLANE)

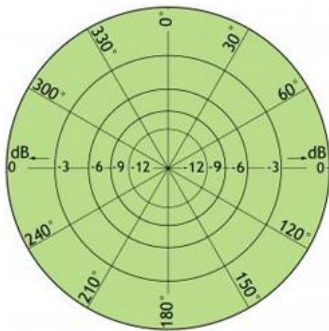



BPF 2/...-250

Band-Pass Filters for the 150 MHz Band

- High power base station band-pass filters for the 140 - 175 MHz range.
- The use of large $\varnothing 250$ mm cavities means a high Q, resulting in a very narrow passband.

DESCRIPTION

- The large dimensions also mean a high power rating.
- Unloaded Q of a single cavity is approx. 8000.
- High frequency stability on temperature and power.
- 19" mounting brackets are available as an option.

ORDERING DESIGNATIONS

TYPE	PRODUCT NO.
BPF 2/1-250	200000954
BPF 2/2-250	200000964
BPF 2/3-250	200000971

SPECIFICATIONS

ELECTRICAL			
MODEL	BPF 2/1-250	BPF 2/2-250	BPF 2/3-250
FREQ. RANGE	140 - 175 MHz	140 - 175 MHz	140 - 175 MHz
MAX. INPUT POWER	350 W @ 0.5 dB IL 150 W @ 2.0 dB IL	350 W @ 1.0 dB IL 150 W @ 4.0 dB IL	350 W @ 1.5 dB IL 150 W @ 6.0 dB IL
INSERTION LOSS	Adjustable 0.4 - 2.0 dB	Adjustable 0.8 - 4.0 dB	Adjustable 1.2 - 6.0 dB
IMPEDANCE	Nom. 50 Ω	Nom. 50 Ω	Nom. 50 Ω
SWR	< 1.5	< 1.5	< 1.5
MECHANICAL			
TEMP. RANGE RH 0-90% non-condensing	-30° C → +60° C	-30° C → +60° C	-30° C → +60° C
FREQ. STABILITY	Approx. 1.5 ppm/° C	Approx. 1.5 ppm/° C	Approx. 1.5 ppm/° C
CONNECTORS	N-female	N-female	N-female
DIMENSIONS	$\varnothing 250$ x 600 mm	L:250 x W:500 x H:600 mm	L:250 x W:750 x H:600 mm
WEIGHT	Approx. 4.3 kg	Approx. 8.9 kg	Approx. 14 kg

TYPICAL RESPONSE CURVES

Figure 1

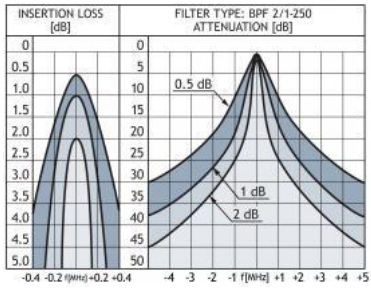

Figure 2

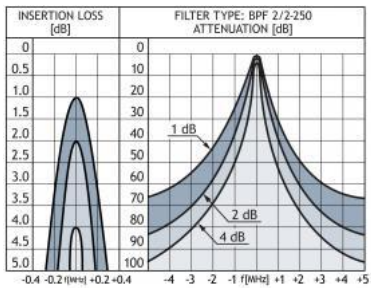
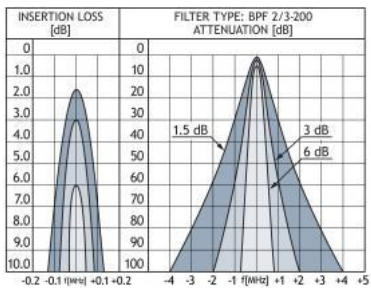
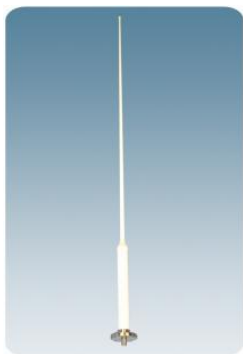

Figure 3





AIS 2/GPS 4

Dual Band Antenna for the AIS system

- This active antenna has been designed for use by the Universal Shipborne Automatic Identification System (AIS) on all waterways.
- The antenna consists of a high-performance glass fibre encapsulated antenna element and an active GPS antenna.
- The latter is built into the bottom part of the antenna together with a diplex filter. Only one down lead cable is therefore necessary.

DESCRIPTION

- The antenna element is a $1/2 \lambda$ antenna for the maritime VHF frequency range 156 - 162.5 MHz.
- The GPS antenna has a full hemispherical coverage and a built-in high-gain, low-noise amplifier.
- The necessary supply voltage (5 V DC) for the amplifier is delivered through the down lead coaxial cable. Up to 30 m of RG 214/U coaxial cable can be used between the antenna and the receiver/transceiver.
- By careful choice of materials, the AIS 2/GPS 4 is designed to withstand the roughest of climate conditions, ensuring many years of trouble-free service.

ORDERING DESIGNATIONS

TYPE NO.	PRODUCT NO.
AIS 2/GPS 4-N	112000039
DM Mounting Kit	112000001
SM-MAS	110000196
DIPX 1000/1550 N-DC-H	200000749
PRO-DIPX 1000/1550 N-DC-H	200000799

SPECIFICATIONS

ELECTRICAL VHF	
MODEL	AIS 2/GPS 4
ANTENNA TYPE	$1/2 \lambda$ antenna element
FREQUENCY	156 - 162.5 MHz
IMPEDANCE	Nom. 50 Ω
POLARIZATION	Vertical
GAIN	Approx. 2 dBi 0 dBd
SWR	Typ. < 1.5
MAX. POWER	25 W
ELECTRICAL GPS	
ANTENNA TYPE	Quadrifilar Helix Active antenna
FREQUENCY	1575 MHz

IMPEDANCE	Nom. 50 Ω
POLARIZATION	Circular right-hand
COVERAGE	Hemispherical
GAIN (in axial direction)	> 32 dBi
CROSS POLARIZATION ATT	> 10 dB (typ.)
Built-in Amplifier	
GAIN	> 30 dB (typ.)
NOISE FIGURE	< 3 dB (typ.)
P ₁ dB	Approx. +10 dBm
SWR (output)	\leq 2.0
SUPPLY VOLTAGE	5 \pm 0.5 V DC (3 V and 12 V respectively available on request)
SELECTIVITY	> 20 dB down @ \pm 100 MHz
CURRENT CONSUMPTION	Approx. 44 mA
MECHANICAL	
TEMP. RANGE	-30° C \rightarrow + 70° C
CONNECTOR	N-female
WIND SURFACE	Approx. 0.031 m ²
WIND LOAD	Approx. 50 N @ 160 km/h
COLOUR	Marine white

MATERIALS Shroud : Polyurethane coated glass fibre
Flange : Chromed brass

TOTAL HEIGHT	Approx. 1350 mm
WEIGHT	Approx. 900 g
MOUNTING	On 30-44 mm mast tube using stainless steel clamp type SM-MAS or on deck using DM Mounting Kit



Standard Mounting Kit included.



DM Mounting Kit for Deck Mount to be ordered separately

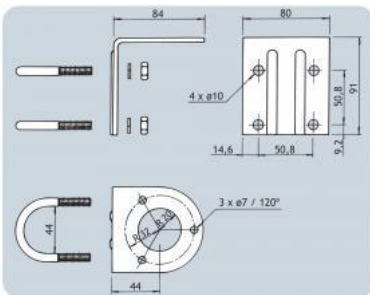

SM-MAS Mounting Kit for Side Mount and Mast Mount to be ordered separately.

MOUNTING ON FLAT SURFACES

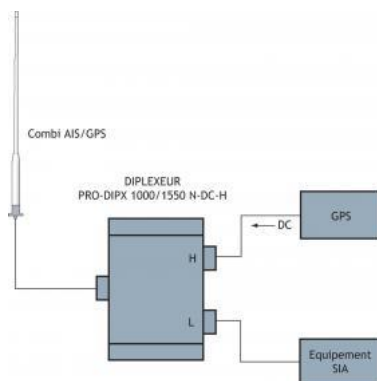
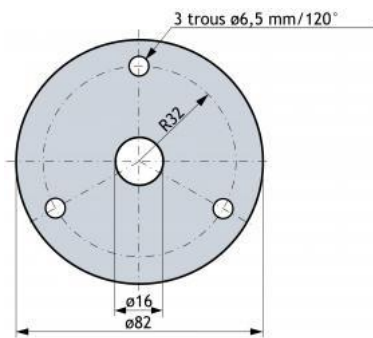

Alternatively, DIPLEXER DIPX 1000/1550-DC-H can be used. Either filter to be ordered separately.

RADIATION PATTERN FOR THE VHF BAND (156 - 162.5 MHz):

TYPICAL RADIATION PATTERN (E-PLANE)

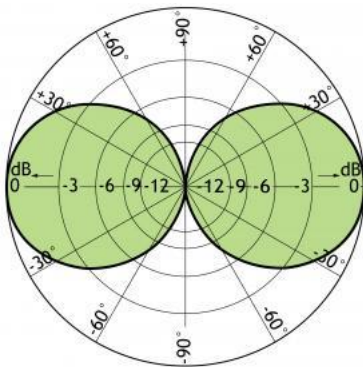

TYPICAL RADIATION PATTERN (H-PLANE)

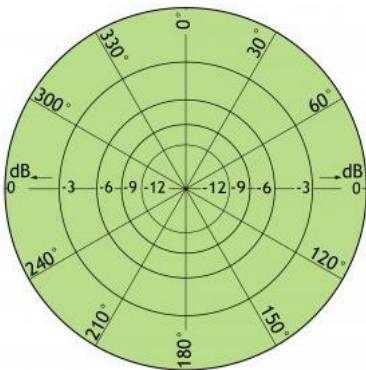

**TYPICAL GAIN AND SWR CURVES:
FOR THE VHF BAND (156 - 162.5 MHz)**

SWR

Gain

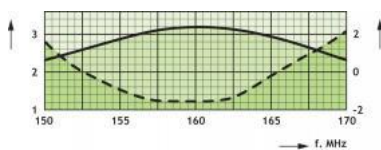

VERTICAL RADIATION PATTERN

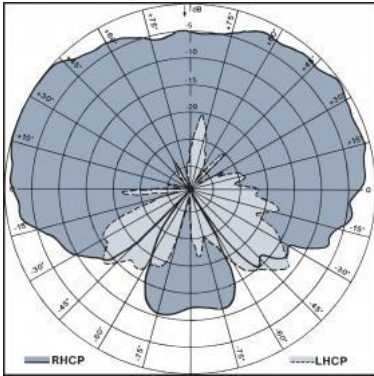

TYPICAL RESPONSE CURVES AND RADIATION PATTERN FOR THE GPS-PART (1575 MHz):

GAIN AND NOISE FIGURE (dB)

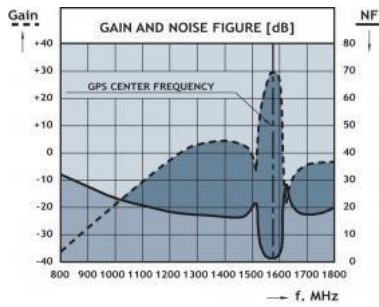

GAIN AND NOISE FIGURE AROUND GPS CENTER FREQUENCY (dB)

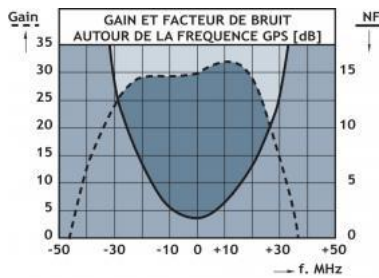

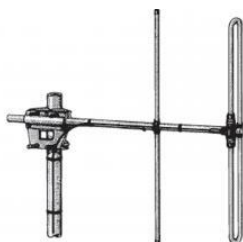

R 2-3/..., R 2-6/...

Directional Antennas with 3 and 6 dBd Gain for the 160 MHz Band

- These antennas are 2- and 3-element Yagi antennas with 3 and 6 dBd gain, respectively.
- When mounted for vertical polarization, the horizontal coverage is R 2-3: 150° and R 2-6: 120°. R 2-3/... and R 2-6/... cover the 160 MHz band in two models.
- These Yagis incorporate baluns optimized for wide bandwidth and accurate matching.

DESCRIPTION

- The entire balun unit and feeder cable inlet are completely sealed in a polythene moulding ensuring permanent waterproof connections. The antennas are supplied with a 3 m "tail" of RG 213 terminated with an N-female connector.
- Radiating elements, supporting booms and adjoining metal castings have been constructed in high-quality aluminium alloys to prevent corrosion. All metal parts are DC-grounded.
- The antennas are designed for back mounting and are provided with rear extended booms.
- These antennas can be stacked and fed in phase with a matching harness for increased gain.
- A mast clamp for fixation on 30 - 58 mm diameter mast tube is supplied.

ORDERING DESIGNATIONS

TYPE	PRODUCT NO.	FREQUENCY
2-element Yagi 3 dBd		
R 2-3/l	Replaced by S.2Y	144 - 162 MHz
R 2-3/h		156 - 175 MHz
3-element Yagi 6 dBd		
R 2-6/l	Replaced by S.3Y	144 - 162 MHz
R 2-6/h		156 - 175 MHz

SPECIFICATIONS

ELECTRICAL		
MODEL	R 2-3/...	R 2-6/...
ANTENNA TYPE	2-element Yagi	3-element Yagi
FREQUENCY	"l": 144 - 162 MHz "h": 156 - 175 MHz	"l": 144 - 162 MHz "h": 156 - 175 MHz
IMPEDANCE	Nom. 50 Ω	
POLARIZATION	Vertical or horizontal	
GAIN	5 dBi 3 dBd	8 dBi 6 dBd
FRONT TO BACK RATIO	12 dBd	16 dBd
HALF-POWER BEAMWIDTH	E-plane: 75° H-plane: 150°	E-plane: 70° H-plane: 120°

BANDWIDTH	19 MHz	
SWR	≤ 1.5	
MAX. POWER	150 W	
ANTISTATIC PROTECTION	All metal parts DC-grounded (Connector shows a DC-short)	
MECHANICAL		
TEMP. RANGE	-25°C → +60°C	
CONNECTION	3 m tail of RG 213 terminated with N-female connector	
WIND SURFACE	0.0828 m ²	0.0936 m ²
WIND LOAD	105 N @ 160 km/h	118 N @ 160 km/h
COLOUR	"Aluminium"	
MATERIALS	Elements/Boom/Saddle clamps: Aluminium alloys. Fittings: Stainless steel	
BOOM LENGTH	Approx. 0.93 m	Approx. 1.2 m
BOOM DIA.	31.8 mm	
MAX. ELEMENT LENGTH	Approx. 1.1 m	
DIA. OF ELEMENTS	19 mm	
WEIGHT	Approx. 3.5 kg	Approx. 4.1 kg
MOUNTING	Supplied with mast bracket suiting 30 - 58 mm dia. mast tube	

TYPICAL RADIATION PATTERN (E-PLANE)

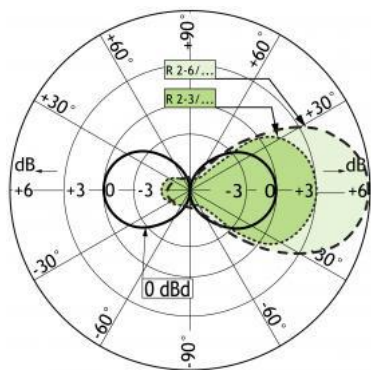

If the antennas are mounted for vertical polarization, these curves show the radiation patterns in the vertical plane.

TYPICAL RADIATION PATTERN (H-PLANE)



If the antennas are mounted for vertical polarization, these curves show the radiation patterns in the horizontal plane (horizontal coverage).



R 2-8/..., R 2-10/...

Directional Antennas with 8 and 10 dBd Gain for the 160 MHz Band

- These antennas are 6- and 8-element Yagi antennas with 8 and 10 dBd gain, respectively.

DESCRIPTION

- When mounted for vertical polarisation the horizontal coverage is R 2-8: 64° and R 2-10: 50°. R 2-8/... and R 2-10/... cover the 160 MHz band in two models.
- These Yagis incorporate baluns optimized for wide bandwidth and accurate matching.
- The entire balun unit and feeder cable inlet are completely sealed in a polythene moulding ensuring permanent waterproof connections. The antennas are supplied with a 3 m "tail" of RG 213 terminated with an N-female connector.
- Radiating elements, supporting booms and adjoining metal castings have been constructed in high quality aluminium alloys to prevent corrosion. All metal parts are DC-grounded.
- The antennas are designed for back mounting and are provided with rear extended booms.
- These antennas can be stacked and fed in phase with a matching harness for increased gain.
- A mast clamp for fixation on 30 - 58 mm diameter mast tube is enclosed.

R 2-10/...



ORDERING DESIGNATIONS

TYPE	PRODUCT NO.	FREQUENCY
6-element Yagi 8 dBd		
R 2-8/l	Replaced by S.6Y	140 - 155 MHz
R 2-8/h		155 - 175 MHz
8-element Yagi 10 dBd		
R 2-10/l	Replaced by S.8Y	145 - 165 MHz
R 2-10/h		155 - 175 MHz

SPECIFICATIONS

ELECTRICAL		
MODEL	R 2-8/...	R 2-10/...
ANTENNA TYPE	6-element Yagi	8-element Yagi
FREQUENCY	"l": 140 - 155 MHz "h": 155 - 175 MHz	"l": 145 - 165 MHz "h": 155 - 175 MHz
IMPEDANCE	Nom. 50 Ω	
POLARIZATION	Vertical or horizontal	

GAIN	10 dBi 8 dBd	12 dBi 10 dBd
FRONT TO BACK RATIO	16 dBd	20 dBd
HALF-POWER BEAMWIDTH	E-plane: 56° H-plane: 64°	E-plane: 40° H-plane: 50°
BANDWIDTH	20 MHz	
SWR	≤ 1.5	
MAX. POWER	150 W	
ANTISTATIC PROTECTION	All metal parts DC-grounded (Connector shows a DC-short)	
MECHANICAL		
MODEL	R 2-8/...	R 2-10/...
TEMP. RANGE	-25°C → +60°C	
CONNECTION	3 m tail of RG 213 terminated with type "N" female connector	
WIND SURFACE	0.139 m ²	0.15 m ²
WIND LOAD	176 N @ 160 km/h	190 N @ 160 km/h
COLOUR	"Aluminium"	
MATERIALS	Elements/Boom/Saddle clamps: Aluminium alloys. Fittings: Stainless steel	
BOOM LENGTH	Approx. 2.7 m	Approx. 3.4 m
BOOM DIA.	31.8 mm	
MAX. ELEMENT LENGTH	Approx. 1.06 m	
DIA. OF ELEMENTS	19 mm	
WEIGHT	Approx. 4.8 kg	Approx. 5.2 kg
MOUNTING	Supplied with mast bracket suiting 30 - 58 mm dia. mast tube	

TYPICAL RADIATION PATTERN (E-PLANE)



If the antennas are mounted for vertical polarisation these curves show the radiation patterns in the vertical plane.

TYPICAL RADIATION PATTERN (H-PLANE)

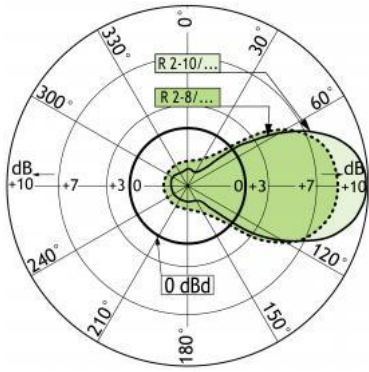

If the antennas are mounted for vertical polarisation these curves show the radiation patterns in the horizontal plane (horizontal coverage).

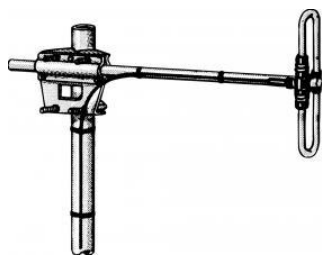

DP 70/...

Centre-Fed Folded Dipole for the 450 MHz Band

- Single, 0 dBd folded dipole incorporating a balun optimized for wide bandwidth and accurate matching.
- The entire balun unit and feeder terminations are completely sealed in a polythene moulding ensuring permanent waterproof connections.

DESCRIPTION

- The dipole element, the supporting boom and the adjoining metal castings have been constructed in high quality aluminium alloys to prevent corrosion. All metal parts are DC-grounded.
- DP 70/... may be arranged in a variety of ways to produce higher gain, directional lobes or interference cancellation, and suitable matching harnesses are available.
- The antenna is supplied complete with clamp for mounting on 30 - 58 mm diameter mast tube.

ORDERING DESIGNATIONS

TYPE	PRODUCT NO.	FREQUENCY
DP 70/l	Replaced by S.1	380 - 430 MHz
DP 70/h		420 - 470 MHz

SPECIFICATIONS

ELECTRICAL	
MODEL	DP 70/...
ANTENNA TYPE	Centre-fed folded dipole with boom
FREQUENCY	DP 70/l : 380 - 430 MHz DP 70/h: 420 - 470 MHz
IMPEDANCE	Nom. 50 Ω
POLARIZATION	Vertical or horizontal
GAIN	2 dBi 0 dBd
BANDWIDTH	50 MHz
SWR	≤ 1.5
MAX. POWER	150 W
MECHANICAL	
TEMP. RANGE	-25°C → +60°C
CONNECTOR	3 m tail of RG 213 terminated with type N-female conn.
WIND SURFACE	0.0396 m ²
WIND LOAD	12 N @ 160 km/h
COLOUR	"Aluminium"

MATERIALS	Aluminium
DIMENSIONS	Boom dia. : 31.8 mm Dipole element dia. : 19.0 mm Boom length : Approx. 0.9 m Element length : Approx. 0.3 m
WEIGHT	Approx. 2.6 kg
MOUNTING	On 30 - 58 mm dia. mast tube

TYPICAL GAIN AND SWR CURVES

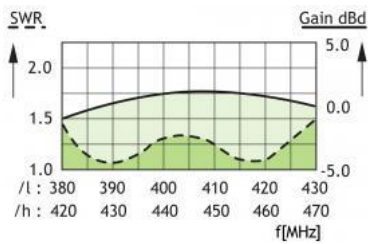

TYPICAL RADIATION PATTERN (E-PLANE)



If the antenna is mounted for vertical polarisation this curve shows the radiation pattern in the vertical plane.

TYPICAL RADIATION PATTERN (H-PLANE)



If the antenna is mounted for vertical polarisation this curve shows the radiation pattern in the horizontal plane (horizontal coverage). The assymetry is caused by the presence of the mast.



R 70-3/..., R 70-7/..., R 70-10/...

Directional Antennas with 3, 7 and 10 dBd Gain for the 450 MHz Band

- These antennas are 2-, 4- and 8-element Yagi antennas with 3, 7, and 10 dBd gain, respectively.

DESCRIPTION

- When mounted for vertical polarization, the horizontal coverage is R 70-3: 150°, R 70-7: 90° and R 70-10: 58°.
- These Yagis incorporate baluns optimized for wide bandwidth and accurate matching.
- The entire balun unit and feeder cable inlet are completely sealed in a polythene moulding ensuring permanent waterproof connections. The antennas are supplied with a 3 m "tail" of RG 213 terminated with an N-female connector.
- Radiating elements, supporting booms and adjoining metal castings have been constructed in high-quality aluminium alloys to prevent corrosion. All metal parts are DC-grounded.
- The antennas are designed for back mounting and are provided with rear extended booms.
- These antennas can be stacked and fed in phase with a matching harness for increased gain.
- A mast clamp for fixation on 30 - 58 mm diameter mast tube is supplied.

ORDERING DESIGNATIONS

TYPE	PRODUCT NO.	ANTENNA TYPE	FREQUENCY
R 70-3/s	Replaced by S.2Y	2-element Yagi 3 dBd	380 - 420 MHz
R 70-3/l		2-element Yagi 3 dBd	390 - 430 MHz
R 70-3/h		2-element Yagi 3 dBd	420 - 470 MHz
R 70-7/l	Replaced by S.4Y	4-element Yagi 7 dBd	380 - 430 MHz
R 70-7/h		4-element Yagi 7 dBd	420 - 470 MHz
R 70-10/l	Replaced by S.8Y	8-element Yagi 10 dBd	380 - 430 MHz
R 70-10/h		8-element Yagi 10 dBd	420 - 470 MHz

SPECIFICATIONS

ELECTRICAL				
MODEL	R 70-3/...	R 70-7/...	R 70-10/...	
ANTENNA TYPE	2-element Yagi	4-element Yagi	8-element Yagi	
FREQUENCY	s: 380-420MHz l: 390-430MHz h: 420-470MHz	l: 380-430MHz h: 420-470MHz	l: 380-430MHz h: 420-470MHz	
IMPEDANCE	50 Ω			

POLARIZATION	Vertical or horizontal		
GAIN	5 dBi 3 dBd	9 dBi 7 dBd	12 dBi 10 dBd
FRONT TO BACK RATIO	12 dB	15 dB	15.1 dB Typ. better than 19 dB
HALF POWER BEAMWIDTH	E-plane: 75° H-plane: 150°	E-plane: 60° H-plane: 90°	E-plane: 51° H-plane: 58°
BANDWIDTH	40 - 50 MHz		
SWR	≤ 1.5		
MAX. POWER	150 W		
ANTISTATIC PROTECTION	All metal parts DC-grounded (Connector shows a DC-short)		
MECHANICAL			
TEMP. RANGE	-25° C → +60° C		
CONNECTION	3 m tail of RG 213 terminated with N-female connector		
WIND SURFACE	0.046 m ²	0.061 m ²	0.080 m ²
WIND LOAD	50 N @ 160 km/h	80 N @ 160 km/h	102 N @ 160 km/h
COLOUR	"Aluminium"		
MATERIALS	Elements/Boom/Saddle clamps: Aluminium alloys. Fittings: Stainless steel. Bracket: Hot-dipped galvanized steel		
BOOM LENGTH	Approx. 0.65 m	Approx. 0.9 m	Approx. 1.4 m
BOOM DIA.	31.8 mm		
MAX. ELEMENT LENGTH	0.43 m		
DIA. OF ELEMENTS	13 mm		
WEIGHT	Approx. 3.1 kg	Approx. 3.4 kg	Approx. 3.7 kg
MOUNTING	Supplied with mast bracket suiting 30 - 58 mm dia. mast tube		

TYPICAL RADIATION PATTERN (E-PLANE)

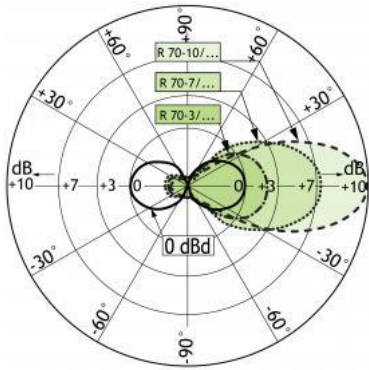

If the antennas are mounted for vertical polarization, these curves show the radiation patterns in the vertical plane.

TYPICAL RADIATION PATTERN (H-PLANE)



If the antennas are mounted for vertical polarization, these curves show the radiation patterns in the horizontal plane (horizontal coverage).

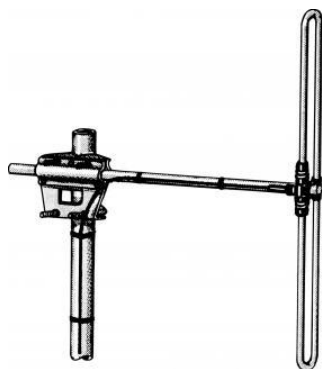

DP 4/...

Centre-Fed Folded Dipole for the 80 MHz Band

- Single, 0 dBd folded dipole incorporating a balun optimized for wide bandwidth and accurate matching.

DESCRIPTION

- The entire balun unit and feeder terminations are completely sealed in a polythene moulding ensuring permanent waterproof connections.
- The dipole element, the supporting boom and the adjoining metal castings have been constructed in high quality aluminium alloys to prevent corrosion. All metal parts are DC-grounded.
- These antennas may be arranged in a variety of ways to produce higher gain, directional lobes or interference cancellation, and suitable matching harnesses are available.
- The antenna is supplied complete with clamp for mounting on 30 - 58 mm diameter mast tubes.

ORDERING DESIGNATIONS

TYPE	PRODUCT NO.	FREQUENCY
DP 4/l	Replaced by S.1	66 - 77 MHz
DP 4/h		75 - 88 MHz

SPECIFICATIONS

ELECTRICAL	
MODEL	DP 4/...
ANTENNA TYPE	Folded dipole
FREQUENCY	DP 4/l : 66 - 77 MHz DP 4/h : 75 - 88 MHz
IMPEDANCE	Nom. 50 Ω
RADIATION	Omnidirectional
POLARIZATION	Vertical or horizontal
GAIN	2 dBi 0 dBd
BANDWIDTH	11 - 13 MHz
SWR	≤ 1.5
MAX. POWER	150 W
ANTISTATIC PROTECTION	All metal parts DC-grounded (Connector shows a DC-short)
MECHANICAL	

TEMP. RANGE	-25°C → +60°C
CONNECTOR	3 m tail of RG 213 terminated with type N-female connector
WIND SURFACE	0.12 m ²
WIND LOAD	152 N @ 160 km/h
COLOUR	“Aluminium”
MATERIALS	Aluminium and environmentproof plastics
DIMENSIONS	Dipole element dia: 19 mm Boom dia. : 31.8 mm Boom length : Approx. 1.4 m Element length : Approx. 1.8 m
WEIGHT	Approx. 4.0 kg
MOUNTING	On 30 - 58 mm dia. mast tube

TYPICAL GAIN AND SWR CURVES

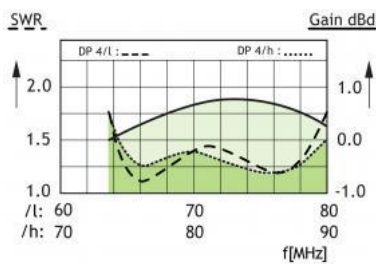

TYPICAL RADIATION PATTERN (E-PLANE)



TYPICAL RADIATION PATTERN (H-PLANE)







CXL 150-1LW-SS-R/...

Universal, Unity-Gain Base Station and Marine Antenna for the 160 MHz Band

- This multi-purpose, omnidirectional, 0 dBd, rod-type base station and marine antenna covers the 160 MHz band in three models with 10 MHz overlap and can be used in a wide variety of applications.
- The antenna mount is made from a High Strength low Carbon Steel Alloy.

DESCRIPTION

- The broad-banded $\frac{1}{2} \lambda$ dipole antenna element is sealed in a high-quality conical glass fibre tube with low wind-load, which will ensure undisturbed performance by corrosive environments.
- The new LW-SS Mount is made from a High Strength low Carbon Steel Alloy well suited for extreme marine environments due to its superior resistance to corrosion.
- The accompanying U-bolts and fittings are made of stainless steel.
- To be mounted on vertical or horizontal mast tubes, 16 to 54 mm in outer diameter.
- The cable can be led either on the outside or along the inside of the mast tube.
- Large bandwidth with respect to both SWR and gain.
- CXL 150-1LW-SS-R/... is DC-grounded to substantially reduce noise caused by atmospherical discharges and consequently shows a DC-short across the coaxial cable.
- The CXL 150-1LW-SS-R/... is a vibration-proof, lightweight, slim-line, corrosion-resistant, modern style base station and marine antenna.

ORDERING DESIGNATIONS

TYPE	FREQUENCY	PRODUCT NO.
CXL 150-1LW-SS-R/s	138 - 156 MHz	110000374
CXL 150-1LW-SS-R/l	146 - 165 MHz	110000375
CXL 150-1LW-SS-R/h	155 - 175 MHz	110000376

SPECIFICATIONS

ELECTRICAL	
MODEL	CXL 150-1LW-SS-R/...
ANTENNA TYPE	$\frac{1}{2} \lambda$ coaxial dipol, broad-banded
FREQUENCY	CXL 150-1LW-SS-R/s: 138 - 156 MHz CXL 150-1LW-SS-R/l: 146 - 165 MHz CXL 150-1LW-SS-R/h: 155 - 175 MHz
IMPEDANCE	Nom. 50 Ω
RADIATION	Omnidirectional
POLARIZATION	Vertical
GAIN	2 dBi 0 dBd
BANDWIDTH	18 - 21 MHz depending on model

SWR	CXL 150-1LW-SS-R/s :	138 - 156 MHz \leq 1.5
	CXL 150-1LW-SS-R/l:	146 - 163 MHz \leq 1.5 146-165 MHz \leq 1.75
	CXL 150-1LW-SS-R/h:	156 - 174 MHz \leq 1.5 155 - 175 MHz \leq 1.75
MAX. POWER	150 W	
ANTISTATIC PROTECTION	All metal parts DC-grounded (Connector shows a DC-short)	
MECHANICAL		
TEMP. RANGE	-30° C \rightarrow +70° C	
CONNECTOR	N-female	
WIND SURFACE	0.022 m ² / 0.24 ft ²	
WIND LOAD	32 N @ 160 km/h / 99.42 mph.	
MAX. WIND SPEED	Tested to 200 km/h / 124.27 mph.	
INGRESS PROTECTION LEVEL	IP 66	
COLOUR	Marine white	
MATERIALS	Radome: Polyurethane-coated glass fibre Mounting bracket: Stainless acid-proof steel U-bolt and fittings: Stainless steel	
TOTAL HEIGHT	Approx. 1.3 m / 51.18 in. (Dep. on frequency)	
DIA. IN TOP END	17 mm / 0.67 in.	
DIA. IN BOTTOM END	23 mm / 0.91 in.	
WEIGHT	Approx. 1.0 kg / 2.20 lb.	
MOUNTING	On 16 to 54 mm / 0.63 x 2.13 in.dia. mast tube	

TYPICAL GAIN AND SWR CURVES

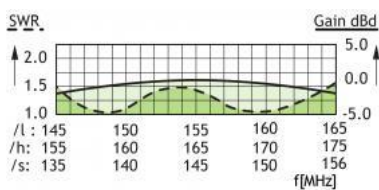

TYPICAL RADIATION PATTERN (E-PLANE)

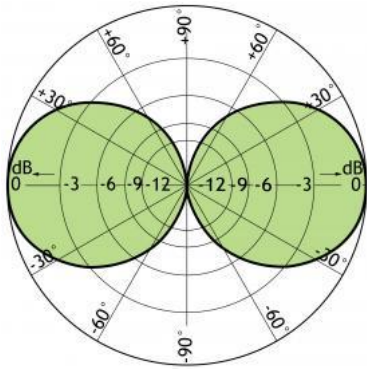

TYPICAL RADIATION PATTERN (H-PLANE)

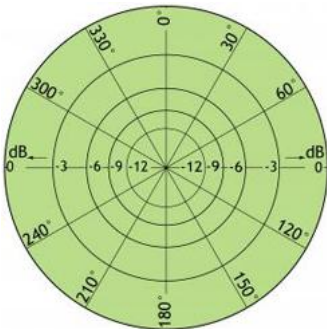

MULTI-PURPOSE MOUNTING BRACKET

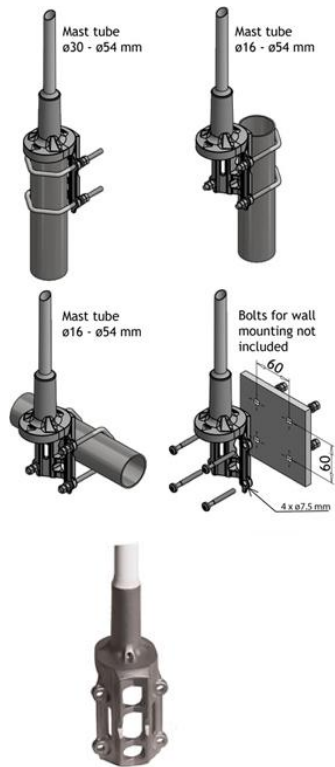

PLEASE NOTE

The antenna is delivered with a DC-connection between the antenna element and the mounting bracket.



S.M4

Four element stacked dipole array

- The S.M4 are an array of four dipoles mounted on an aluminium mast.
- Each folded dipole balun assembly and harness junction is completely encapsulated in epoxy resin, totally preventing moisture ingress.
- The balun assembly has been tested to BS5490:IP67.

Description

- The S.M4 offset array is used extensively in UHF and VHF Trunking systems.
- The dipoles can be easily oriented on site or before shipment to adjust between omnidirectional and directional patterns, and beam tilt is easily achieved via the parallel feed.
- The VHF antenna disassembles to reduce shipping costs, and the boom can be supplied in two parts if requested.

ORDERING DESIGNATIONS

TYPE	FREQUENCY	PRODUCT NO.
S.M4-127-SB	117 - 137 MHz	123003120
S.M4-165-SB	155 - 175 MHz	123003121
S.M4-184-SB	176 - 192 MHz	123003122
S.M4-200-SB	192 - 208 MHz	123003123
S.M4-405	380 - 430 MHz	123003124
S.M4-445	420 - 470 MHz	123003125

SB = SPLIT BOOM

Specifications

TYPE	PRODUCT NO.
UA66-22	123001005
2140.01.00.00	123001012
2141.01.00.00	123001013
ELECTRIAL	
FREQUENCY RANGE	117 - 470 MHz
INPUT IMPEDANCE	50Ω
BANDWIDTH	± 5.5% of centre frequency
SWR	<1.5:1
FRONT TO BACK RATIO	7 dB

MAXIMUM INPUT POWER	250 Watts
POLARISATION	Vertical
FORWARD GAIN	Omni 5.7 dBd Offset 8.7 dBd
3 dB BEAMWIDTH	E Plane 21° H Plane 180° (Offset)
MECHANICAL	
STANDARD CONNECTION	3 m (118.11 in.) Length of RG 213 c/w 'N' type socket
ELEMENTS	12.7 mm dia. x 1.6 mm wall aluminium alloy grade 6063T6
SUPPORT BOOM UHF	UHF 38.1 mm dia. x 3.2 mm wall aluminium alloy grade 6082T6
SUPPORT BOOM VHF	VHF 63.5 mm dia. x 6.3 mm wall aluminium alloy grade 6082T6
FASTENERS	Stainless steel grade A2-70
DIPOLE CLAMPS	Cast aluminium alloy
DIPOLE ADJUSTMENT	M8 stainless steel screws
SADDLE CLAMPS	Diecast zinc alloy
INSULATOR	Epoxy resin encapsulant
LIGHTNING PROTECTION	Direct grounded VHF lightning finial
MOUNTING BRACKETS UHF	UHF fit inside scaffold pole
MOUNTING BRACKETS VHF	VHF to suit structure
TYPICAL WEIGHT (UHF)	UHF 6 kg (13.23 lb.)
TYPICAL WEIGHT (VHF)	VHF 26 kg (57.32 lb.)
TYPICAL LENGTH (UHF)	UHF 2.5 m (98.43 in.)
TYPICAL LENGTH (VHF)	VHF 6 m (236.22 in.)
TYPICAL WIND LOADING @ 162 km/h (UHF)	UHF 180N
TYPICAL WIND LOADING @ 162 km/h (VHF)	VHF 620N

MOUNTING

Mounting accessories to be ordered separately



UA66-22

Very strong square cast alloy clamp, fits up to 50 mm diameter tubes as either a cross-over or parallel clamp. Supplied with two stainless steel 'U' bolts.



2140.01.00.00

Parallel clamps, in galvanised steel with stainless steel fixings, fits from 25-60 mm diameter tubes.



2141.01.00.00

Parallel clamps, in galvanised steel with stainless steel fixings, fits from 38-120 mm diameter tubes.



TYPICAL RADIATION PATTERN (E-PLANE)

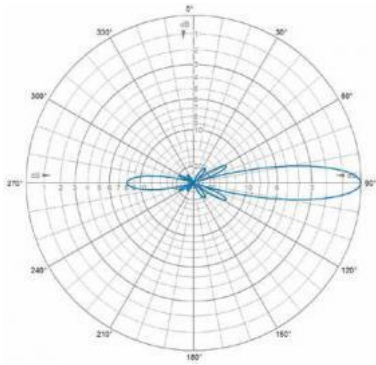

TYPICAL RADIATION PATTERN (H-PLANE)

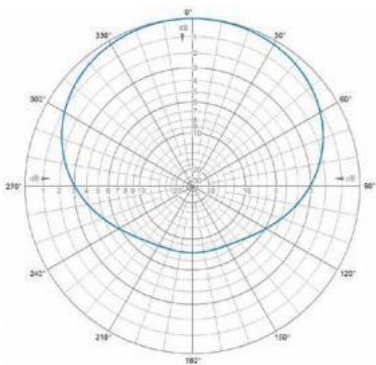



CXL 2000-6/...

6 dBd Omdirectional Base Station and Marine Antenna for the 2000 MHz Band

- Vertically polarized, omnidirectional base station and marine antenna.
- Approximately 6 dBd gain.

DESCRIPTION

- Simple mounting using the 1" revolving nut system.
- Wide variety of accessory mounting brackets available.
- Large bandwidth with respect to both SWR and gain.
- Highly suitable for duplex operation with large spacing between the TX and the RX frequencies.
- The antenna element is sealed in a high-quality glass fibre tube.
- All metal parts in the antenna are DC-grounded to reduce the noise caused by atmospherical discharge. Consequently, the antenna shows a DC-short across the coaxial cable.
- The CXL 2000-6/... is a vibration-proof, lightweight, slim-line, corrosion resistant, modern style base station and marine antenna.

ORDERING DESIGNATIONS

TYPE	PRODUCT NO.	FREQUENCY
CXL 2000-6/l	100000548	1900 - 2050 MHz
CXL 2000-6/m	100000623	2000 - 2150 MHz
CXL 2000-6/h	100000360	2100 - 2200 MHz

SPECIFICATIONS

ELECTRICAL	
MODEL	CXL 2000-6/...
ANTENNA TYPE	Coaxial, collinear antenna, broad-banded
FREQUENCY	Models within 1900 - 2200 MHz
IMPEDANCE	Nom. 50 Ω
POLARIZATION	Vertical
GAIN	8 dBi 6 dBd
BANDWIDTH	150 ≥ MHz @ SWR ≤ 2.0
SWR	≤ 2.0, typ. ≤ 1.5
MAX. POWER	100 W
ANTISTATIC PROTECTION	All metal parts DC-grounded (Connector shows a DC-short)

MECHANICAL	
TEMP. RANGE	-30°C → +70°C
CONNECTOR	N-female
WIND SURFACE	Approx. 0.03 m ²
WIND LOAD	Approx. 42 N @ 160 km/h
COLOUR	Marine white
MATERIALS	Shroud: Polyurethane-coated glass fibre Mounting bracket: Chromed brass
TOTAL HEIGHT	Approx. 1.2 m
DIA. IN TOP END	21 mm
DIA. IN BOTTOM END	23 mm
WEIGHT	Approx. 600 g
MOUNTING	On 1" RG (G1"-11) threaded water pipe or on optional mounting brackets (see below)

ACCESSORIES (to be ordered separately)

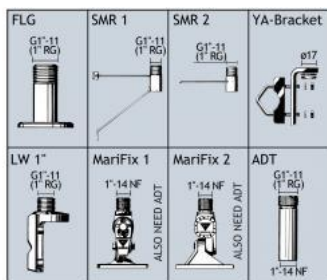

TYPICAL GAIN AND SWR CURVES

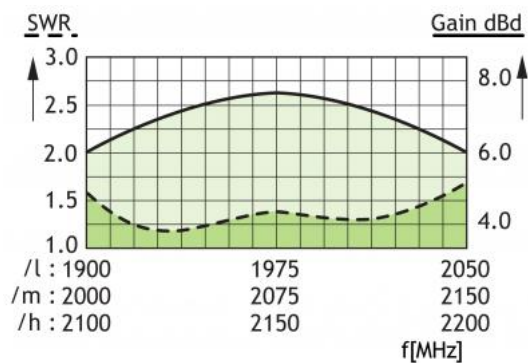

TYPICAL RADIATION PATTERN (E-PLANE)

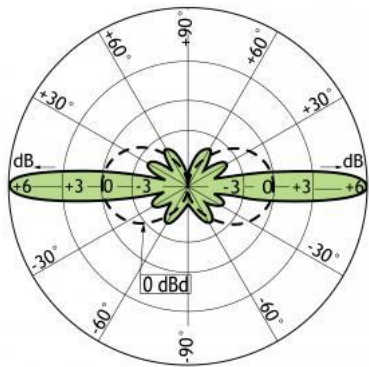

TYPICAL RADIATION PATTERN (H-PLANE),

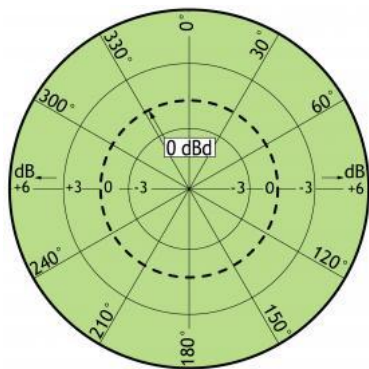



CXL 2000-3

3 dBd Omnidirectional Base Station and Marine Antenna for the 2000 MHz Band

- Vertically polarized, omnidirectional base station and marine antenna.
- Approximately 3 dBd gain.

DESCRIPTION

- Simple mounting using the 1" revolving nut system.
- Wide variety of accessory mounting brackets available.
- Large bandwidth with respect to both SWR and gain.
- Highly suitable for duplex operation with large spacing between the TX and the RX frequencies.
- The antenna element is sealed in a high-quality, conical glass fibre tube.
- All metal parts in the antenna are DC-grounded to reduce the noise caused by atmospherical discharge. Consequently, the antenna shows a DC-short across the coaxial cable.
- The CXL 2000-3/... is a vibration-proof, lightweight, slim-line, corrosion resistant, modern style base station and marine antenna.

ORDERING DESIGNATIONS

TYPE	PRODUCT NO.	FREQUENCY
CXL 2000-3	100000190	1900 - 2200 MHz

SPECIFICATIONS

ELECTRICAL	
MODEL	CXL 2000-3
ANTENNA TYPE	Coaxial, collinear antenna, broad-banded
FREQUENCY	1900 - 2200 MHz
IMPEDANCE	Nom. 50 Ω
POLARIZATION	Vertical
GAIN	5 dBi 3 dBd
BANDWIDTH	≥ 200 MHz @ SWR ≤ 2.0 ≥ 300 MHz @ SWR ≤ 2.5
SWR	≤ 2.5, typ. ≤ 2.0
MAX. POWER	100 W
ANTISTATIC PROTECTION	All metal parts DC-grounded (Connector shows a DC-short)
MECHANICAL	

TEMP. RANGE	-30°C → +70°C
CONNECTOR	N-female
WIND SURFACE	Approx. 0.02 m ²
WIND LOAD	Approx. 25 N @ 160 km/h
COLOUR	Marine white
MATERIALS	Shroud: Polyurethane-coated glass fibre Mounting bracket: Chromed brass
TOTAL HEIGHT	Approx. 700 mm
DIA. IN TOP END	22 mm
DIA. IN BOTTOM END	23 mm
WEIGHT	Approx. 400 g
MOUNTING	On 1" RG (G1"-11) threaded water pipe or on optional mounting brackets (see below)

ACCESSORIES (to be ordered separately)

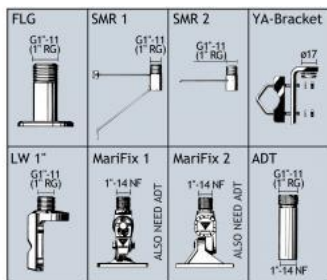

TYPICAL GAIN AND SWR CURVES

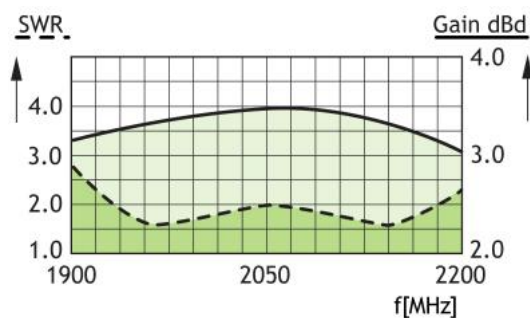

TYPICAL RADIATION PATTERN (E-PLANE)

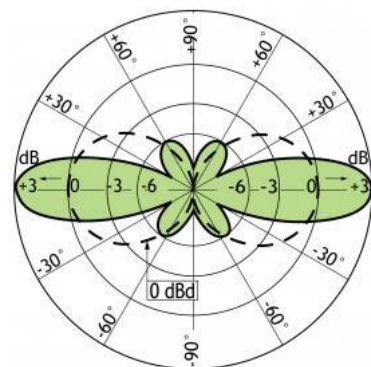

TYPICAL RADIATION PATTERN (H-PLANE)





CXL 2000-8LW/...

8 dBd Omdirectional Base Station and Marine Antenna for the 2000 MHz Band

- Vertically polarized, omnidirectional base station and marine antenna.
- The CXL 2000-8LW/... is a vibration-proof, lightweight, slim-line, corrosion resistant, modern style base station and marine antenna.
- The antenna element is sealed in a high-quality glass fibre tube

DESCRIPTION

- Provided with the sturdy "LW" mast mount - a lightweight, multipurpose, epoxy-coated mounting bracket made of non-corrosive aluminium.
- The accompanying U-bolts and fittings are made of stainless steel.
- To be mounted on vertical or horizontal mast tubes, 16 to 54 mm in outer diameter.
- The cable can be led either on the outside or along the inside of the mast tube.
- Large bandwidth with respect to both SWR and gain.
- Highly suitable for duplex operation with large spacing between the TX and the RX frequencies.
- All metal parts in the antenna are DC-grounded to reduce the noise caused by atmospherical discharge. Consequently, the antenna shows a DC-short across the coaxial cable.

ORDERING DESIGNATIONS

TYPE	PRODUCT NO.	FREQUENCY
CXL 2000-8LW/m	100000634	2025 - 2105 MHz

SPECIFICATIONS

ELECTRICAL	
MODEL	CXL 2000-8LW/...
ANTENNA TYPE	Coaxial, collinear antenna, broadbanded
FREQUENCY	2025 - 2105 MHz
IMPEDANCE	Nom. 50 Ω
POLARIZATION	Vertical
GAIN	10 dBi 8 dBd
HALF POWER BEAMWIDTH	6°
BANDWIDTH	≥ 80 MHz @ SWR ≤ 2.0
SWR	≤ 2.0
MAX. POWER	100 W
ANTISTATIC PROTECTION	All metal parts DC-grounded (Connector shows a DC-short)

MECHANICAL	
TEMP. RANGE	-30°C → +70°C
CONNECTOR	N-female
WIND SURFACE	Approx. 0.037 m ²
WIND LOAD	Approx. 53 N @ 160 km/h
MAX WIND SPEED	200km/h/124.27 mph
INGRESS PROTECTION LEVEL	IP66
COLOUR	Marine white (Ral 9010)
MATERIALS	Shroud: Polyurethane-coated glass fiber Mounting bracket: Seawater resistant aluminium, epoxy-coated Clamps: Stainless steel
TOTAL HEIGHT	Approx. 1.3 m
DIA. IN TOP END	23 mm
DIA. IN BOTTOM END	23 mm
WEIGHT	Approx. 800 g
MOUNTING	On 16 to 54 mm dia. mast tube

TYPICAL GAIN AND SWR CURVES

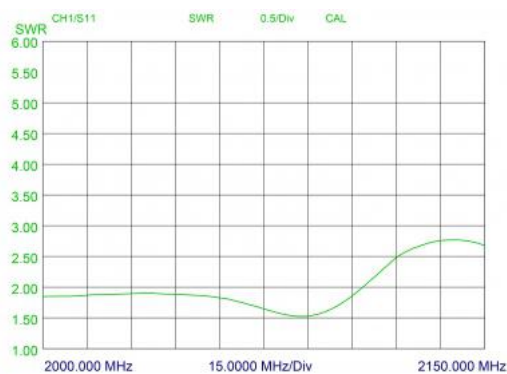

TYPICAL RADIATION PATTERN (E-PLANE)

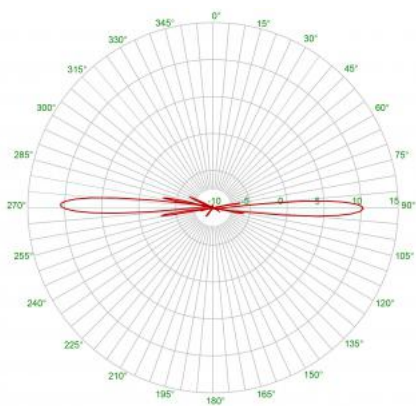

MULTI-PURPOSE MOUNTING BRACKET

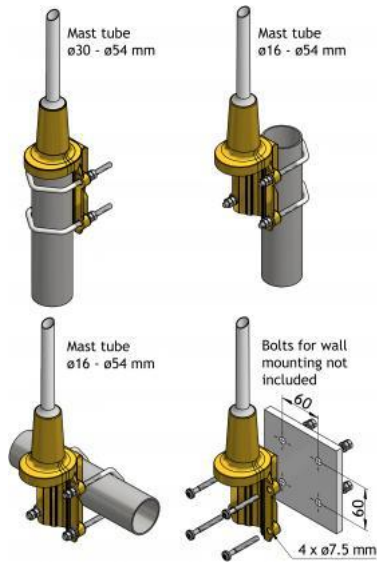

PLEASE NOTE

The antenna is delivered with a DC-connection between the antenna element and the mounting bracket.



CXL 1090-1

Unity Gain Base Station & Marine 1090 MHz Antenna

- The CXL 1090-1 is a 0 dBd, vertically polarized, omnidirectional rod-type base station and marine antenna covering the 1090 MHz band.
- The 1" revolving nut mounting system is standard throughout the base station and maritime sector. Several different mounting brackets are available, making it possible to install the antenna either on the masthead using FLG or SMR 2, side mounted on the mast (using SMR 1) or mounted on a cross-beam (using FLG). Also, the antenna can also be mounted on deck or rooftop by means of the FLG.

DESCRIPTION

- Especially designed for ADS-B aerial surveillance.
- The higher the antenna is mounted, the better coverage. Avoid mounting the antenna parallel with or in the neighbourhood of other metal parts, such as masts, supporting wires etc., as the SWR and the radiation pattern may otherwise be strongly influenced.
- To substantially reduce noise caused by atmospherical discharges, all metal parts in the antenna are DC-grounded. Consequently, the antenna shows a DC-short across the coaxial cable.
- A conical glass fibre tube completely encloses the carefully designed radiating element to ensure long dependable service in all climates.

ORDERING DESIGNATIONS

TYPE	PRODUCT NO.	FREQUENCY
CXL 1090-1	110000386	1050 - 1130 MHz

SPECIFICATIONS

ELECTRICAL	
MODEL	CXL 1090-1
ANTENNA TYPE	½ λ coaxial dipole, broad-banded
FREQUENCY	1050 - 1130 MHz
IMPEDANCE	Nom. 50 Ω
RADIATION	Omnidirectional
POLARIZATION	Vertical
GAIN	2 dBi 0 dBd
HALF POWER BEAMWIDTH	80°
BANDWIDTH	80 MHz
SWR	≤ 1.5
MAX. POWER	100 W
MECHANICAL	
TEMP. RANGE	-30°C to +70°C

CONNECTOR	N-female
WIND SURFACE	Approx. 0.0070 m ²
WIND LOAD	Approx. 9 N @ 160 km/h
MAX. WIND SPEED	200 km/h (124.27 mph)
INGRESS PROTECTION LEVEL	IP66
COLOUR	Marine white (RAL 9010)
MATERIALS	Shroud: Polyurethane-coated glass fibre Mounting bracket: Chromed brass
TOTAL HEIGHT	Approx. 420 mm
DIA. IN TOP END	12 mm
DIA. IN BOTTOM END	16 mm
WEIGHT	Approx. 350 g
MOUNTING	On 1" RG (G1"-11) threaded water pipe or on optional mounting brackets (see below)

ACCESSORIES (to be ordered separately)

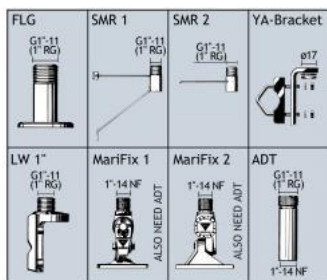



CXL 1090-1LW

Universal, 0 dBd Base Station and Marine Antenna for the 1090 MHz Band

- CXL 1090-1LW is a 0 dBd, vertically polarized, omnidirectional base station and marine antenna, which covers the 1090 MHz band.
- Provided with the sturdy "LW" mast mount - a lightweight, multipurpose, epoxy-coated mounting bracket made of non-corrosive aluminium.

Description

- Especially designed for ADS-B aerial surveillance.
- The accompanying U-bolts and fittings are made of stainless steel.
- To be mounted on vertical or horizontal mast tubes, 16 to 54 mm in outer diameter.
- The cable can be led either on the outside or along the inside of the mast tube.
- Large bandwidth with respect to both SWR and gain.
- The carefully designed, broad-banded antenna element is sealed in a high-quality, conical glass fibre tube with low wind-load, which will ensure performance undisturbed by corrosive environments.
- To substantially reduce noise caused by atmospherical discharges, all metal parts in the antenna are DC-grounded. Consequently, the antenna shows a DC-short across the coaxial cable.
- The CXL 1090-1LW is a vibration-proof, lightweight, slim-line, corrosion resistant, modern style base station and marine antenna.

ORDERING DESIGNATIONS

TYPE	FREQUENCY	PRODUCT NO.
CXL 1090-1LW	1050 - 1130 MHz	100000637

SPECIFICATIONS

ELECTRICAL	
MODEL	CXL 1090-1LW
ANTENNA TYPE	$\frac{1}{2} \lambda$ coaxial dipole, broad-banded
FREQUENCY	1050 - 1130 MHz
IMPEDANCE	Nom. 50 Ω
RADIATION	Omnidirectional
POLARIZATION	Vertical
GAIN	2 dBi 0 dBd
HALF POWER BEAMWIDTH	80°
BANDWIDTH	80 MHz
SWR	< 1.5
MAX. POWER	100 W
ANTISTATIC PROTECTION	All metal parts DC-grounded

	(Connector shows a DC-short)
MECHANICAL	
TEMP. RANGE	-30°C to +70°C
CONNECTOR	N-female
WIND SURFACE	Approx. 0.018 m ²
WIND LOAD	23 N @ 160 km/h
MAX. WINDSPEED	200 km/h (124.27 mph)
INGRESS PROTECTION LEVEL	IP66
COLOUR	Marine white (RAL 9010)
MATERIALS	Shroud: Polyurethane-coated glass fibre Mounting bracket: Seawater resistant aluminium, epoxy-coated Clamps: Stainless steel
TOTAL HEIGHT	Approx. 490 mm
DIA. IN TOP END	13 mm
DIA. IN BOTTOM END	16 mm
WEIGHT	Approx. 560 g
MOUNTING	On 16 to 54 mm dia. mast tube

MULTI-PURPOSE MOUNTING BRACKET

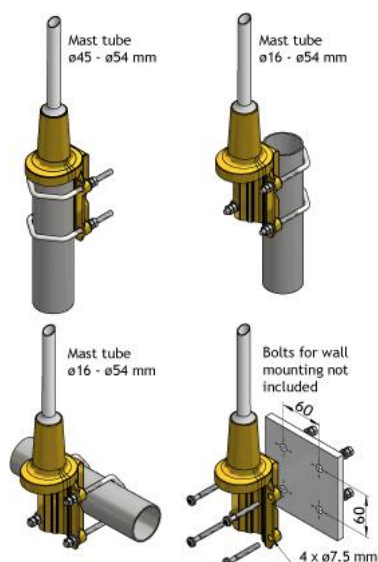

PLEASE NOTE

The antenna is delivered with a DC-connection between the antenna element and the mounting bracket.



GPS/Iridium-FME

Lightweight Circularly Polarized Quadrifilar Helix for Mast Mounting

- Passive quadrifilar helix antenna for fixed installation.
- Covering GPS and Iridium band: 1575 and 1616 - 1626.5 MHz.

DESCRIPTION

- Right-hand circularly polarized antenna (RHCP).
- The circularly polarized antenna minimizes the fading effect often encountered in environments with reflecting obstacles.
- Suitable for mounting on 1" threaded water pipe.
- Comprehensive range of accessory mounting brackets available to make the perfect installation for your specific needs.

ORDERING DESIGNATIONS

TYPE	PRODUCT NO.
GPS/Iridium-FME	112000050

SPECIFICATIONS

ELECTRICAL	
MODEL	GPS/Iridium-FME
ANTENNA TYPE	Passive quadrifilar helix antenna
FREQUENCY	1575 - 1650 MHz
IMPEDANCE	Nom. 50 Ω
POLARIZATION	Circular right-hand
COVERAGE	Hemispherical
GAIN	Approx. 2 dBic 0 dBd
BANDWIDTH	75 MHz
SWR	≤ 2.0
MAX. POWER	2 W
MECHANICAL	
TEMP. RANGE	-30°C → +70°C
CONNECTOR	FME (male)

WIND SURFACE	Approx. 0.0072 m ² / 0.08 feet ²
MAX. WIND SPEED	200 km/h / 124.3 miles/h
WIND LOAD	Approx. 9.6 N @ 150 km/h / 93.2 miles/h
COLOUR	Marine white
MATERIALS	Shroud: Weather resistant low loss plastic
TOTAL HEIGHT	Approx. 23 cm / 9.1 in
ANTENNA DIA.	33 mm / 1.3 in
WEIGHT	Approx. 140 g / 0.31 lb
MOUNTING	On 1" threaded water pipe or on PROCOM 1" mounting brackets (see below)

ACCESSORIES (to be ordered separately)

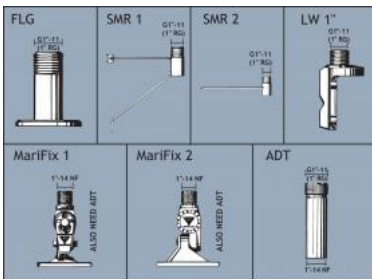

VERTICAL RADIATION PATTERN

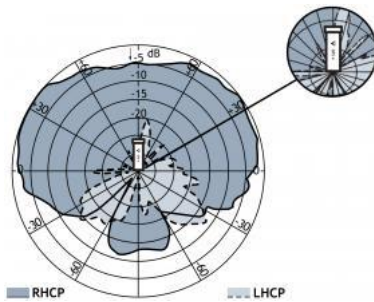

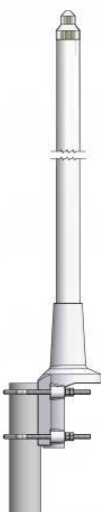

CXL 70-3HD/...-PT

Sturdy, 3 dBd, Omnidirectional lightning protected Base Station Antenna for the TETRA Bands

- CXL 70-3HD/...-PT is 3 dBd, vertically polarized, omnidirectional base station antenna for the TETRA bands with two models.
- The antenna has been approved to withstand lightning (10/350 μ s impulses/200 kA) according to EN 61643-11, VDE 0855-300 and VDE 0185-305-114 in FH-Kiel Laboratory in Germany.

DESCRIPTION

- The antenna is provided with our sturdy type “HD” mast mount - a heavy-duty, multipurpose mounting bracket made of non-corrosive aluminium. The accompanying U-bolts and fittings are made of stainless steel.
- The antenna can be mounted on mast tubes of 58 to 105 mm in outer diameter. Furthermore, the construction of the mount makes it possible to lead the cable either along the inside or on the outside of the mast tube.
- The antenna element is sealed in a high-quality, conical glass fibre tube with low wind load, ensuring undisturbed performance in all climates.
- To substantially reduce noise caused by atmospherical discharges, all metal parts in the antenna are DC-grounded. Consequently, the antenna shows a DC-short across the coaxial cable.
- CXL 70-3HD/...-PT is a vibration-proof, slim-line, corrosion-resistant, modern style base station antenna.

ORDERING DESIGNATIONS

TYPE	PRODUCT NO.	FREQUENCY
CXL 70-3HD/l-PT	100000373	380 - 400 MHz
CXL 70-3HD/h-PT	100000380	410 - 430 MHz

SPECIFICATIONS

ELECTRICAL	
MODEL	CXL 70-3HD/...-PT
ANTENNA TYPE	Medium-gain collinear
FREQUENCY	380 - 400 MHz and 410 - 430 MHz
IMPEDANCE	Nom. 50 Ω
RADIATION	Omnidirectional
POLARIZATION	Vertical
GAIN	5 dBi 3 dBd
HALF POWER BEAMWIDTH	25°

SWR	≤ 1.5
MAX. POWER	250 W
ANTISTATIC PROTECTION	All metal parts DC-grounded (Connector shows a DC-short)
MECHANICAL	
TEMP. RANGE	-30°C → +70°C
CONNECTOR	N-female
WIND SURFACE	0.11 m ²
WIND LOAD	139 N @ 160 km/h
WIND VELOCITY	Tested to 200 km/h
COLOUR	Marine white
MATERIALS	Radome: Polyurethane-coated glass fibre Mounting bracket: Seawater resistant aluminium, polyester-coated
TOTAL HEIGHT	Approx. 1.75 m
WEIGHT	Approx. 4.75 kg
MOUNTING	On 58 - 105 mm dia. mast tube

MULTI-PURPOSE MOUNTING BRACKET

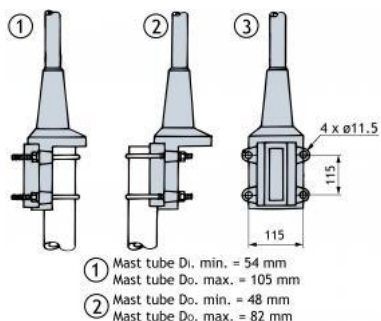

MOUNTING DESCRIPTION FOR GROUND CONNECTION



TYPICAL GAIN AND SWR CURVES

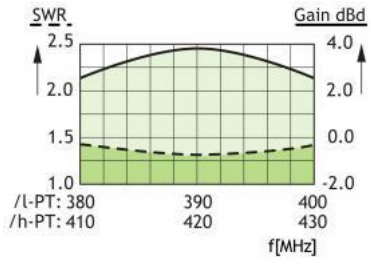

TYPICAL RADIATION PATTERN (E-PLANE)

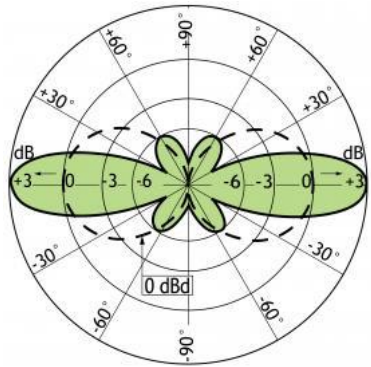

TYPICAL RADIATION PATTERN (H-PLANE)

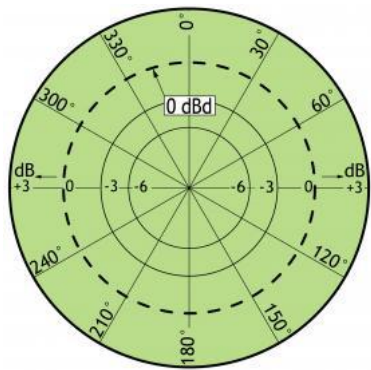



CXL 450-3HD/T-X/...

Sturdy, 3 dBd, Omnidirectional lightning protected Base Station Antenna for 450 MHz Bands

- CXL 450-3HD/T-X/... is a 3 dBd, vertically polarized, omnidirectional base station antenna for 450 MHz bands with three models.
- The antenna has been approved to withstand lightning.

DESCRIPTION

- The antenna is provided with our sturdy type "HD" mast mount - a heavy-duty, multipurpose mounting bracket made of non-corrosive aluminium. The accompanying U-bolts and fittings are made of stainless steel.
- The antenna can be mounted on mast tubes of 58 to 105 mm in outer diameter. Furthermore, the construction of the mount makes it possible to lead the cable either along the inside or on the outside of the mast tube.
- The antenna element is sealed in a high-quality, cylindrical glass fibre tube, ensuring undisturbed performance in all climates.
- To substantially reduce noise caused by atmospherical discharges, all metal parts in the antenna are DC-grounded. Consequently, the antenna shows a DC-short across the coaxial cable.
- CXL 450-3HD/T-X/... is a vibration-proof, slim-line, corrosion-resistant, modern style base station antenna.
- The centre fed dipole design and feed network gives a stable radiation pattern across a wide bandwidth, and allows tilted beam designs to be effectively employed without large pattern distortions.

ORDERING DESIGNATIONS

TYPE	PRODUCT NO.	FREQUENCY	TILT
CXL 450-3HD/T-0/l	100000641	340 - 370 MHz	0°
CXL 450-3HD/T-0/m	100000642	380 - 430 MHz	0°
CXL 450-3HD/T-0/h	100000643	420 - 470 MHz	0°
CXL 450-3HD/T-6/l	100000644	340 - 370 MHz	6°
CXL 450-3HD/T-6/m	100000645	380 - 430 MHz	6°
CXL 450-3HD/T-6/h	100000646	420 - 470 MHz	6°
CXL 450-3HD/T-8/l	100000647	340 - 370 MHz	8°
CXL 450-3HD/T-8/m	100000648	380 - 430 MHz	8°
CXL 450-3HD/T-8/h	100000649	420 - 470 MHz	8°
CXL 450-3HD/T-12/l	100000650	340 - 370 MHz	12°
CXL 450-3HD/T-12/m	100000651	380 - 430 MHz	12°
CXL 450-3HD/T-12/h	100000652	420 - 470 MHz	12°

SPECIFICATIONS

ELECTRICAL	
MODEL	CXL 450-3HD/T-X/...

ANTENNA TYPE	Medium-gain collinear
FREQUENCY	340 - 470 MHz
IMPEDANCE	Nom. 50 Ω
RADIATION	Omnidirectional
POLARIZATION	Vertical
GAIN	5 dBi 3 dBd
HALF POWER BEAMWIDTH	35°
SWR	≤ 1.5
MAX. POWER	300 W
ANTISTATIC PROTECTION	All metal parts DC-grounded (Connector shows a DC-short)
AVAILABLE BEAMTILTS	0, 6, 8 and 12°
PIM	-153 dBc @ 2x43 dBm
MECHANICAL	
TEMP. RANGE	-30°C to +70°C
CONNECTOR	7/16 DIN female
WIND SURFACE	0.09 m ²
WIND LOAD	113 N @ 160 km/h
WIND VELOCITY	Tested to 200 km/h
COLOUR	Marine white
MATERIALS	Radome: Polyurethane-coated glass fibre Mounting bracket: Seawater resistant aluminium, polyester-coated
TOTAL HEIGHT	Approx. 1.74 m, 68.5 Inch
WEIGHT	Approx. 6.35 kg, 14 lb
MOUNTING	On 58 - 105 mm dia. mast tube

MULTI-PURPOSE MOUNTING BRACKET

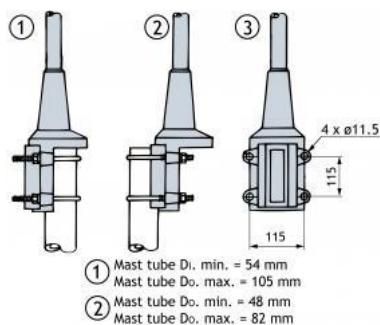

PROCOM A/S



Smedtoften 12, 3600 Frederikssund,
Denmark

